



INSTRUCTIONS

-J03580

REV. 2005-03-29

STYLED CALIPER INSERTS

GENERAL

Kit Number

44917-05, 44991-05, 44918-05, 46573-05, 44919-05, 46576-05, 46578-05, 46580-05, 46582-05, 46584-05

Models

These caliper inserts are designed to fit vehicles that are equipped with kits 44910-05 or 44911-05. See the following table for kit and fitment information.

Table 1. Models

Kits	Fitment
44917-05	Flame design for Left caliper use
44991-05	Flame design for Right caliper use
44918-05	Skull design for Left caliper use
46573-05	Skull design for Right caliper use
44919-05	Buckshot design for Left caliper use
46576-05	Buckshot design for Right caliper use
46578-05	Bar and Shield design for Left caliper use
46580-05	Bar and Shield design for Right caliper use
46582-05	Slotted design for Left caliper use
46584-05	Slotted design for Right caliper use

REMOVAL OF EXISTING INSERT

1. Apply 3M General Purpose Adhesive Remover (Part Number 051135) to edge of adhesive backing visible behind insert. Allow to soak.

NOTE

Avoid excess heat which will damage the chrome surface.

2. Carefully apply heat directly onto insert with a hot air gun.
3. Lift the insert from the caliper surface (1).

NOTE

Dental floss or fishing line can be used to gently saw the heated insert free of the caliper surface.

4. Lift the insert from the caliper surface (1).
5. Remove the remaining adhesive with 3M General Purpose Adhesive Remover (Part Number 051135).

NOTES

Harley-Davidson cannot ensure the results when affixing this insert to any other surfaces or materials. Improper fit or damage to surfaces can occur.

Ambient application temperature should be between 70 and 100 degrees Fahrenheit (21 to 38 degrees Centigrade).

The insert uses a pressure sensitive adhesive backing. The protective film must not be removed from the adhesive until the moment of application to avoid unnecessary exposure to grease, oil, dust, dirt and human skin oils.

PREPARING THE MOUNTING SURFACE

For maximum bond strength of the insert adhesive, the surface surrounding the insert mounting area must be clean and dry.

To ensure surface cleanliness, clean the area with a mixture of 50 to 70% isopropyl alcohol and 30 to 50% distilled water.

Allow to dry thoroughly! To prevent recontamination of the surface, apply the insert within several minutes of cleaning.

APPLYING THE INSERT

1. See Figure 1. Remove the protective film from the back of the insert (2).

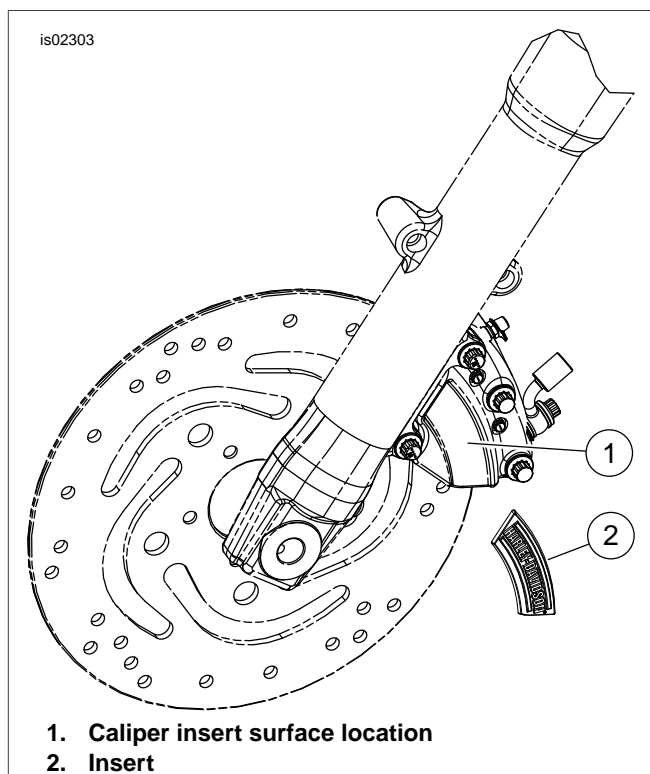

Figure 1. Insert Location

NOTE

For best appearance, carefully align the insert and center the insert on the Caliper Plate from top to bottom, and from left to right.

2. Carefully center the insert on the caliper mounting surface (1).
3. Press the insert firmly into position. Hold the insert in place, pushing hard with your thumbs, for about five seconds. Take care not to shift the insert on the mounting surface.

4. After releasing pressure, avoid direct contact with the insert for 20 minutes.

NOTE

Allow AT LEAST 24 hours after applying the insert before exposing the area to vigorous washing, strong water spray or extreme weather.

The adhesive bond will increase to maximum strength after 72 hours at normal room temperatures.