



# INSTRUCTIONS

-J03335

2005-02-07

## GAUGE BRACKET KITS

### GENERAL

#### Kit Number

See Table 1.

#### Models

See Table 1.

#### Kit Contents

See Table 1.

Table 1. Gauge Bracket Kits

Kit No.	Gauges	Year and Model	Service Parts: Description (Qty) / Part No.
67494-04	1	2004 and later XL Custom	Gauge bracket / Not sold separately
67497-04	1	1996 to 2003 XL Custom	Screw (2) / 3485A
67495-04	2	2004 and later XL Custom	Spacer / 5775
67498-04	2	2000 to 20003 XL Custom	
67496-04	3	2004 and later XL Custom	
67499-04	3	2000 to 20003 XL Custom	
67346-04	1	2000 and later FXSTD, 2005 and later FLSTN	Gauge bracket / Not sold separately
67429-04	2	2000 and later FXSTD, 2005 and later FLSTN	Screw (2) / 4816A
67430-04	3	2000 and later FXSTD, 2005 and later FLSTN	Spacer (2) / 5775
67431-04	1	1996 and later FXST/C	Gauge bracket / Not sold separately
67265-04	1	1996 and later FXSTB, FLSTC, FLSTF, FXDWG	Screw (2) / 4326A
67432-04	2	2000 and later FXST/C	Spacer (2) / 5775
67270-04	2	2000 and later FXSTB, FLSTC, FLSTF, FXDWG	
67433-04	3	2000 and later FXST/C	
67331-04	3	2000 and later FXSTB, FLSTC, FLSTF, FXDWG	
67490-04	1	1996 and later FLSTS, FXSTS	Gauge bracket / Not sold separately
67491-04	2	2000 and later FLSTS, FXSTS	Bracket clamp back / Not sold separately
67492-04	3	2000 and later FLSTS, FXSTS	Screw (2) / 94345-92T Lockwasher (2) / 7041 Acorn nut (2) / 7736
67483-04	1	1996 and later FXD/X/C/XT	Gauge bracket / Not sold separately Screw (2) / 4626A Spacer (2) / 5775
67484-04	1	1996 and later FLHR/C	Gauge bracket / Not sold separately
67485-04	2	2000 and later FLHR/C	Screw (2) / 941
67489-04	3	2000 and later FLHR/C	Washer (2) / 6099 Acorn nut (2) / 7949
67434-04 (2-inch gauge)	1	2004 and later XL 883/1200R, 2004 and later FXD, FXDX, 2005 and later FXDC	Gauge bracket / Not sold separately Screw (2) / 4326A Spacer (2) / 5775
67435-04 (2-inch gauges)	2	2004 and later XL 883/1200R, 2004 and later FXD, FXDX, 2005 and later FXDC	

### ▲ WARNING

Rider and passenger safety depend upon the correct installation of this kit. Use the appropriate service manual procedures. If the procedure is not within your capabilities or you do not have the correct tools, have a Harley-Davidson dealer perform the installation. Improper installation of this kit could result in death or serious injury. (00333b)

### NOTE

This instruction sheet references Service Manual information. A Service Manual for your model motorcycle is required for this installation and is available from a Harley-Davidson Dealer.

### Additional Parts Required

Installation of the single or dual 2 inch Gauge Bracket Kits on 2004 XL 883/XL 1200R and the 2004 and later FXD, FXDX, FXDC models will require a handlebar mounting clamp (chrome: Part No. 56567-86B or black: Part No. 56115-95) to replace the four-inch gauge bracket/handlebar mounting clamp.

## INSTALLATION

### Prepare the Motorcycle

#### ▲ WARNING

Gasoline can drain from quick-connect fitting when removing fuel line. Gasoline is extremely flammable and highly explosive, which could result in death or serious injury. Wipe up spilled fuel immediately and dispose of rags in a suitable manner. (00267a)

1. **For EFI models:** Follow the instructions found in the Service Manual to purge the fuel supply of high pressure gasoline and remove the fuel supply line.
2. **For all models:** Follow the instructions found in the Service Manual to remove the seat and any side covers.

#### ▲ WARNING

To prevent accidental vehicle start-up, which could cause death or serious injury, disconnect negative (-) battery cable before proceeding. (00048a)

3. Disconnect the negative (-) battery cable from the battery.

#### ▲ WARNING

Excessive pressure can build in the fuel tank if vapor valve is not mounted vertically with long fitting to top. Leaks due to excessive pressure can cause a fire or explosion, which could result in death or serious injury. (00265a)

4. **For carbureted models:** Turn the fuel supply valve to OFF. Remove the fuel line from the valve.
5. Follow the instructions in the Service Manual to remove the fuel tank.

#### NOTE

Up to 3 gauges may be installed in a single gauge cluster bracket. Follow the instruction sheets found in the additional gauge kits to prepare the motorcycle. Continue to follow the instructions thru routing the wire harness, installing the gauges, wiring the power, sensor and ground leads, returning the motorcycle to service and testing the operation of each gauge.

6. **For all models except FLHR:** Follow the instructions in the Service Manual to remove the headlamp housing.

### Install Bracket on Handlebar Clamp

1. See Figure 1. Remove two handlebar clamp screws depending on the bracket variation for the model and year.
2. Place spacers into the empty clamp screw counterbores.
3. Loosely secure gauge mount and tach assembly to handlebar clamp with the capscrews.
4. Loosen the opposite pair of clamp screws until the clamp and riser separate at the front and rear.
5. Verify centering of handlebars and position for rider posture.

is00063

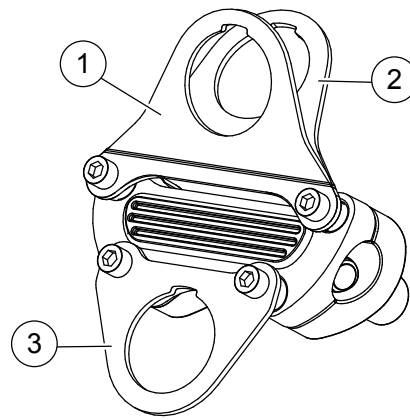

1. Angle forward (FLSTC, FLSTF, FCXWG, FXSTD, FLSTN, XL (2-inch gauge brackets FXD, FXDX, FXDC)
2. Angle back (FXST, FXSTC)
3. Single behind handlebars (FXD, FXDX, FXDXT, FXDC)

Figure 1. Handlebar Clamp Bracket Orientation (illustration for placement/identification)

6. **For XL Custom:** See Figure 2. Tighten front capscrews to 12-18 ft-lbs (16-24 Nm) and then tighten rear capscrews to 12-18 ft-lbs (16-24 Nm).
7. For Dyna Glide and Softail models with cast-in spacer: Tighten the two rear clamp screws until the cast-in spacers contact at the rear. Do not tighten completely.
  - a. Tighten front capscrews to 12-15 ft-lbs (17-20 Nm).
  - b. Tighten rear capscrews to 12-15 ft-lbs (17-20 Nm).
8. For Dyna Glide and Softail models without cast-in spacer: Tighten all four screws finger-tight, maintaining equal gaps between upper and lower clamps front to back.
  - a. Tighten front capscrews to 12-15 ft-lbs (17-20 Nm).
  - b. Tighten rear capscrews to 12-15 ft-lbs (17-20 Nm).

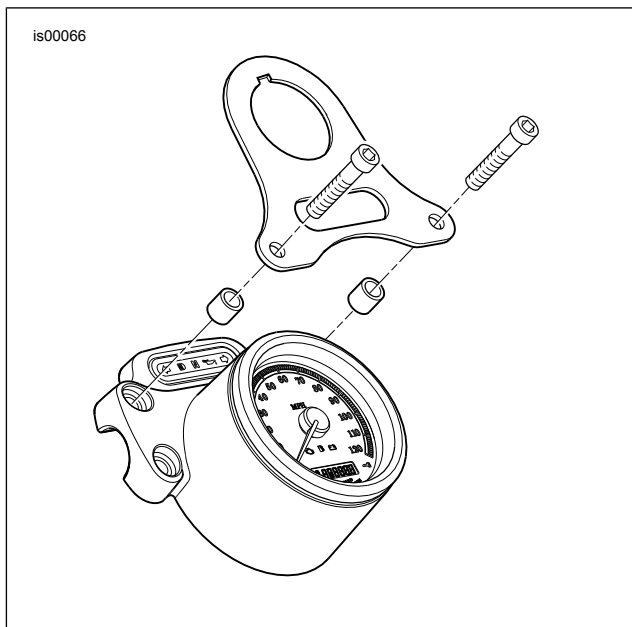

Figure 2. Front Mount Bracket - XL Custom

### Install Bracket on Handlebar Clamp: 1996 and later FLSTS and FXSTS

1. See Figure 3 . Between the handlebar risers, clamp the handlebar between the clamp plate and the gauge mount.
2. Insert capscrews into mounting holes.
3. Add a lockwasher and acorn nut to the capscrews.
4. Position the gauge bracket for rider vision and tighten capscrews to 29 ft-lbs (39 Nm).

#### NOTE

The gap between the tach mount and the clamp plate should be the same on each side.

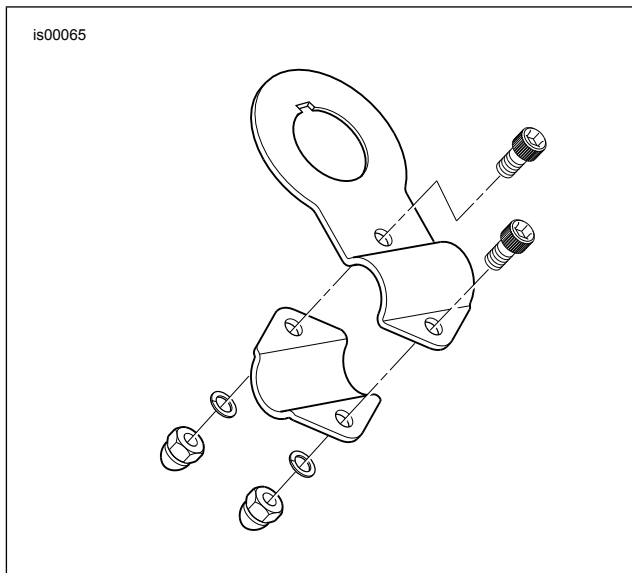

Figure 3. Handlebar Clamp Style Bracket (FLSTS, FXSTS)

### Replace OE Four-Inch Bracket with Two-Inch Gauge Bracket: 2004 and later

## XL 883/XL 1200R, 2004 and later FXD, FXDX, 2005 and later FXDC

### Remove Four-Inch Gauge Bracket

1. See Figure 4. Unthread trip odometer reset boot from back of speedometer housing.
2. Remove screws holding speedometer/tachometer housing backing plate(s). Remove backing plate and rear gasket.
3. Open latches on the speedometer/tachometer connector(s) and separate the socket connector(s) from the pin connector(s).
4. Push the speedometer/tachometer and front gasket(s) out of the bracket.
5. Pull the bulb socket and leads from the indicator lamps housing.

#### NOTE

A new indicator lamp housing found in the two-inch speedometer gauge kit will replace the Original Equipment (OE) housing, mask and lens.

6. If the four-inch bracket is also the handlebar clamp, support the handlebars and remove the four fasteners and lockwashers to remove the bracket/clamp.

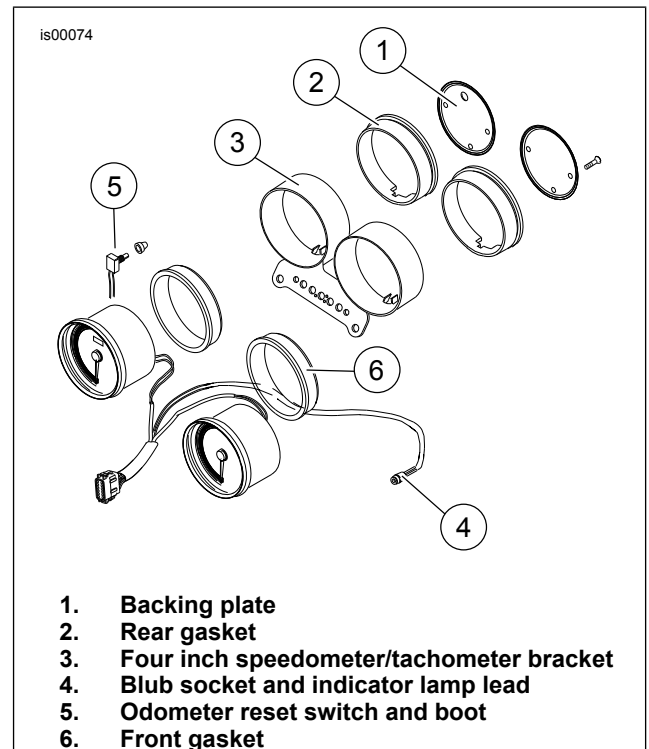

Figure 4. Four-Inch Speedometer/Tachometer (XL 1200R and FXDX)

### Install Two-Inch Gauge Bracket

1. Follow Service Manual procedure to install the handlebar clamp.

#### NOTE

If the speedometer/tachometer bracket is integral with the handlebar top clamp, a separate handlebar clamp (Black: Part No. 56115-95 or Chrome: Part No. 56567-86B) will be required to complete the gauge bracket installation.

2. Follow the instructions found in the two-inch speedometer gauge kit to install the indicator lamp housing from the gauge kit into the gauge bracket.

3. Fit the spacers and gauge bracket over the front holes on the handlebar clamp and install the capscrews.
4. Follow Service Manual procedures to install handlebars. Tighten to specification.
5. Follow instructions in the two-inch speedometer/tachometer kit(s) to install the gauge(s).

### Install Bracket on FLHR Handlebar Shroud: 1996 and later FLHR/C/I

#### Remove FLHR Handlebar Shroud

1. Follow instructions in the Service Manual to remove right saddlebag and right side cover.

#### NOTE

The following adjustment creates room between the inside of the windshield and the top of the nacelle.

2. To create room between the inside of the windshield and the top of the nacelle:
  - a. Remove windshield.
  - b. Loosen, but do not remove, the upper and lower nacelle/passing lamp bracket acorn nuts.
  - c. Apply constant pressure to lower portion of nacelle, toward rear of motorcycle, and move lower windshield bushings as far back as possible, then tighten lower acorn nuts to 18 ft-lbs (24 Nm).
  - d. Apply constant pressure to upper portion of nacelle, toward rear of motorcycle, and move the upper windshield bushings as far forward as possible, then tighten upper acorn nuts to 18 ft-lbs (24 Nm).
3. See Figure 5. Remove screw (1), headlamp door (chrome ring) (2), and headlamp screws (3). Retain screws.
4. Separate electrical connector and remove headlamp assembly (4).
5. Remove speednut (5) that holds chrome trim strip (6) in place and remove trim.
6. Carefully pry off fork lock cover plate (1) on top of nacelle handlebar shroud to access screws that hold cover in place.
7. Under plate, remove 2 screws (11) that hold shroud to fork lock.
8. Remove nut (7) that secures the handlebar shroud and remove shroud, screw (9) and fender washer (8).

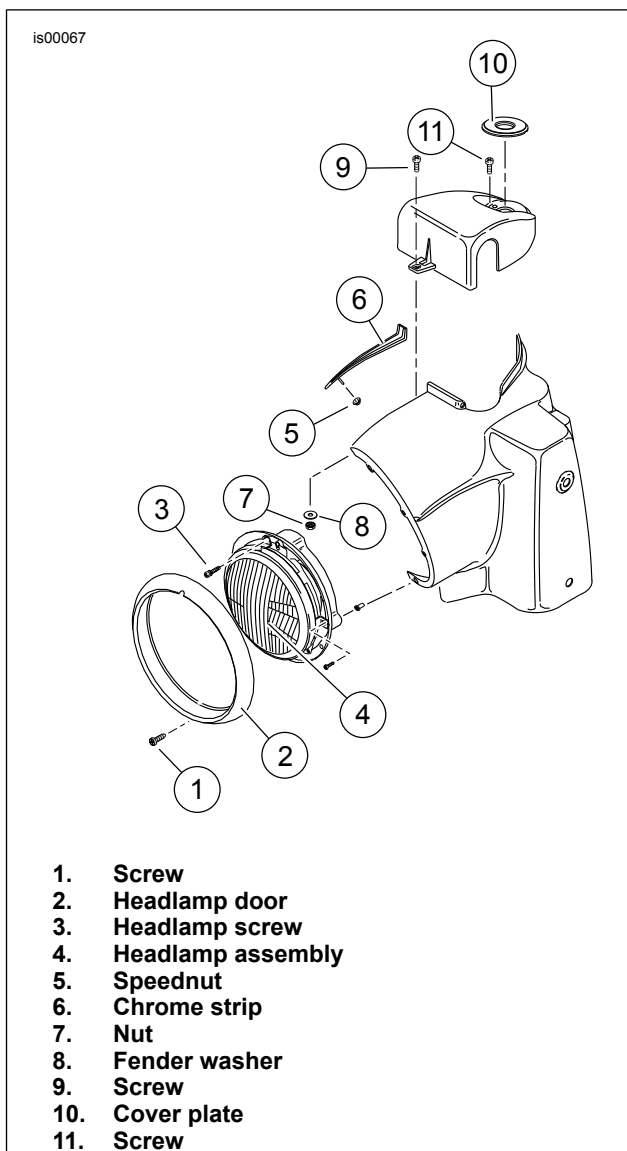

Figure 5. Nacelle and Handlebar Shroud

#### Install Bracket on Shroud

#### NOTE

For best results, drill the gauge bracket holes on a drill press with the drilling surface level. Be sure to use a sharp drill bit when drilling holes in the shroud.

1. Cover the front of the handlebar cover with transparent or masking tape.
2. See Figure 6. Measure and mark the gauge bracket hole locations.
  - a. **For 1996 to 2002 models:** Hole locations are 1-7/8 in. (47.63 mm) from the bottom front of shroud and 3-13/16 in. (96.84) apart and centered on the front face of the shroud.
  - b. **For 2003 and later models:** Hole locations are 1-5/8 in. (41.28 mm) from the bottom front of shroud and 3-13/16 in. (96.84) apart and centered on the front face of the shroud.
3. Center punch hole locations. Drill 1/8 in. starter hole and finish with a 9/32 in. drill bit. Remove the tape and any burrs that may have formed.

4. See Figure 6. Attach gauge bracket to shroud with screws, lockwashers and nuts.
5. Tighten to 84-108 **in-lbs** (9-12 Nm).

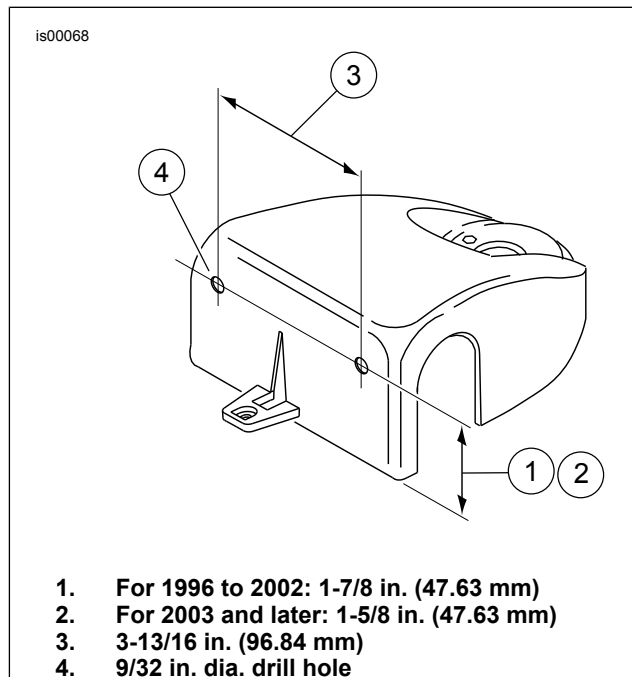

Figure 6. Bracket Hole Locations in FLHR Shroud

### Install FLHR Handlebar Shroud

1. Fit the handlebar shroud over the handlebar clamps.
2. Install the screw through the shroud and the nacelle and from the inside of the nacelle, fit the fender washer and thread on the nut.
3. Tighten the screw to 10-20 **in-lbs** (1.1-2.3 Nm).
4. Install the 2 screws that secure the shroud to the fork lock.
5. Install the cover plate.
6. Fit the chrome strip and reach inside the nacelle to install the speed nut. Tighten speed nut to 15-20 **in-lbs** (1.7-2.3 Nm)
7. Mate the wire connector to the back of the headlamp.
8. Install the headlamp with the 8 screws.
9. Fit the square-shaped portion of the headlamp door spring into the slot at the top of the headlamp housing and then snap the headlamp door (chrome ring) into place. Install the screw at the bottom of the headlamp door.
10. Install the windshield.

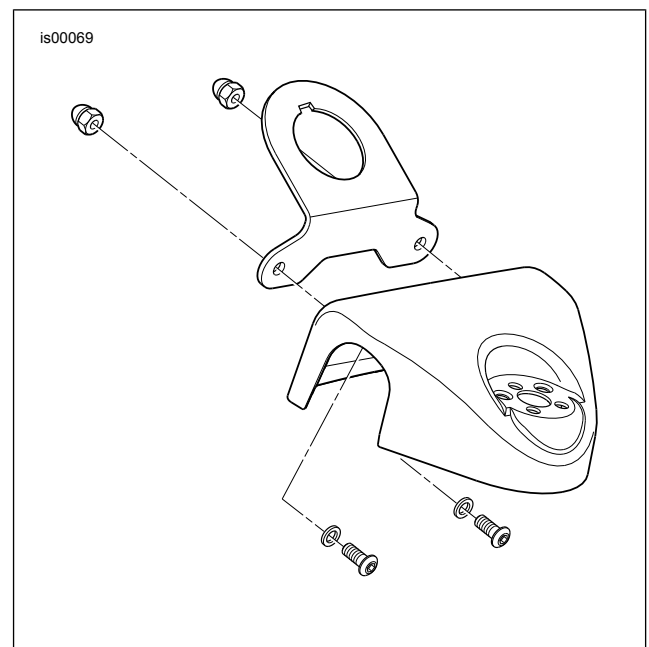

Figure 7. Handlebar Shroud Bracket

### Install Gauge(s) and Wire the Harness

#### NOTICE

It is possible to overload your vehicle's charging system by adding too many electrical accessories. If the combined electrical accessories operating at any one time consume more electrical current than the vehicle's charging system can produce, the electrical consumption can discharge the battery and cause damage to the vehicle's electrical system. See an authorized Harley-Davidson dealer for advice about the amount of current consumed by additional electrical accessories or for necessary wiring changes. (00211c)

#### ⚠ WARNING

When installing any electrical accessory, be certain not to exceed the maximum amperage rating of the fuse or circuit breaker protecting the affected circuit being modified. Exceeding the maximum amperage can lead to electrical failures, which could result in death or serious injury. (00310a)

1. Follow the gauge instructions to install the isolation gasket(s) into the bracket and the gauge(s) into the gasket(s).
2. Follow the gauge instructions to install the gauges(s).
3. Follow the instructions in the gauge housing kit to attach the housings(s).

### Return the Motorcycle to Service

1. **For All models except FLHR:** Follow the instructions in the Service Manual to install the headlamp assembly.
2. Follow the Service Manual instructions to install the fuel tank, attach the fuel line or fittings and add fuel.
3. Connected the negative (-) battery cable to the battery.

#### ⚠ WARNING

After installing seat, pull upward on seat to be sure it is locked in position. While riding, a loose seat can shift causing loss of control, which could result in death or serious injury. (00070b)

4. install the seat and any side covers.
5. Follow the gauge instructions to test the gauge(s).

## **SERVICE PARTS**

See Table 1.