



# INSTRUCTIONS

-J02878

2006-02-13

## BILLET STORAGE TUBE KIT

### GENERAL

#### Kit Number

64100-03, 64101-03, 64120-06

#### Models

These kits fit 2000 and later Dyna® and Softail® and 2000-2003 XL (Sportster®), motorcycles.

Kit Number 64100-03 consists of a 7 inch storage tube and mounting components. Kit Number 64101-03 consists of a 10 inch storage tube and mounting components. Kit Number 64120-06 consists of a 7 inch mini storage tube and mounting components.

#### Kit Contents

Table 1. Kit Contents

Description (Quantity)	Part Number
Assembly clamp	Not Sold Separately
O-ring, cap seal (2)	Not Sold Separately
Cap, threaded (2)	Not Sold Separately
Body, storage	Not Sold Separately
Screws, socket head (3)	Not Sold Separately

There are no Service Parts available with this kit, however, the following Service Kits may be purchased:

Table 2. Available Service Kit

Description (Quantity)	Part Number
Kit, storage tube cap (contains threaded cap and O-ring)	63888-03
Kit, mini storage tube cap (contains threaded cap and O-ring)	64126-06
Kit, storage tube clamp (contains clamp and three screws)	64112-03
Kit, mini storage tube clamp (contains clamp and three screws)	64123-06
Kit, storage tube screw (contains two O-rings and three screws)	64107-03
Kit, mini storage tube screw (contains two O-rings and three screws)	64127-06

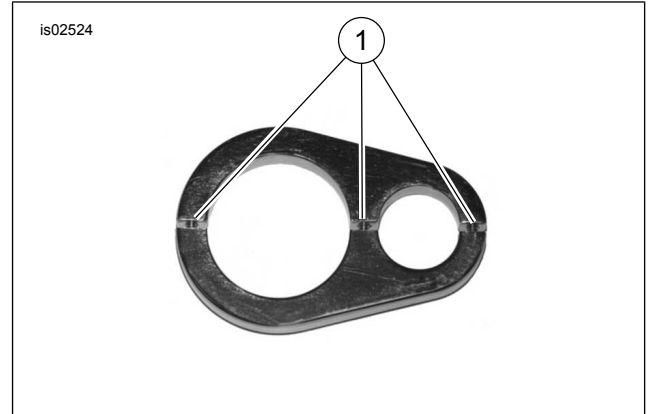
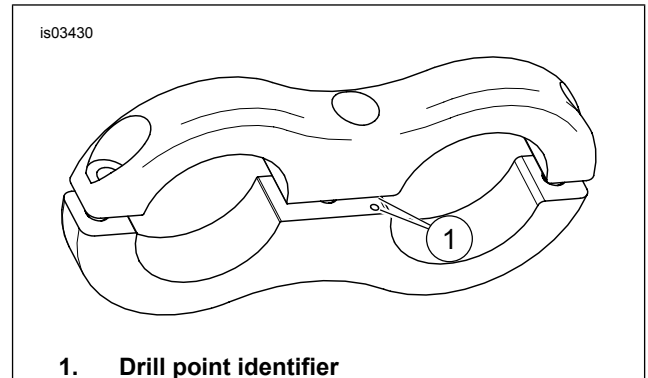


Figure 1. Clamp Gap (Clamp Shown for Kits 64100-03 & 64101-03)



1. Drill point identifier

Figure 2. Mini Storage Tube Clamp (Kit 64120-06)

### INSTALLATION

1. Obtain storage tube, mounting clamp and three screws from kit. Review the photos in this instruction sheet illustrating various models and mounting options to help you decide where the mounting tube will be located. If you have a model other than illustrated, reference the location which most closely resembles your bike however, please note the following:
  - a. The frame tube, clutch cable and clutch cable adjuster must provide adequate clearance for storage tube mounting, especially on the left side.
  - b. Whether mounting storage tube to left or right side, position the tube so it will clear the feet, forward controls, fenders, brake lines, exhaust pipes, exhaust pipe guards, engine guard and engine rubber mounts. On models with rubber mounted engines, you must allow 3/8 to 1/2 inch clearance between tube and engine components.
  - c. You must be able to turn the handlebars lock to lock (full left and full right) without contact or interference from the tube when suspension is fully compressed.
  - d. On XL models, the storage tube cannot be mounted if bike is equipped with an Oil Cooler or with Billet Clutch Cable Adjuster Cover, part number 64108-03.



- e. The storage tube caps are assembled with a slight amount of ANTI-SEIZE applied to the threads on both upper and lower caps. Wipe excess away.

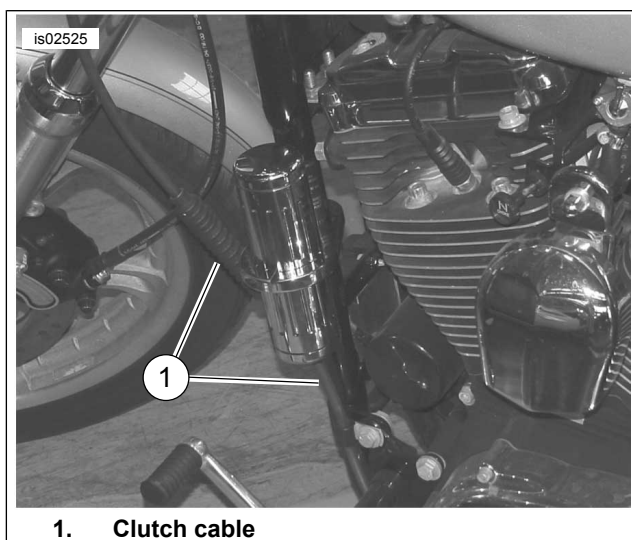
**NOTE**

See Figure 2. When installing a Mini Storage Tube kit, ensure that the clamp halves are oriented so that the portion of the clamp with the drill point indicators (1) attaches to the motorcycle frame.

- 2. See Figure 1. Using the three mounting screws, secure the storage tube to the frame downtube. Tighten screws to 24 in-lbs (2.7 Nm). When storage tube is properly mounted, the gap between the clamp halves will be equal at the three locations shown.

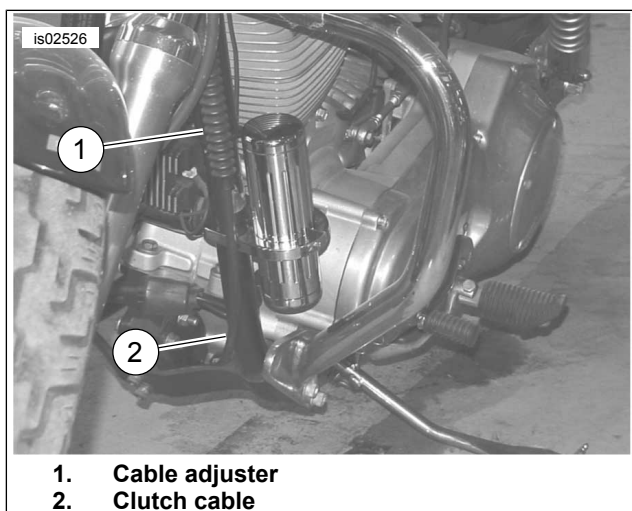
**MOUNTING LOCATIONS**

**Sporster Models:** See Figure 3. The preferred mounting location is on the left side front frame downtube since the exhaust system will prevent mounting on the right side in most cases. Note that clutch cable routing is not affected when tube is mounted at this left front downtube location.



1. Clutch cable

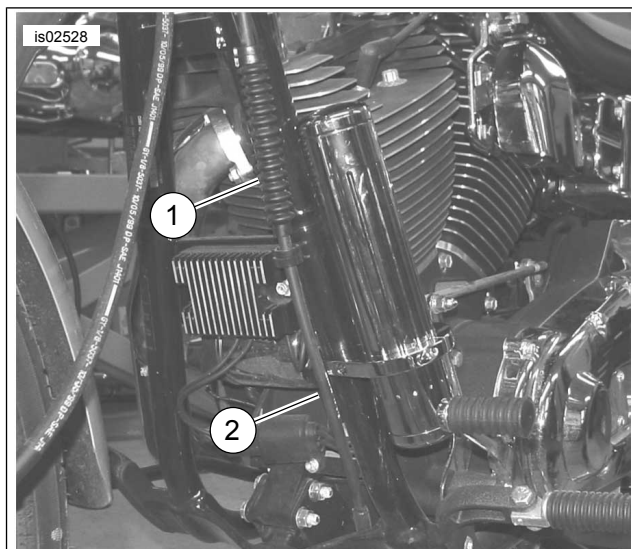
**Figure 3. Mounting Location (Left Side XL Sportster Shown)**



1. Cable adjuster  
2. Clutch cable

**Figure 4. Mounting Location (Left Side of FXDX Shown)**

**FXDX, FXDXT and FXDS Dyna Models:** See Figure 4. The preferred mounting location is on the right side front frame downtube as more open space is available however, the storage tube can be mounted to the left side as shown. Care must be taken to avoid interference with clutch cable (2) and cable adjuster (1).



1. Cable adjuster  
2. Clutch cable

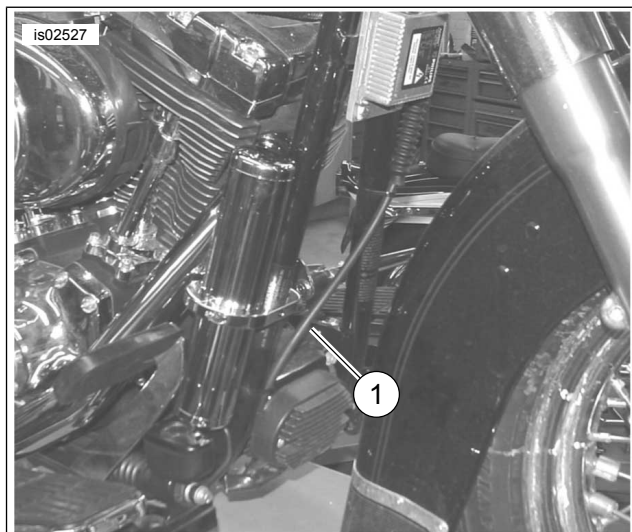
**Figure 5. Mounting Location (Left Side of FXDWG Shown)**

**NOTE**

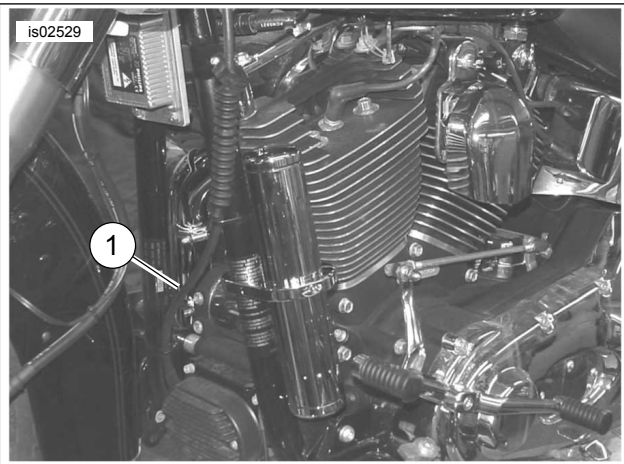
The clamp must be positioned below the tube transition (crossmember) with at least 2-1/2 inches of tube clamped above bottom for the 10 inch storage tube.

**FXDWG Dyna Models:** See Figure 5. The preferred mounting location is on the right side front frame downtube as more open space is available, however, the tube can be mounted on the left side if care is taken to avoid interference with clutch cable.

**Softail Models:** See Figure 5. The preferred mounting location is on the right side front frame downtube as more open space is available, however, the tube can be easily mounted on the left side (See Figure 7.) if care is taken to avoid interference with clutch cable and cable routing. See Figure 6 and Figure 7 for FLSTC left and right mounting locations and Figure 8 for FXSTD (Deuce) left side mounting.

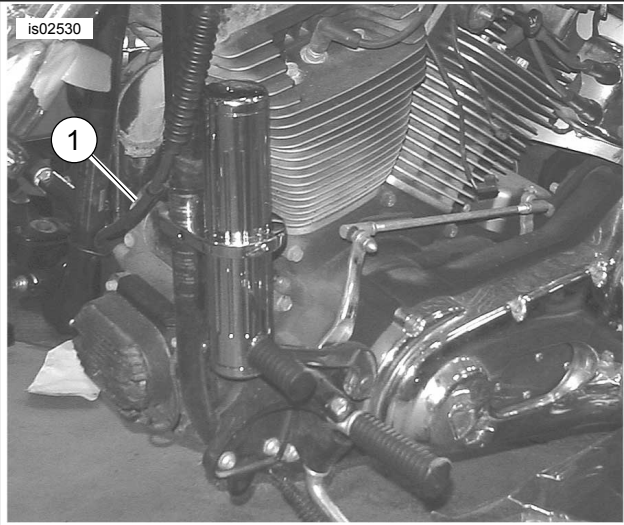


**Figure 6. Mounting Location (Right Side of FLSTC Shown)**



**1. Clutch cable**

**Figure 7. Mounting Location (Left Side of FLSTC Shown)**



**1. Clutch cable**

**Figure 8. Mounting Location (Left Side of FXSTD Shown)**