



INSTRUCTIONS

-J02665

2006-08-10

DUAL MASTER CYLINDER REBUILD KIT

GENERAL

Kit Number

42809-04B

Models

This kit fits all 2004 - 2006 XL models equipped with dual disc front brakes.

▲ WARNING

Rider and passenger safety depend upon the correct installation of this kit. Use the appropriate service manual procedures. If the procedure is not within your capabilities or you do not have the correct tools, have a Harley-Davidson dealer perform the installation. Improper installation of this kit could result in death or serious injury. (00333b)

NOTE

This instruction sheet references Service Manual information. A Service Manual for your model motorcycle is required for this installation and is available from a Harley-Davidson dealer.

Kit Contents

Table 1. Kit Contents (Sold Components)

Qty	Description	Part Number
1	Retaining ring, piston	11142
1	Retaining ring, lever pivot pin	11379
1	Brake grease, G40M	42820-04
1	Brake grease, CCI #20	42830-05
2	Sealing washer	41743-04

REMOVAL

- See Figure 1. Loosen turn signal clamp screw (3) and remove turn signal assembly (5) from front brake master cylinder housing (1).
- Loosen and remove locknut and washer (4), and lift mirror (2) from master cylinder housing.
- See Figure 2. Remove bleeder nipple cap (2) from bleeder valve (3) on front brake caliper (1). See Figure 3. Install end of a length of clear plastic tube (1) over caliper bleeder valve, while placing free end in a suitable container (2). Open bleeder valve about 1/2 turn. Pump brake hand lever to drain brake fluid. Close bleeder valve.
- See Figure 1. Remove banjo bolt (7) and two washers (8) to disconnect hydraulic brake line banjo fitting (6) from master cylinder (1). Discard washers.

NOTE

Use the eyelet of an ordinary cable strap if the cardboard insert is not available.

- See Figure 4. Squeeze front brake lever and place a 5/32 inch (4 mm) thick cardboard insert between brake lever and lever bracket. Release brake lever.

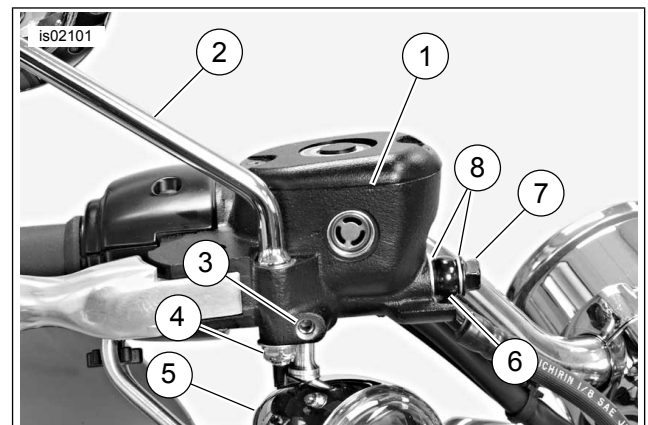

- Front brake master cylinder and reservoir
- Mirror
- Turn signal clamp screw
- Mirror locknut and washer
- Turn signal
- Front brake line banjo fitting
- Banjo bolt
- Washer (2)

Figure 1. Front Brake Master Cylinder

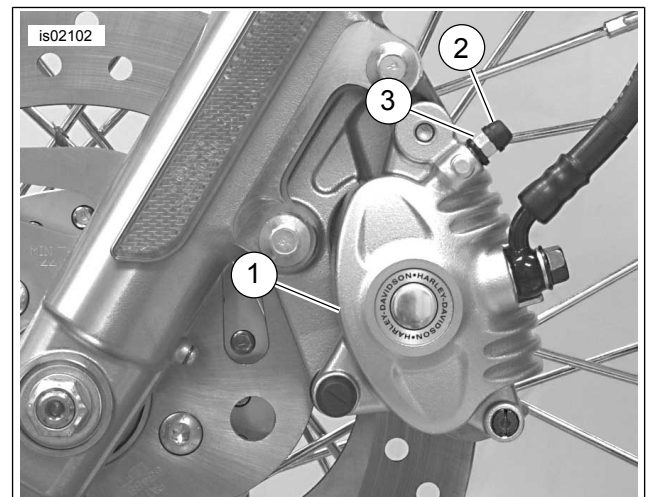

- Front brake caliper
- Bleeder nipple cap
- Bleeder valve

Figure 2. Front Caliper Bleeder Valve



NOTICE

Do not remove or install the master cylinder assembly without first positioning a 5/32-inch (4 mm) thick insert between the brake lever and lever bracket. Removing or installing the master cylinder assembly without the insert in place may result in damage to the rubber boot and plunger on the front stoplight switch. (00324a)

- See Figure 5. Using a T-27 TORX® drive head, remove the two screws (6) and washers (7) securing the handlebar clamp (8) to the master cylinder housing (5). Remove the brake lever/master cylinder assembly and clamp from the handlebar.

DISASSEMBLY

⚠ WARNING

Wear safety glasses or goggles when removing or installing retaining rings. Retaining rings can slip from the pliers and could be propelled with enough force to cause serious eye injury. (00312a)

NOTE

Use correct retaining ring pliers and correct tips. Verify that tips are not excessively worn or damaged.

- See Figure 5. Remove retaining ring (17) from pivot pin groove at bottom of master cylinder bracket. Discard retaining ring.
- Remove pivot pin (9) and brake hand lever (18) from master cylinder assembly.
- Remove and discard dust boot (16).

NOTICE

Clamp front brake master cylinder in a vise by the mirror mounting boss only. Use brass jaw covers or other protective device on vise jaws. (00326a)

- See Figure 6. Clamp master cylinder in a vise so that banjo fitting hole is pointing straight down.
- See Figure 5. Press down on end of piston and remove retaining ring (15). Discard retaining ring.

NOTE

Dual disc master cylinder pistons have only the secondary cup (13) fitted into a groove in the piston body (14). The primary cup (12) fits onto the small end of the piston spring (11).

- Remove and discard piston assembly (12, 13, 14) and piston spring (11).

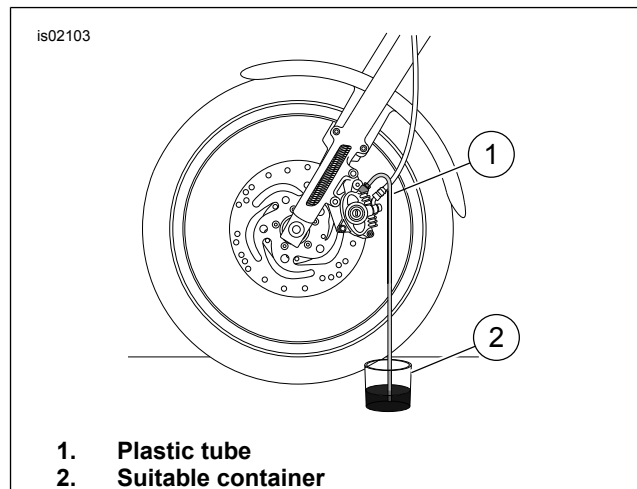

Figure 3. Bleeding Hydraulic System

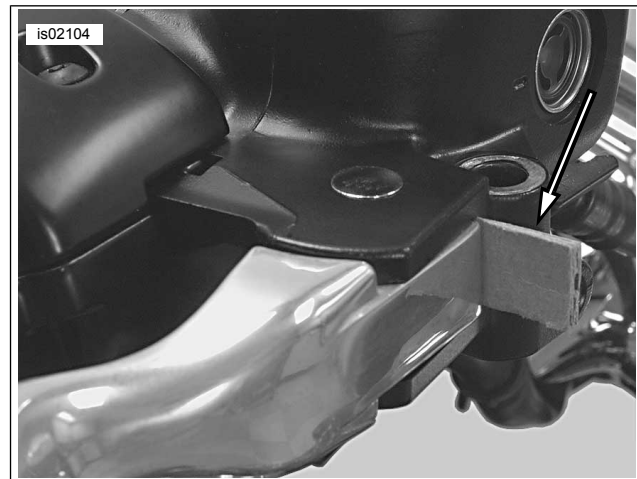
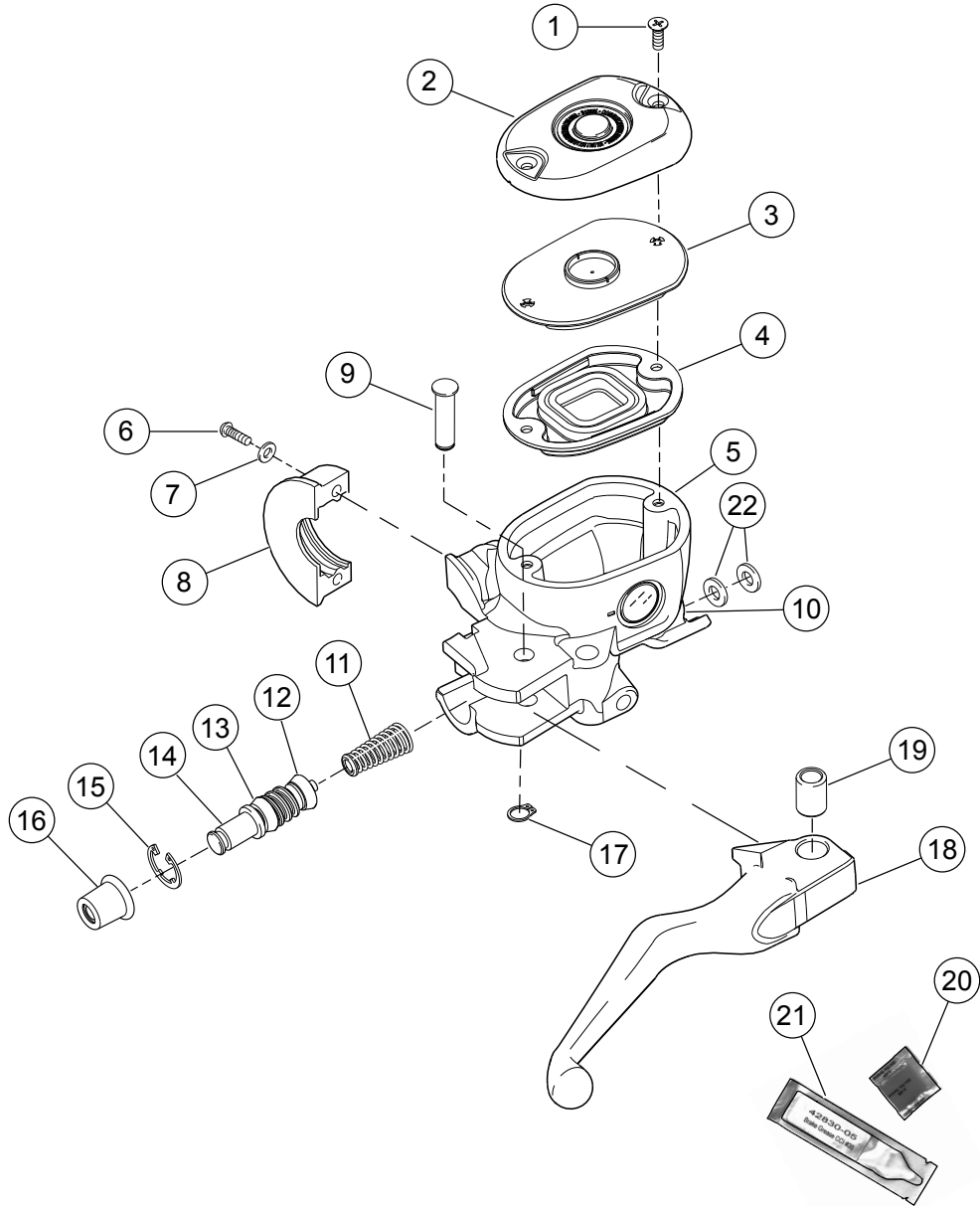

Figure 4. Install Cardboard Insert Before Removing or Installing Master Cylinder Assembly



- | | |
|-----------------------------------|----------------------------|
| 1. Screw (2) | 12. Primary cup* |
| 2. Reservoir cover | 13. Secondary cup* |
| 3. Diaphragm plate | 14. Piston* |
| 4. Diaphragm | 15. Retaining ring* |
| 5. Master cylinder housing | 16. Dust boot* |
| 6. Screw (2) | 17. Retaining ring* |
| 7. Washer (2) | 18. Brake hand lever |
| 8. Handlebar clamp | 19. Bushing |
| 9. Pivot pin | 20. Brake grease, G40M* |
| 10. Banjo fitting seating surface | 21. Brake grease, CCI #20* |
| 11. Spring* | 22. Sealing Washer* (2) |

Figure 5. Master Cylinder Assembly (* - items included kit)

is02105



Figure 6. Clamping Front Master Cylinder (Location)

NOTICE

Do not allow dirt or debris to enter the master cylinder reservoir. Dirt or debris in the reservoir can cause improper operation and equipment damage. (00205c)

- Remove two screws (1), cover (2), diaphragm plate (3), and diaphragm (4) from master cylinder reservoir.

CLEANING, INSPECTION, AND REPAIR

⚠ WARNING

Compressed air can pierce the skin and flying debris from compressed air could cause serious eye injury. Wear safety glasses when working with compressed air. Never use your hand to check for air leaks or to determine air flow rates. (00061a)

⚠ WARNING

Use denatured alcohol to clean brake system components. Do not use mineral-based solvents (such as gasoline or paint thinner), which will deteriorate rubber parts even after assembly. Deterioration of these components can cause brake failure, which could result in death or serious injury. (00291a)

- Clean all metal parts with denatured alcohol. Clean all rubber parts with D.O.T. 5 Silicone Hydraulic Brake Fluid (99902-77). Do not contaminate with mineral oil or other solvents. Wipe dry with a clean, lint free cloth. Blow out drilled passages and piston bore with low pressure compressed air from a clean air supply. Do not use a wire or similar instrument to clean drilled passages in bottom of reservoir.
- Carefully inspect all parts for wear or damage and replace as necessary.
 - Inspect the piston bore in the master cylinder housing for scoring, pitting, or corrosion. Replace the housing if any of these conditions are found.
 - Inspect the outlet port that mates with the brake line banjo fitting. This is a critical sealing surface. Replace the housing if any scratches, dents, or other damage is found.
 - Inspect diaphragm for cuts, tears, or general deterioration. Replace if necessary.

ASSEMBLY

⚠ WARNING

Do not use parts from single caliper repair kits (9/16 inch bore) on dual caliper models. Likewise, do not use parts from dual caliper repair kits (11/16 inch bore) on single caliper models. Using incorrect parts can cause brake failure, which could result in death or serious injury. (00278a)

NOTE

Always reassemble the master cylinder using new parts from the correct service repair kit.

Brake grease CCI #20 (42830-05) is recommended for lubrication of cylinder bore, cups, and seals prior to assembly.

NOTICE

Clamp front brake master cylinder in a vise by the mirror mounting boss only. Use brass jaw covers or other protective device on vise jaws. (00326a)

- Clamp master cylinder in a vise so that banjo fitting hole is pointing straight down.
- See Figure 5. Coat piston bore of master cylinder housing (5), piston (14), primary cup (12), and secondary cup (13) with brake grease CCI #20 (42830-05).
- See Figure 7. Install piston assembly into master cylinder.
 - Press primary cup (4) onto small end of piston spring (5). Insert flared end of spring into master cylinder bore so that it seats against the counter bore (recess) at bottom. Slide piston into bore over primary cup/spring assembly.

is02113

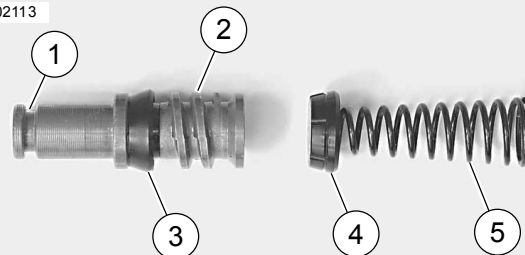

- Dust boot groove
- Dual piston
- Secondary cup
- Primary cup
- Piston spring
- Brake grease, CCI #20 (not shown)

Figure 7. Front Master Cylinder Piston (Dual Disc)

⚠ WARNING

Wear safety glasses or goggles when removing or installing retaining rings. Retaining rings can slip from the pliers and could be propelled with enough force to cause serious eye injury. (00312a)

- See Figure 5. Press down on piston body (14) and install new retaining ring (15) from kit. Verify that retaining ring is fully seated in groove.
- Install dust boot (16). Large lip of dust boot fits down inside end of piston bore. Small lip of dust boot fits into groove in end of piston (item 1, Figure 7).

6. Apply approximately 0.1 g G40M (42820-04) brake grease (from service parts kit) to each of the following two locations:
 - a. Pivot hole in brake lever (18).
 - b. End of piston (14).
7. Align hole in brake hand lever (18) with hole in master cylinder bracket. From top of assembly, slide pivot pin (9) through bracket and hand lever.
8. Install new retaining ring (17) from kit in pivot pin groove. Verify that retaining ring is fully seated in groove.
9. Remove master cylinder assembly from vise. Install cover (2), diaphragm plate (3), and diaphragm (4) on master cylinder reservoir. Install two screws (1) to fasten cover to reservoir, but do not tighten at this time.
10. See Figure 4. Squeeze front brake lever and place a 5/32 in. (4 mm) thick cardboard insert between brake lever and lever bracket. Release brake lever.

INSTALLATION

NOTICE

Do not remove or install the master cylinder assembly without first positioning a 5/32-inch (4 mm) thick insert between the brake lever and lever bracket. Removing or installing the master cylinder assembly without the insert in place may result in damage to the rubber boot and plunger on the front stoplight switch. (00324a)

1. See Figure 8. Position brake lever/master cylinder assembly inboard of switch housing assembly (1) engaging tab (5) on lower switch housing in slot (4) at top of brake lever bracket (3).

NOTE

Master cylinder housing has a positive stop for banjo fitting. When tightening banjo bolt into master cylinder in the next step, rotate banjo fitting clockwise until it contacts positive stop.

2. Align holes in handlebar clamp with those in master cylinder housing and start two screws. Position for rider comfort. Beginning with top screw, tighten screws to 108-132 in-lbs (12.2-14.9 Nm) using a T27 Torx® drive head.

NOTICE

Avoid leakage. Be sure gaskets, banjo bolt(s), brake line and master cylinder bore are clean and undamaged before assembly. (00322a)

3. See Figure 1. Position a new sealing washer (8), supplied in the kit, on each side of hydraulic brake line banjo fitting (6). Insert banjo bolt (7) through washers and fitting. Thread bolt into master cylinder housing. Tighten to 20-25 ft-lbs (27.1-33.9 Nm).

NOTE

See Figure 9. Do not use sight glass (2) to determine maximum fluid level. Sight glass should only be used as a visual indicator that fluid level is low and needs attention. A cast-in ridge (1) is located on the inside of the reservoir to assist you in determining the correct level.

Use only D.O.T. 5 Silicone Hydraulic Brake Fluid from a sealed container.

Do not overfill reservoir. Do not reuse old brake fluid.

4. Position motorcycle so that top of master cylinder reservoir is level. See Figure 5. Remove two screws (1), front master cylinder reservoir cover (2), diaphragm plate (3), and diaphragm (4).

⚠ CAUTION

Direct contact of DOT 5 brake fluid with eyes can cause eye irritation, swelling, and redness. Avoid eye contact. In case of eye contact flush with large amounts of water and get medical attention. Swallowing large amounts of DOT 5 brake fluid can cause digestive discomfort. If swallowed, obtain medical attention. Use in well ventilated area. KEEP OUT OF REACH OF CHILDREN. (00144b)

5. See Figure 9. Add enough D.O.T. 5 Silicone Hydraulic Brake Fluid (99902-77) to reservoir to bring fluid level even with cast-in ridge (1) inside of reservoir, 1/4 in. (6.4 mm) below top edge.

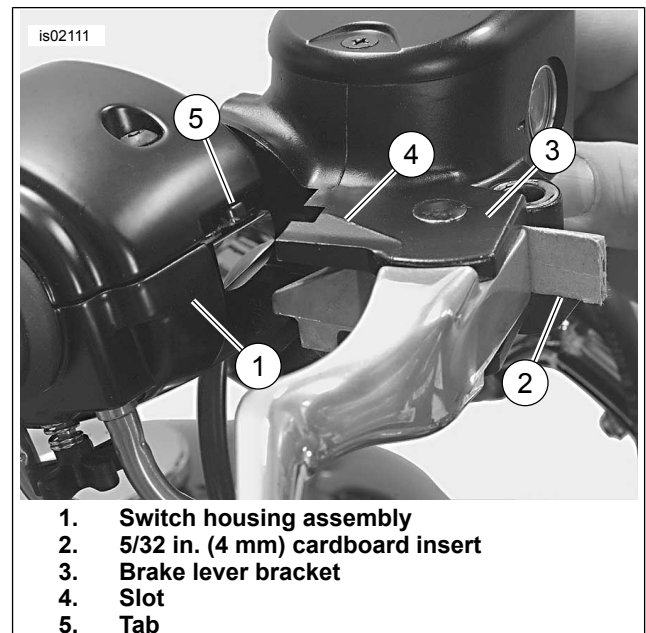

Figure 8. Fitting Brake Lever/Master Cylinder to Right Handlebar Switch Housing

⚠ WARNING

Be sure the master cylinder relief port is not plugged. A plugged relief port can cause brake drag or lockup and loss of vehicle control, which could result in death or serious injury. (00317a)

6. Verify proper operation of master cylinder relief port. Actuate brake hand lever with reservoir cover removed. A slight spurt of fluid will break fluid surface in reservoir compartment if all internal components are working properly.
7. See Figure 2. Install length of clear plastic tubing over front brake caliper bleeder valve (3). Place free end of tube in a clean container.

8. See Figure 9. Add enough D.O.T. 5 Silicone Hydraulic Brake Fluid (99902-77) to reservoir to bring fluid level even with cast-in ridge (1) inside of reservoir, about 1/4 in. (6.4 mm) below top edge.
9. Depress and hold brake hand lever to build up hydraulic pressure.
10. Open front caliper bleeder valve about 1/2-turn. Brake fluid will flow from bleeder valve through tubing. Close bleeder valve when brake hand lever has moved approximately 1/2 to 3/4 of its full range of travel. Allow brake hand lever to return slowly to its released position.
11. Repeat Steps 8-10. until all air bubbles are purged.

NOTE

On models with two brake calipers, repeat Steps 7-12 on second caliper.

12. Final tighten bleeder valve to 35-61 **in-lbs** (3.9-6.9 Nm). Install bleeder nipple cap.
13. See Figure 9. Add enough D.O.T. 5 Silicone Hydraulic Brake Fluid (99902-77) to reservoir to bring fluid level even with cast-in ridge (1) inside of reservoir, 1/4 in. (6.4 mm) below top edge.
14. See Figure 5. Note that angular shape of master cylinder cover (2) makes one side thicker than the other. Install cover with diaphragm plate (3) and diaphragm (4) on master cylinder housing (5) so that thicker side is positioned above brake line banjo fitting. Fasten cover to reservoir with two screws (1). Tighten to 9-17 **in-lbs** (1.0-2.0 Nm).
15. See Figure 1. Install mirror (2), secure with locknut and washer (4). Position mirror for best rearward visibility. Tighten locknut to 96-144 **in-lbs** (10.9-16.3 Nm).
16. Install turn signal (5), secure with clamp screw (3). Position so turn signal lens faces directly forward and turn signal does not strike fuel tank when handlebars are turned full right. Tighten to 96-120 **in-lbs** (10.9-13.6 Nm).
17. With Ignition/Light Key Switch turned to IGNITION, actuate front brake hand lever to verify operation of brake lamp.

▲ WARNING

After repairing the brake system, test brakes at low speed. If brakes are not operating properly, testing at high speeds can cause loss of control, which could result in death or serious injury. (00289a)

18. Test ride motorcycle at low speed. If brake feels spongy, repeat bleeding procedure.



Figure 9. Fitting Brake Lever/Master Cylinder to Right Handlebar Switch Housing