



# INSTRUCTIONS

-J01068

REV. 4-1-86

Kit Number 29130-86, 91729-85

## ROUND AIR CLEANER KIT

This kit is designed for all vehicles which have engines equipped with KEIHIN carburetors.

This kit contains the following parts:

QTY.	DESCRIPTION
1	Backing plate
1	Cover
1	Screw
1	Foam element
1	Venturi
1	Hose, extension
1	Nipple, connecting
1	Self-locking nut
3	Screws (backing plate)
1	Caution label

\*Socket head (29130-86)  
— Phillips head (91729-85)

### Installation Procedure

1. See Figure 1. Disconnect crankcase vent hose at air cleaner fitting if so equipped. Remove existing air cleaner and air cleaner backing plate. If backing plate gasket on face of carburetor is damaged, replace with a new one.
2. Place new backing plate (1) against carburetor face. Position venturi (5) against backing plate (1) and align all holes. Insert socket head screws (9) through venturi (5), through backing plate (1) and thread into tapped holes in carburetor flange. Tighten screws (9) to 7-10 ft-lbs torque.
3. If your vehicle is not equipped with a crankcase

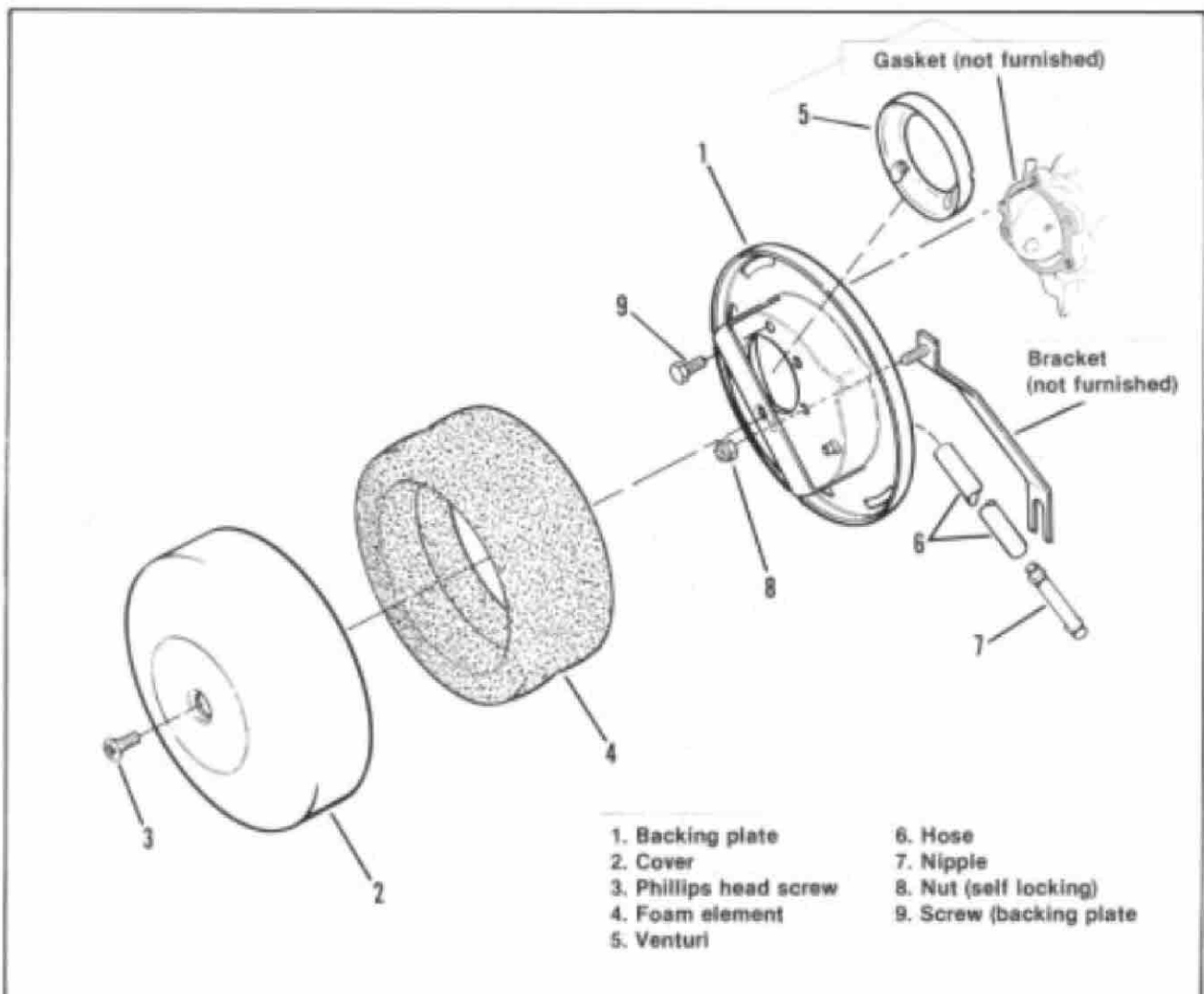

Figure 1. Air Cleaner Assembly

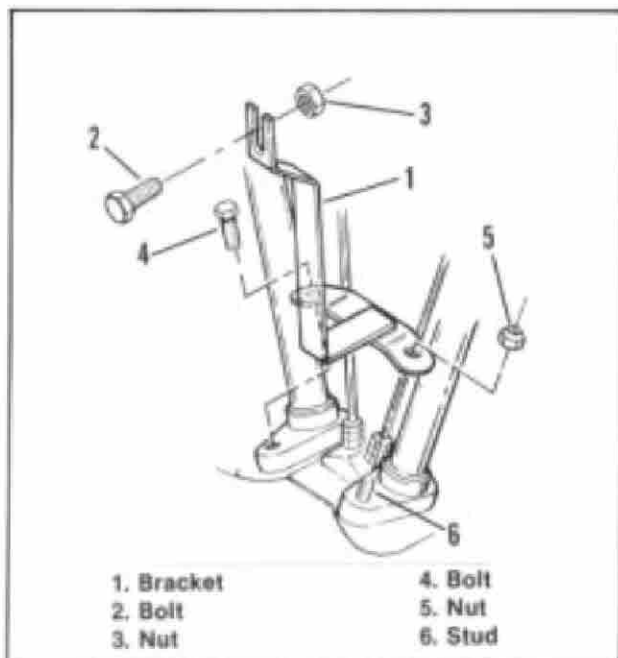

Figure 2. Bracket Mounting — XL Models

vent hose connected to the air cleaner, plug the hole in hose nipple at engine side of backing plate. If your vehicle is equipped with a vent hose to the air cleaner, push one end of extension hose (6) over nipple at engine side of backing plate. Push half of connecting nipple (7) into free end of hose (6). Connect exposed end of nipple (7) to open end of crankcase vent hose.

**CAUTION**

The air cleaner must have the factory authorized support bracket, properly installed, to meet safety requirements. Full information for ordering the correct bracket to fit your particular motorcycle as well as installation instructions is given in this instruction.

- There are four different air cleaner support brackets which are designed to fit different engines. The bracket for 1985 and earlier XL vehicles can be ordered by specifying Harley-Davidson Part No. 29184-85. The bracket for Shovelhead engines can be ordered by specifying Harley-Davidson Part No. 29182-85. The bracket for Evolution™ engines can be ordered by specifying Harley-Davidson Part No. 29183-85. The bracket for 1986 XL's can be ordered by specifying Harley-Davidson Part No. 29193-86. The brackets are installed as follows:

A. XL Vehicles — See Figure 2. Remove nut (5) and bolt (4) at the tappet guide blocks. Place bracket (1) over stud (6) and align holes at adjacent tappet guide block. Thread nut (5) on stud (6). Insert bolt (4) through bracket (1), through tappet guide block mounting hole and thread into tapped hole in crankcase. Insert bolt (2) through backing plate, and slotted end of bracket (1). Thread nut (3) on bolt (2). Tighten bolt (4), nut (5) and nut (3) to a torque of 8-10 ft-lbs.

B. Evolution™ and Shovelhead Engines — See Figure 3. Loosen nut (2) enough to accommodate slotted end of bracket (1). Slide slotted end of bracket (1) over stud (4), insert stud at upper end of bracket (1), through mounting hole in backing plate from the engine side and thread on nut (8), Figure 1. Tighten nut (8) to a torque of 8-10 ft-lbs and nut (2) to a torque of 12-15 ft-lbs.

- Remove the foam element from the wire mesh core. Evenly apply 1 to 1-1/2 tablespoons of engine oil to the filter element with an atomizer or work that amount into the filter by hand. Install foam element in the screen and place into the air cleaner backing plate.

- See Figure 1. Place cover (2) in position over backing plate (1). Insert phillips head screw (3) through cover (2) and thread into tapped hole at center of backing plate. Tighten screw (3) securely.

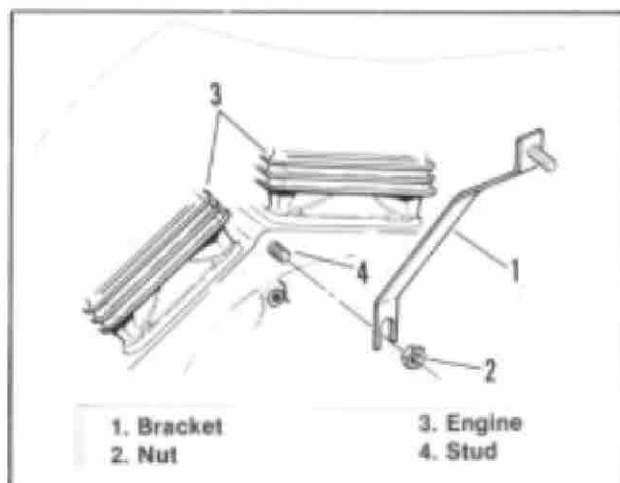

Figure 3. Bracket Mounting — Shovelhead & Evolution™

## SUPPLEMENTARY INSTRUCTION SHEET FOR AIR CLEANER KIT - PART NO. 91729-85

### General

Harley-Davidson recommends the use of a support bracket when installing this air cleaner kit.

The support bracket is not included in this kit and must be purchased separately from your Harley-Davidson dealer. Part No. 29182-85 fits shovelhead engines; 29183-85 fits Evolution 1340cc engines; and 29184-85 fits Sportster engines.

### Procedure

Cut out the attached template and place on the carburetor side of the air cleaner backing plate. Mark centerpunch and drill a  $9/32$  in. hole where indicated.

Return to Step 1 of the enclosed instruction sheet which has an exploded view diagram of the installation procedure.

