



# INSTRUCTIONS

-J00728

REV. 11-27-96

Kit Number 67182-95A

## TACHOMETER KIT

### General

This kit is designed for installation on 1995 and later 883 XLH model motorcycles equipped with an electronic speedometer and no tachometer.

See Service Parts illustration for kit contents.

#### For 1997 and later models:

The tachometer comes assembled with harness wires terminated with Amp sockets and is ready for installation. Begin with INSTALLATION.

#### For 1995-1996 models:

Before installation, the tachometer back must be removed and the wire harness (with wires terminated with Amp sockets) must be replaced with the wires terminated with Deutsch sockets that are provided in the kit. Begin with 1995-1996 TACHOMETER HARNESS.

#### NOTE

A Service Manual for your motorcycle is available from your Harley-Davidson Dealer.

#### CAUTION

**USE THE APPROPRIATE SERVICE MANUAL PROCEDURE!** If the procedure is not within your capabilities or you do not have the correct tools, have your Harley-Davidson dealer perform the installation.

### GENERAL

To install this kit, you will be removing the following: seat, fuel tank, speedometer bracket, speedometer, and indicator lights, in base of speedometer bracket. You will also have to disconnect the electronic speedometer harness from the 3-place connector under the seat and disconnect the 12-place connector under the headlight bracket. Read all the applicable Service Manual instructions carefully before you begin the tachometer installation.

The wiring schematic for this kit is shown in Figure 9.

### 1995-1996 Tachometer Harness

1. Remove the two hex socket flat head screws that hold the back of the tachometer in place with a 3/32 hex bit.
2. See Figure 1. NOTE LOCATION OF EACH WIRE COLOR BEFORE REMOVING ANY WIRE. Remove the 9/32 in. nuts from the three terminal studs, and remove the three harness wires identified in the figure from the studs. Leave the other wires in place.
3. Slide the three terminated wires supplied in kit through the section of conduit supplied in kit.
4. Place ring terminals of wires over studs corresponding to wires removed in step 2 and install nuts to secure wires in place.

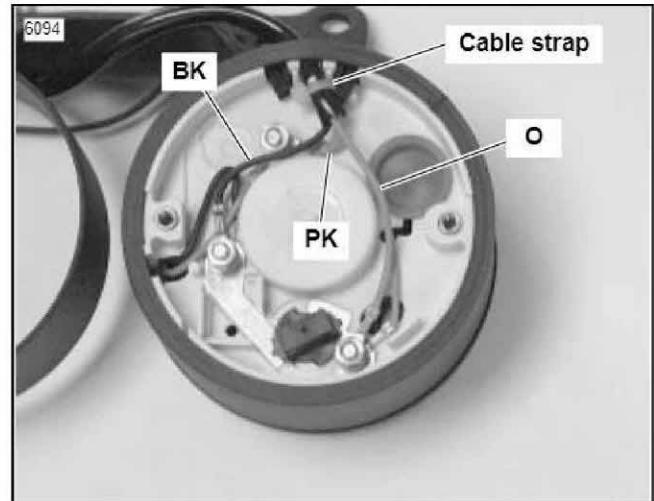

Figure 1. Tachometer Wiring

5. Secure conduit to wires with cable strap in location shown, then install tachometer back cover.

### Installation

#### WARNING

To avoid accidental start-up of vehicle and possible personal injury, disconnect the battery cables before proceeding. Always disconnect the negative cable first. If the positive cable should contact ground with the negative cable installed, the resulting sparks may cause a battery explosion resulting in personal injury.

1. Refer to applicable Service Manual and remove seat and fuel tank following Service Manual procedures.
2. Unplug the 3-place speed sensor connector [65] located under the seat and slide the speedometer harness forward through the cable straps. Cut those straps that will not allow you to move the speedometer harness.
3. See Figure 2. Remove the two bolts that secure the headlamp bracket and allow headlamp and bracket to tilt forward. Unplug the 12-place connector under the headlamp bracket.



Figure 2. Unplugging 12-Place Connector (1995-1996 style connector shown)

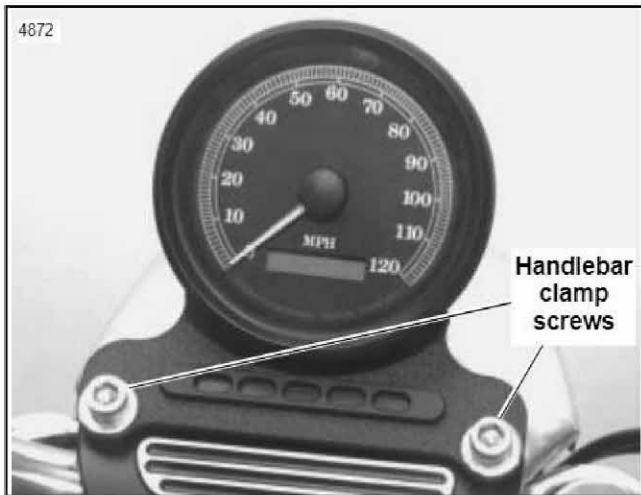

**Figure 3. Removing Speedometer and Bracket**

- See Figure 3. Remove handlebar clamp screws securing speedometer bracket. Remove speedometer and bracket along with associated harnesses and place the assembly on a clean work bench.

**REMOVING SPEEDOMETER LEADS FROM 12-PLACE CONNECTOR**

- See applicable connector information in Service Manual. Remove the following wires and terminals from the 12-place connector (a Deutsch connector for 1995-1996 models; and an Amp connector for 1997 models):

Wire Color	Cavity Number
Orange/White	1
White/Green	2
Black	12

- Remove wires from conduit.

**REMOVING SPEEDOMETER FROM BRACKET**

- Note location of all indicator light components mounted in speedometer bracket. Each indicator lamp has the lamp's function printed on one of the lamps leads. Remove the two screws that secure the indicator light components to the speedometer bracket. Retain screws and indicator light components for installation on speedometer/tachometer bracket later.

- See Figure 4. Unscrew boot from speedometer reset

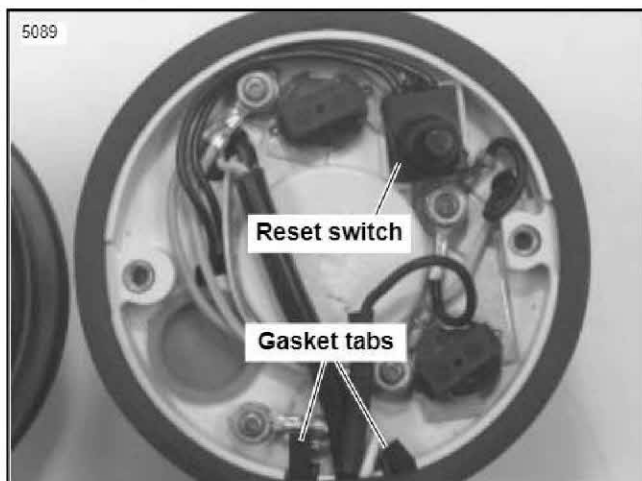

**Figure 4. Rear Cover Removed From Speedometer**



**Figure 5. Removing Speedometer From Bracket**

- switch by turning it counterclockwise. Remove two cover screws and the rear cover.
- See Figure 5. Note position of rear speedometer gasket and remove it. Gently push on rear of speedometer while simultaneously pulling speedometer and front gasket from bracket. Do not remove front gasket from the speedometer.

**INSTALLING SPEEDOMETER IN DOUBLE BRACKET**

**NOTE**

*The tachometer has been mounted in the right side of the double bracket.*

- See Figure 6. Feed wires from speedometer through front of left opening in double bracket. Lubricate the front and rear gaskets with isopropyl alcohol or glass cleaner to ease installation.

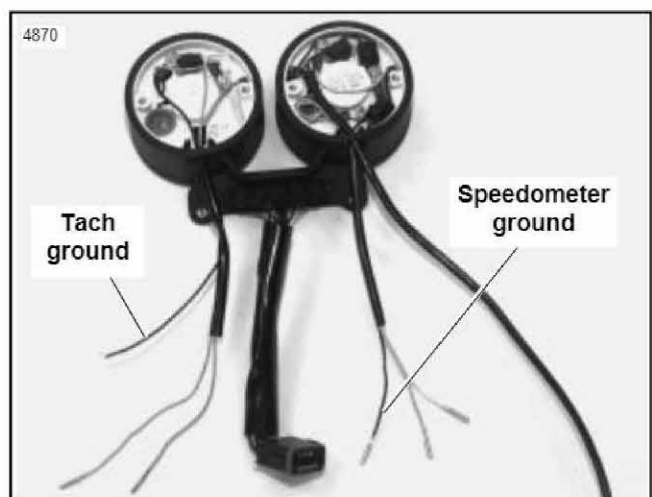

**Figure 6. Speedometer in Double Bracket**

- Insert speedometer in double bracket making certain wire guides are aligned at bottom of bracket.
- Place rear gasket in position and align gasket tabs as shown in Figure 4. Work gasket into space between speedometer and bracket by pushing speedometer against one side of bracket while pushing gasket into position at the opposite side.

- See Figure 4. Check that reset switch is in position as shown and that all wires are positioned so they will not be pinched by rear cover.
- Install rear cover on speedometer, install cover screws and reset switch boot.

### CONNECTING SPEEDOMETER/TACHOMETER GROUND LEADS

- See Figure 6. Cut speedometer black ground lead 1 in. from existing terminal. Strip 3/8 in. insulation from both the wire ends adjacent to the cut. Strip 3/8 in. insulation from tachometer black ground lead.
- See Figure 7. Using the butt connector from the kit connect the ground leads as shown. Refer to "SEALED BUTT CONNECTORS" in the Service Manual for a complete procedure.

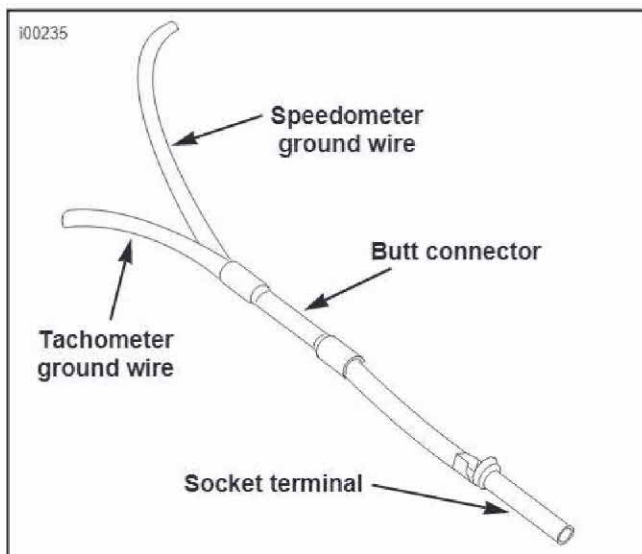

Figure 7. Connecting Tachometer and Speedometer Grounds

### CONNECTING SPEEDOMETER/TACHOMETER LEADS TO 12-PLACE CONNECTOR

- Tape the wires with the socket terminals on their ends together and slide them through the large conduit so the terminals are positioned next to the 12-place connector.
- Remove tape from wires, remove connector seal plugs from cavities 6 and 7 and insert the terminals into the 12-place connector as follows (see applicable Service Manual information for connector closure):

Instrument	Wire Color	Cavity Number
Speedometer	Orange/White	1
Speedometer	White/Green	2
Speedometer	Black	12
Tachometer	Orange/White	6
Tachometer	Pink	7

### INSTALLING INDICATOR LIGHTS ON DUAL BRACKET

- See Figure 8. Place the indicator light bezel and color strip on front of dual bracket. Make certain color strip stays in position on locating pins.

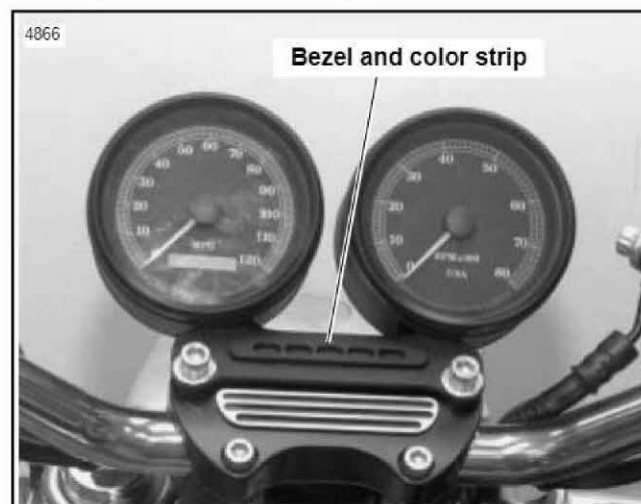

Figure 8. Speedometer/Tachometer Installed

- Install indicator light socket assembly on rear of dual bracket making sure locating pins on bezel enter holes in socket assembly. Install two mounting screws.

### INSTALLING SPEEDOMETER/TACHOMETER

- Place speedometer/tachometer assembly in position and plug in the 12-place connector.
- Return headlamp bracket to its mounted position and secure with two bolts.
- See Figure 8. Mount speedometer/tachometer assembly on handlebar clamp as shown using original fasteners. Tighten screws to 12 - 15 ft-lbs.
- Route speedometer 3-wire harness back to its original position and connect speed sensor 3-place connector.
- Install cable straps to replace any that were removed.
- Refer to applicable Service Manual and install fuel tank using hose clamp in kit. Install seat.

#### **WARNING**

After installing seat, pull upward on front of seat to be sure it is locked in position. If seat is loose, it could shift position during vehicle operation and startle the rider, causing loss of control and personal injury.

### Final Checks and Adjustments

- If necessary, adjust the handlebar to the rider's normal position. Hold the handlebar and loosen rear clamp bolts. Position and adjust handlebars and torque rear screws to 12 - 15 ft-lbs.

#### **CAUTION**

When handlebar installation is complete, the upper and lower clamps have contact with the cast-in boss in front and have a slight gap at the rear.

**⚠ WARNING**

Always connect the positive battery cable first. If the positive cable should contact ground with the negative cable installed, the resulting sparks may cause a battery explosion resulting in personal injury.

2. Connect the battery cables, positive cable first.
3. Turn ignition/light switch to ON. Check that the indicator lights, signal lights and headlamp all function properly.

4. Start the engine, check the tachometer operation and check that the indicator lights are working correctly.
5. If tachometer does not function, see Figure 9 and check that all wiring connections were correctly made.
6. Test ride motorcycle to verify speedometer is functioning properly.

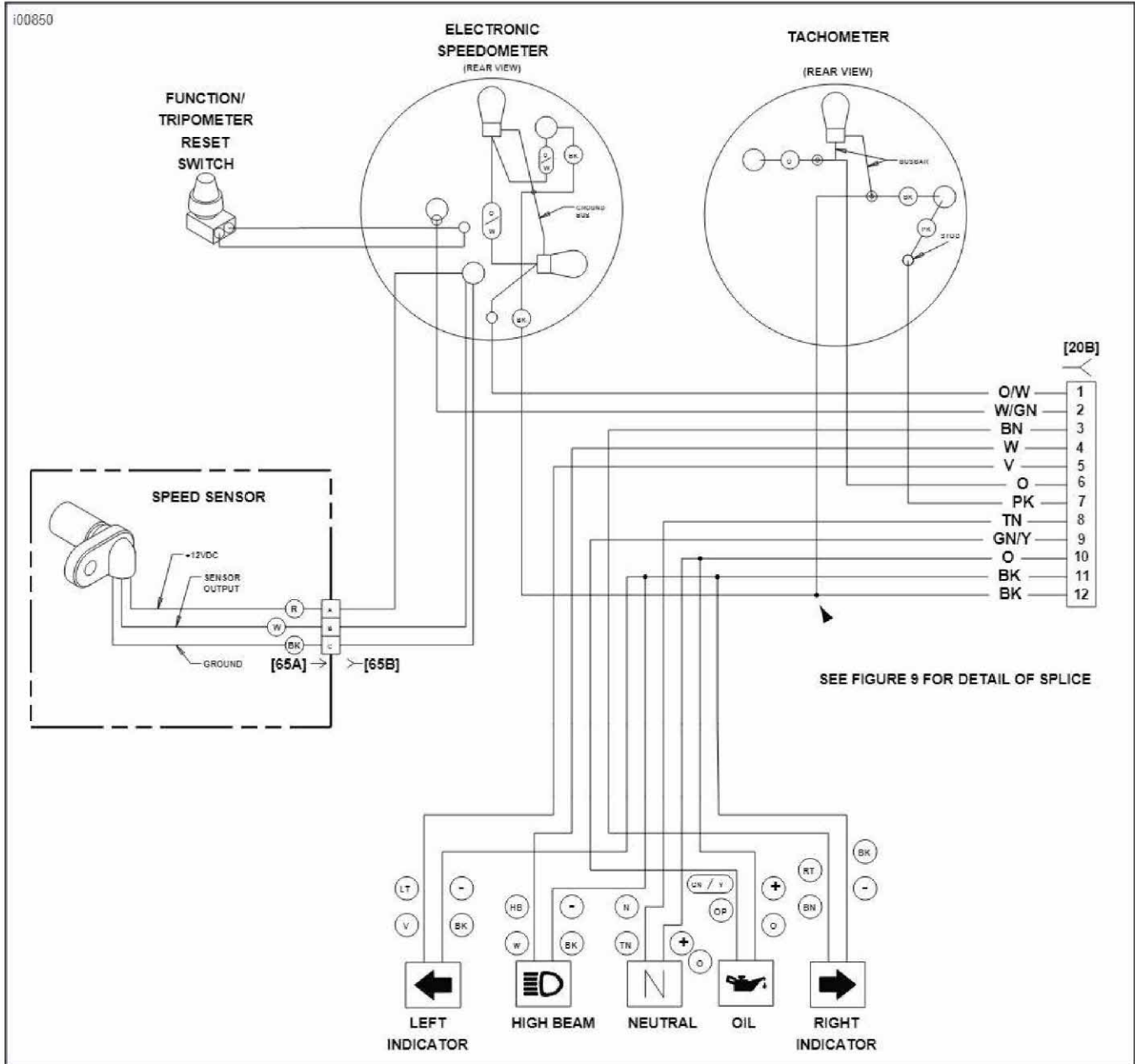

**Figure 9. Wiring Schematic**



# Service Parts

Part No. 67182-95A

Date 11/96

## XLH Tachometer Kit

sp67182A

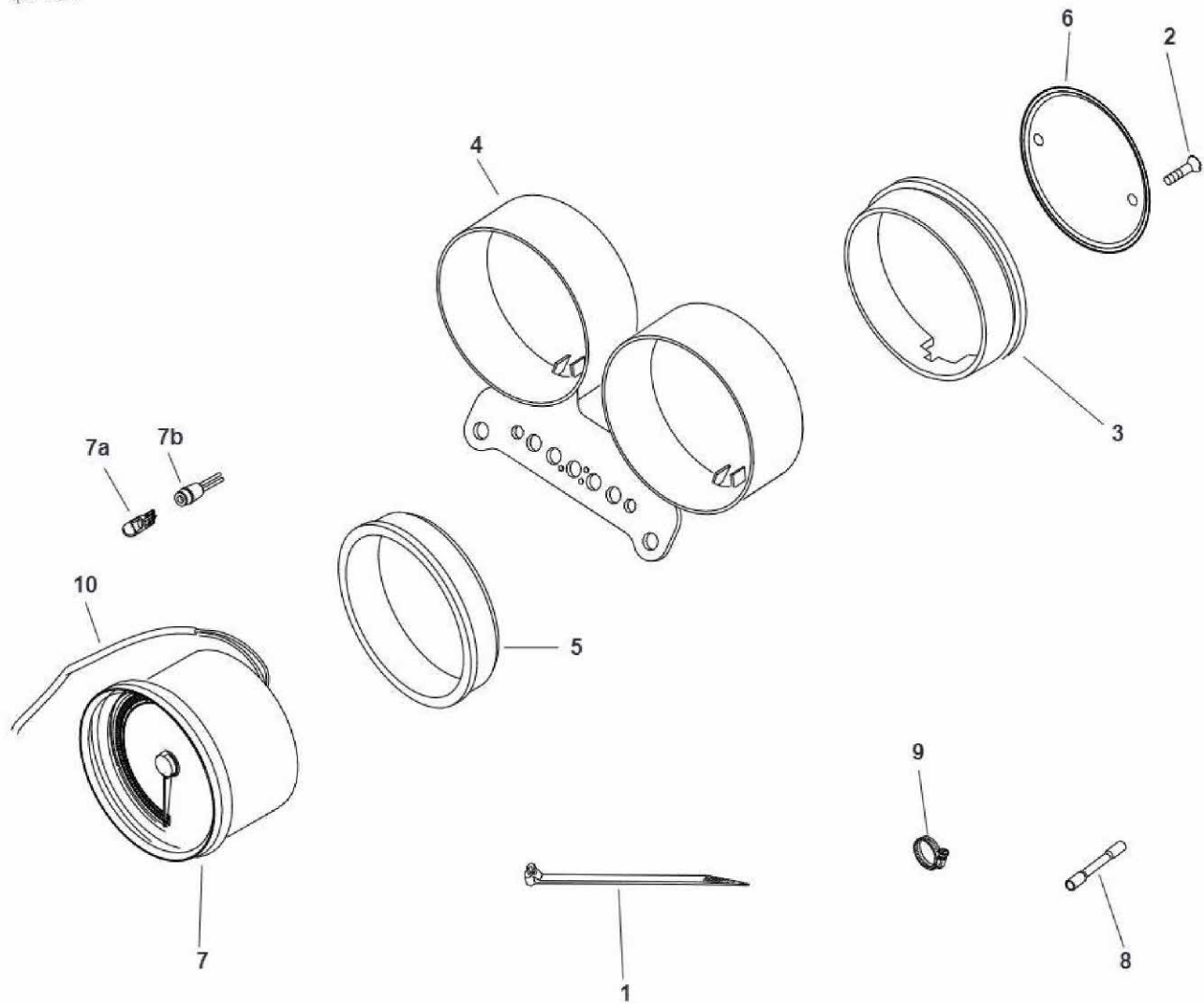

Item	Description	Part No.	Item	Description	Part No.
1	Cable straps (6)	10006	10	1997 wiring harness	
2	Screws, cover (2) #8-32 x 11/64 in.	2361		<b>consists of:</b>	
3	Gasket, rear	67104-95		Amp socket terminals (2)	73191-96
4	Bracket, speedo/tach	67110-95		Ring terminals (3)	72241-94
5	Gasket, front	67121-95		18 gauge wire and conduit	
6	Cover, tach. rear	67319-95	11	1995-1996 wiring harness (not shown)	
7	Tachometer	67321-95		<b>consists of:</b>	
7a	Tachometer light bulb	52441-95		Deutsch socket terminals (2)	72191-94
7b	Tachometer light bulb socket	67191-94		Ring terminals (3)	72241-94
8	Butt splice, blue	70586-93		18 gauge wire and conduit	
9	Hose clamp	9946			