

**PART NUMBER**

71449-67

ORIG. 7-67

**INSTRUCTIONS****HARLEY-DAVIDSON****GENUINE PARTS  
AND ACCESSORIES****STARTER RELAY KIT - SPORTSTER**

Disconnect battery cables and remove battery from motorcycle.

Locate, centerpunch and drill 1/4 in. holes and countersink (82°), for relay mounting bracket in lower flange of battery carrier at rear as shown in Figure 1. Install relay with bracket, screws, lockwashers and nuts as shown. Heads of screws must be flush with surface so they will not damage battery.

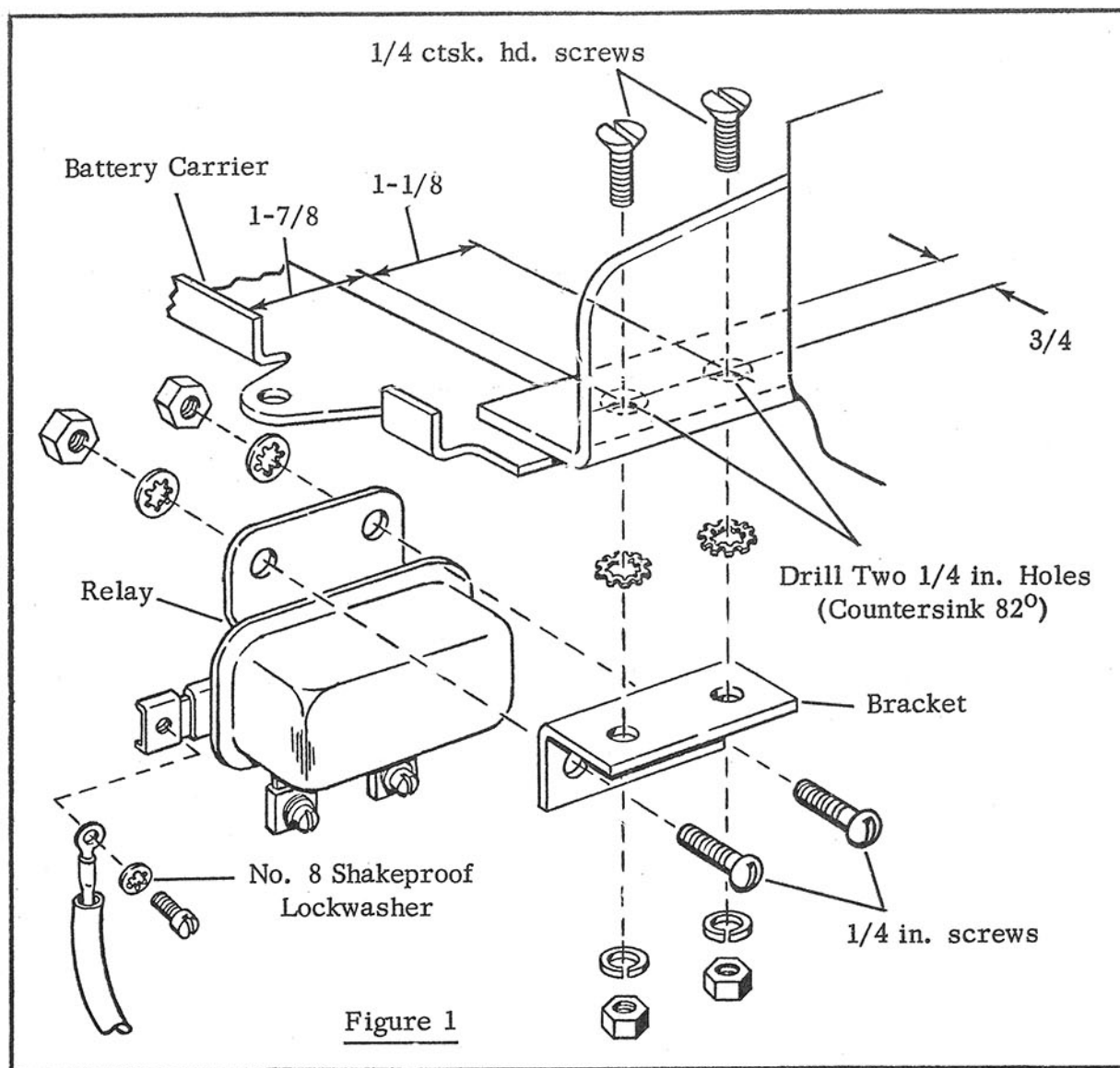

See Wiring Diagram, Figure 2. Remove screw from relay terminal No. 1 and attach red wire with No. 8 lockwasher from kit. Attach black wire from kit to terminal No. 2 of relay with another lockwasher. Disconnect black wire from small center terminal of starter solenoid switch and connect it to No. 3 terminal of relay with remaining lockwasher.

(over)

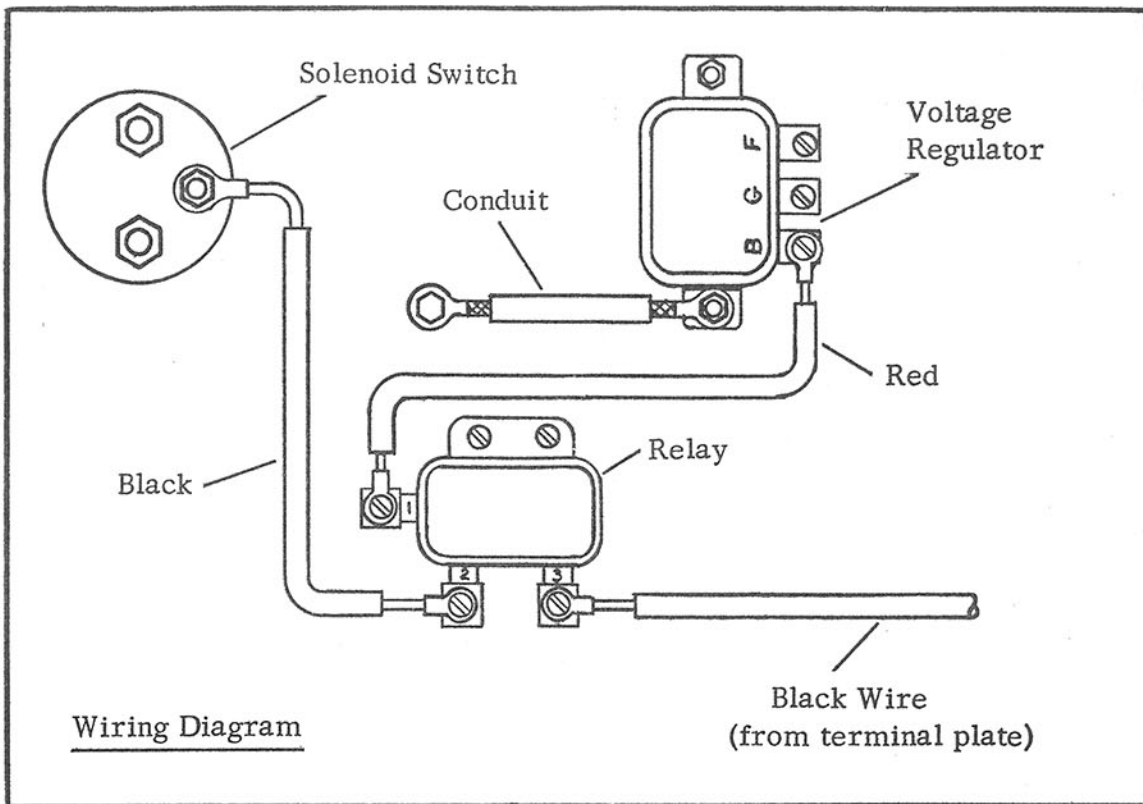

Figure 2

Route red wire from relay terminal No. 1 to terminal "B" of voltage regulator. Route black wire from relay terminal No. 2 to small center terminal of solenoid switch.

Disconnect regulator ground strap, slip conduit from kit over strap and reconnect. This is to prevent strap from grounding on relay cover.

Reinstall battery and reconnect battery cables.