



# INSTRUCTIONS

J06276

2019-01-14

## SPORTSTER REAR SET CONTROL KIT

### GENERAL

#### Solo Seat Only

#### ▲ WARNING

Installation of this kit requires removal of passenger foot pegs, removal of the two-up seat (if so equipped), and installation of a solo seat. Attempting to carry a passenger on a motorcycle equipped with a two-up seat and this kit installed can potentially harm the passenger or adversely affect motorcycle operation, which could result in loss of control and death or serious injury. (02804a)

If the vehicle is currently outfitted as a two-up configuration, the passenger pegs, two-person seat and seat strap have to be removed. To purchase a solo seat for a Sportster, see the Harley-Davidson Genuine Motor Parts and Accessories catalog or contact a Harley-Davidson dealer.

#### Kit Number

50700040

#### Models

For model fitment information, see the P&A retail catalog or the Parts and Accessories section of [www.harley-davidson.com](http://www.harley-davidson.com) (English only).

### Installation Requirements

#### ▲ WARNING

Rider and passenger safety depend upon the correct installation of this kit. Use the appropriate service manual procedures. If the procedure is not within your capabilities or you do not have the correct tools, have a Harley-Davidson dealer perform the installation. Improper installation of this kit could result in death or serious injury. (00333b)

#### NOTE

This instruction sheet references service manual information. A service manual for your motorcycle is required for this installation and is available from a Harley-Davidson Dealer.

883N and 1200T requires the purchase of Right Hand Footpeg (Part No. 51323-08) and Left Hand Footpeg (Part No. 51327-08).

### Kit Contents

See Figure 1, Figure 2 and Table 1.

### INSTALLATION

#### Remove Stock Rider Footrest and Control Assemblies

1. See service manual. Remove stock rider footrest and control assemblies. **Do Not** disassemble rear master cylinder (C).
2. Retain left and right footpegs (except XL883N and 1200T models), as well as the left and right spring washers.
3. Remove wear pegs from footpegs.

#### Remove Exhaust System

1. See service manual. Remove exhaust system, including exhaust mounting bracket on sprocket cover. This will aid in the assembly of the right side control, as well as the new exhaust bracket.

#### Remove Stock Passenger Footrest Assemblies

1. See service manual. Remove left and right passenger footpeg support assemblies. These items will not be reinstalled on vehicle. The brake system may remain in place and does not have to be disconnected.

#### Install Right Footrest and Brake Assembly

1. See Figure 1 and Table 1. Remove bolts which hold rear master cylinder in place. Discard bolts.
2. Install master cylinder yoke (10) to rear master cylinder (C) with previously removed hardware.

#### NOTE

Make sure clevis pin (6) is installed with head closest to the engine.

3. Assemble bell crank (7) to main support bracket (4) with clevis pin (6) and retaining ring (1).
4. Position main support bracket (4) behind rear master cylinder (C), and install hex socket head screws (8) to secure assembly. Tighten to:

Torque: 61–68 N·m (45.0–50.2 ft·lbs) *Hex Socket Head Screw*

5. Secure rear master cylinder (C) to main support bracket (4) with TORX™ button head screws (12). Tighten to:  
Torque: 24.4–30 N·m (18.0–22.1 ft-lbs) *Torx™ Button Head Screw*

**NOTE**

*The angle of the brake pedal can be adjusted by threading the master cylinder yoke (10) clockwise or counter-clockwise.*

6. Attach bell crank (7) to master cylinder yoke (10) with clevis pin (11) and cotter pin (9).

**NOTE**

*When installed, the flat side of the spring washer (B) should face the flat side of the footpeg clevis (2).*

*The spring washer (B) should be installed behind the footpeg.*

7. Assemble stock footpeg (A), spring washer (B) and wear peg mount (15) to footpeg clevis (2). Install mounting pin (6) and retaining ring (1).
8. Install wear peg mount screw (17) through wear peg mount into end of footpeg (A). Tighten to:  
Torque: 8.1–12.2 N·m (71.7–108.0 **in-lbs**) *Wear Peg Mount Screw*
9. Install wear peg (16) into wear peg mount. Tighten to:  
Torque: 8.1–12.2 N·m (71.7–108.0 **in-lbs**) *Wear Peg Mount Screw*

**NOTE**

*To install the exhaust, tie up the brake pedal for clearance.*

10. Install brake rod (14) to brake pedal (3) and bell crank (7). Secure with pins (11) and cotter pins (9).
11. Install exhaust system, using new exhaust mounting bracket (13).
12. Insert footpeg clevis assembly (2) into brake pedal (3) and into main support bracket (4). Insert socket head screw (5) into main support bracket. **Do Not** completely tighten screw (5).
13. Tighten screw (5) holding footpeg clevis (2) to main support bracket (4).  
Torque: 17.6–23 N·m (13.0–17.0 ft-lbs) *Socket Head Screw*
14. Verify clearance between exhaust, brake pedal and brake rod through the full stroke of the brake pedal. If contact is observed, loosen exhaust and adjust until clearance is achieved.

## Install Left Footrest and Shifter Assembly

1. See Figure 2 and Table 1. Position main support bracket (18) onto vehicle and install mounting screws (8) to secure assembly.  
Torque: 61–68 N·m (45.0–50.2 ft-lbs) *Socket Head Screw*

**NOTE**

*When installed, the flat side of the spring washer (B) should face the flat side of the footpeg clevis (2).*

*The spring washer (B) should be installed behind the footpeg.*

2. Assemble stock footpeg (A), spring washer (B) and wear peg mount (22) to footpeg clevis (2). Install mounting pin (6) and retaining ring (1).
3. Install wear peg mount screw (17) through wear peg mount into end of footpeg (A). Tighten to:  
Torque: 8.1–12.2 N·m (71.7–108.0 **in-lbs**) *Wear Peg Mount Screw*
4. Install wear peg (16) into wear peg mount. Tighten to:  
Torque: 8.1–12.2 N·m (71.7–108.0 **in-lbs**) *Wear Peg Mount Screw*
5. Insert wear peg mount assembly (2) into shift lever (19) and into the main support bracket (18). Insert socket head screw (5) into main support bracket. **Do Not** completely tighten screw.
6. Install shift lever (25) onto transmission shift shaft and secure with screw (24). Tighten to:  
Torque: 21.7–27.1 N·m (16.0–20.0 ft-lbs) *Socket Head Screw*
7. Install shifter rod link (20) to shifter lever assembly using screws (21). Tighten to:  
Torque: 13.6–20.4 N·m (120.4–180.5 **in-lbs**) *Shift Lever Screw*

**NOTE**

*The angle of shifter lever (19) can be adjusted by threading the ends of shift rod (20) clockwise or counter-clockwise.*

8. Install shift peg assembly (23) to the shifter lever (19). Tighten to:  
Torque: 10.9–16.3 N·m (96.5–144.3 **in-lbs**) *Shift Peg*
9. Tighten screw (5) to footpeg clevis assembly (2) on main support bracket (18). Tighten to:  
Torque: 17.6–23 N·m (13.0–17.0 ft-lbs) *Socket Head Screw*

# SERVICE PARTS

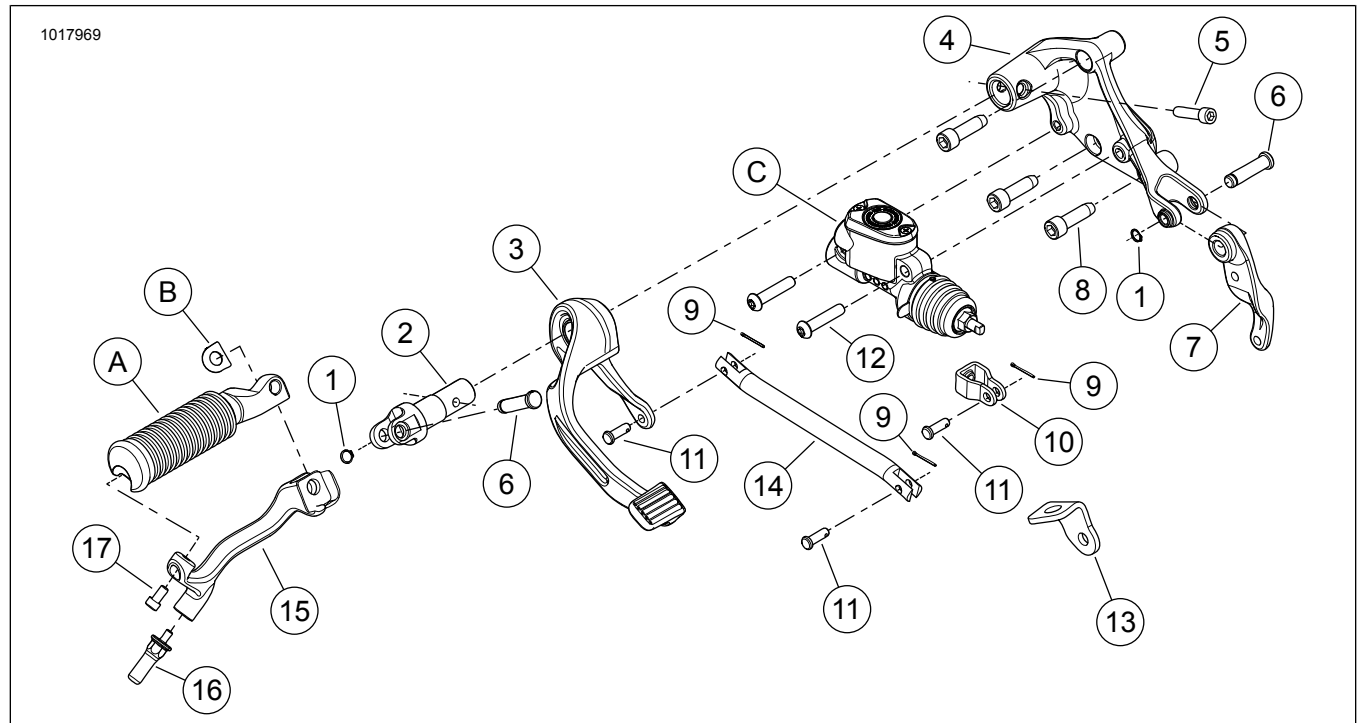

Figure 1. Right Rear Brake Control

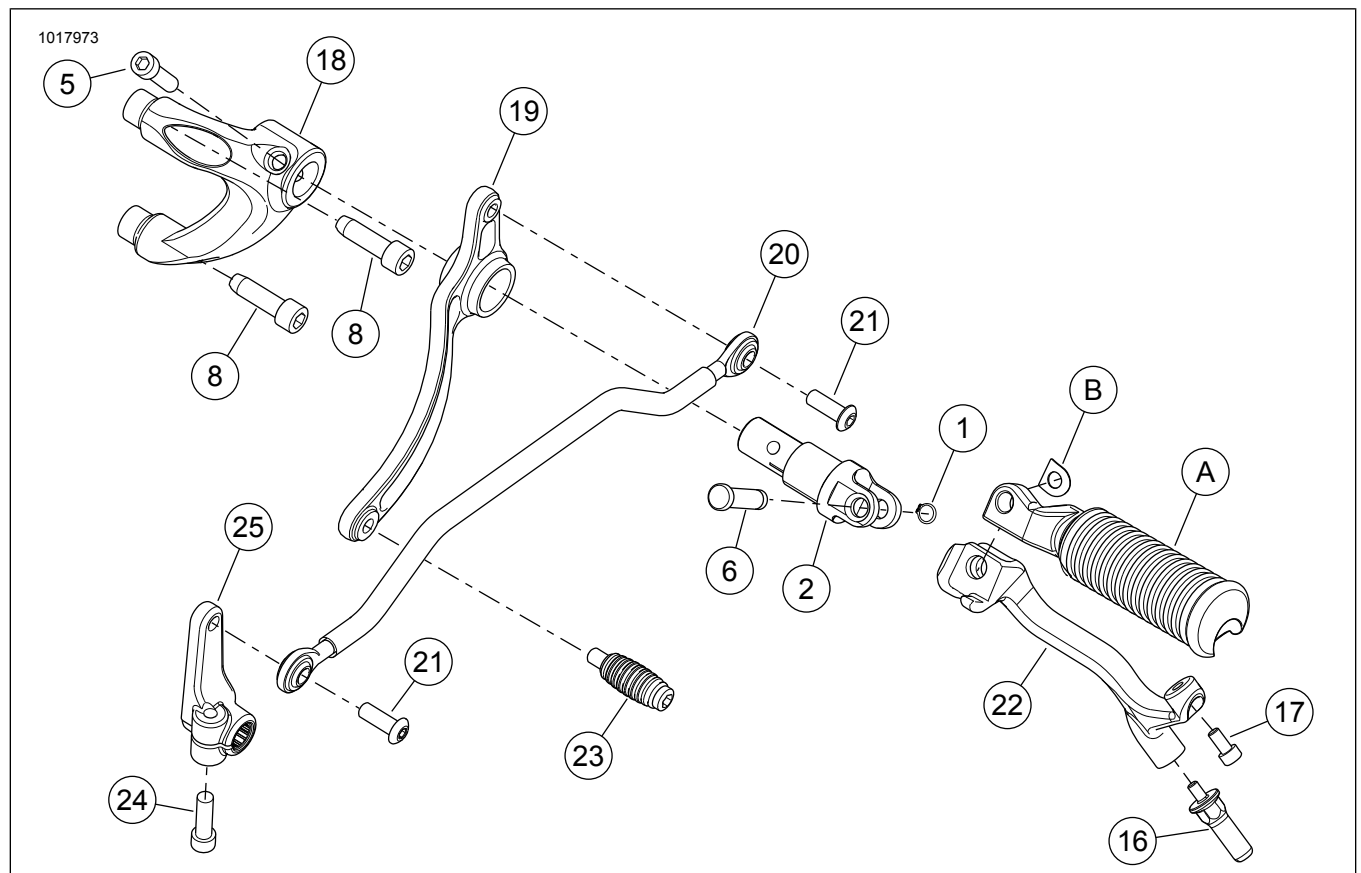

Figure 2. Left Rear Shifter Control

**Table 1.**

<b>Item</b>	<b>Description (Quantity)</b>	<b>Part Number</b>
1	Retaining ring (3)	11304
2	Footpeg clevis (2)	20500774
3	Brake pedal	50600219
4	Main support bracket, right	50700039
5	Screw, hex socket head cap, 3/8-18 x 1-1/4 inch (2)	3162
6	Pin (2)	50700037
7	Bell crank	50700036
8	Screw, hex socket head tapping, 3/8-16 x 1-1/4 inch (5)	3214
9	Cotter pin (3)	515
10	Master cylinder yoke	42813-04
11	Pin (3)	50700038
12	Screw, TORX™ socket button head, 5/16-18 x 1-1/2 inch (2)	8329
13	Exhaust bracket	65500082
14	Brake rod	50700035
15	Wear peg mount, right	50500795
16	Wear peg (2)	33130-07A
17	Screw, M6 x 12 (2)	10200551
18	Main support bracket, left	50700033
19	Shifter lever	33600152
20	Shifter rod link	33600149
21	Screw, hex socket button head, 3/8-18 x 7/8 inch (2)	4359
22	Wear peg mount, left	50500796
23	Shift peg	34672-08
24	Screw, hex socket head cap, 3/8-18 x 1 inch	2708A
25	Shift lever	34724-10

**Table 2.**

<b>Items mentioned in text, but not included in kit:</b>	
A	Stock Footpeg (Separate purchase for XL883N and XL1200T)
B	Spring Washer
C	Stock Master Cylinder