



INSTRUCTIONS

-J05998

2014-10-27

XL FORWARD CONTROL EXTENDED REACH CONVERSION KIT

GENERAL

Kit Number

50700030

Models

For model fitment information, see the P&A Retail Catalog or the Parts and Accessories section of www.harley-davidson.com (English only).

Installation Requirements

Loctite® 243 Medium Strength Threadlocker and Sealant-Blue (Part No. 99642-97) is required for proper installation of this kit.

▲ WARNING

Rider and passenger safety depend upon the correct installation of this kit. Use the appropriate service manual procedures. If the procedure is not within your capabilities or you do not have the correct tools, have a Harley-Davidson dealer perform the installation. Improper installation of this kit could result in death or serious injury. (00333b)

NOTE

This instruction sheet refers service manual information. A service manual for this year/model motorcycle is required for this installation. One is available from a Harley-Davidson dealer.

Kit Contents

See Figure 2, Figure 3 and Table 2.

INSTALLATION

▲ WARNING

To prevent accidental vehicle start-up, which could cause death or serious injury, remove main fuse before proceeding. (00251b)

NOTE

Vehicles equipped with security siren: With security fob present, turn ignition switch ON. After system is disarmed, turn ignition OFF. **IMMEDIATELY** remove the main fuse per the service manual.

Vehicles equipped WITHOUT security siren: See the service manual to remove the main fuse.

This kit does not fit with Harley-Davidson engine guards.

Removal

See service manual for removal of left and right side foot controls. See Table 1 for the parts to save for installation later.

Table 1. Parts to Save from Removal Process

Left Side	Right Side
• Footpeg	• Footpeg
• Spring washer	• Spring washer
• Footpeg clevis	• Clevis screw
• Clevis screw	• Retaining ring
• Retaining ring	• Master cylinder pin and clip
• Shift lever	
• Screws	

Install Forward Control Brake Pedal and Footrest Assemblies

1. See Figure 3. Obtain new support bracket (10) and new brake pedal assembly (7) from kit.

NOTE

Assemble brake pedal and footpeg clevis onto footrest support bracket (described in the next step) before mounting support bracket to frame. This allows easier installation of the footrest mount clevis retaining ring (installed to grooved end of footrest mount clevis).

2. Slide the brake pedal (7) onto footrest mount clevis (11). Slide clevis into support bracket. Align hole in the clevis with hole in support bracket. Install original screw. Tighten the screw to 17.6–23 N·m (13–17 ft-lbs).
3. Install the original clevis retaining ring to the groove at the end of the footpeg clevis.
4. Obtain the two new support screws (4) from kit.
5. See the service manual. Position the J-clip against the frame aligning the mounting holes. Mount the footrest/brake pedal support bracket and J-clip to frame using the new screws. Tighten the screws to 61.1–67.9 N·m (45–50 ft-lbs)
6. Obtain the brake rod from kit. Insert one end into the master cylinder collar. Rotate the collar to align the hole with the brake rod hole.
7. Secure the front of the brake to the brake pedal with the supplied pin. Secure the pin in place with the locking ring.
8. See Figure 2. Obtain the saved footpeg, spring washer, footpeg clevis pin and footpeg clevis retaining ring from kit.



9. Install footpeg on clevis with spring washer. Verify that spring washer is positioned inside clevis with the square edge toward the inside. Align holes. Push clevis pin from top down through hole in clevis. Secure clevis pin using the new retaining ring.

Install Forward Control Shift Lever Assembly

1. See Figure 2. Mount support bracket (3) to frame using screws (4). Tighten to 61.1–67.9 N·m (45–50 ft-lbs).
2. Slide shift pedal onto clevis. Mount clevis on pedal support bracket. Align hole in clevis with hole in support bracket. Secure using screws. Tighten screw to 17.6–23 N·m (13–17 ft-lbs).
3. Install retaining ring to the relief at the end of the clevis to further secure it in place.
4. Thread screw in far end of the shift rod (2) and into shifter arm. Tighten to 13.6–20.3 N·m (10–15 ft-lbs).
5. Thread screw in opposite end of shift rod (2) on the inboard side of the shift pedal. Tighten to 13.6–20.3 N·m (10–15 ft-lbs).
6. Install shifter peg into shift lever. Tighten securely.
7. See Figure 3. Obtain the saved footpeg, spring washer, footpeg clevis pin and footpeg clevis retaining ring from kit.
8. Install footpeg on clevis with spring washer. Verify that spring washer is positioned inside clevis with the square edge toward the inside. Align holes. Push clevis pin from top down through hole in clevis. Secure clevis pin using the new retaining ring.

Adjusting Shift Pedal

If the gears do not engage fully or the toe shifter travel is incorrect, the shift linkage must be adjusted.

See Figure 1. Adjust the shift rod until the shift pedal is at 45 degrees as described.

1. Remove screw (1) securing the ball joint (2) to shift pedal (5).

2. Turn ball joint or shift rod (4) to adjust rod length. Temporarily attach ball joint to shift pedal and check pedal angle. Make sure that an equal number of threads are visible on both ends of shift rod.
3. When pedal angle is at 45 degrees, install screw (1). Tighten to 13.6–20.3 N·m (10–15 ft-lbs).
4. Holding shift rod (4) so that it does not turn, securely tighten locknuts (3) on each end.

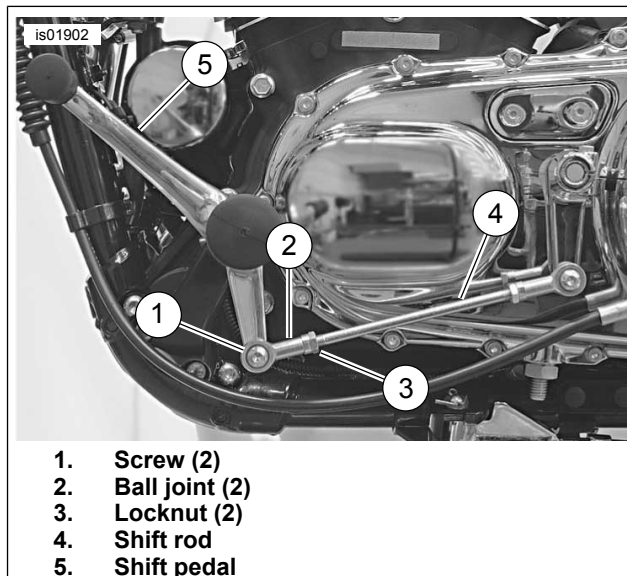

Figure 1. Adjusting Shift Pedal

Wear Peg Replacement

NOTE

Refer to the service manual for the wear peg orientation.

1. Remove existing wear peg from footpeg.
2. Apply 2 or 3 drops of Loctite 243 Threadlocker and Sealant (Blue) to the threads of the new wear peg and install to the footpeg.
3. Tighten wear peg (5) to 19–21.7 N·m (14–16 ft-lbs).

SERVICE PARTS

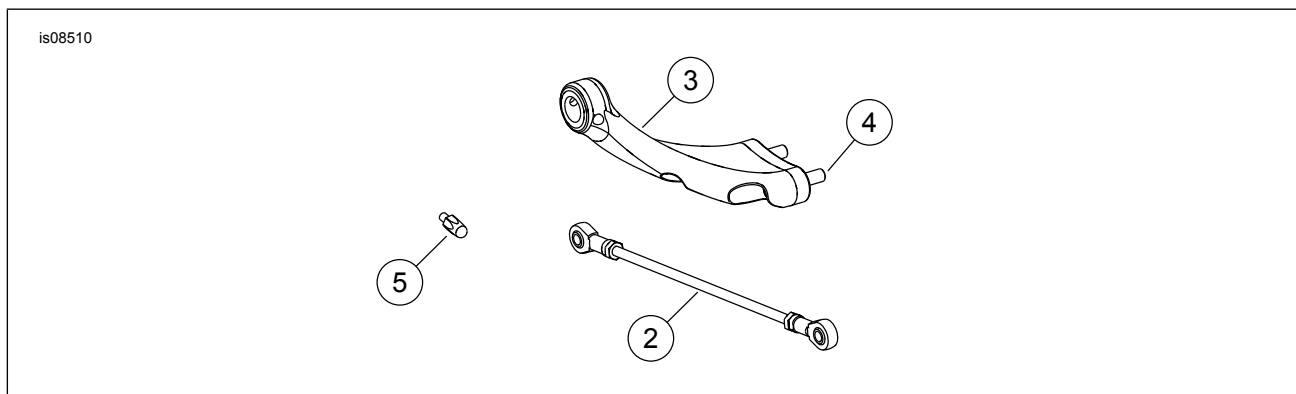

Figure 2. Service Parts: Forward Control Left (Shift) Side

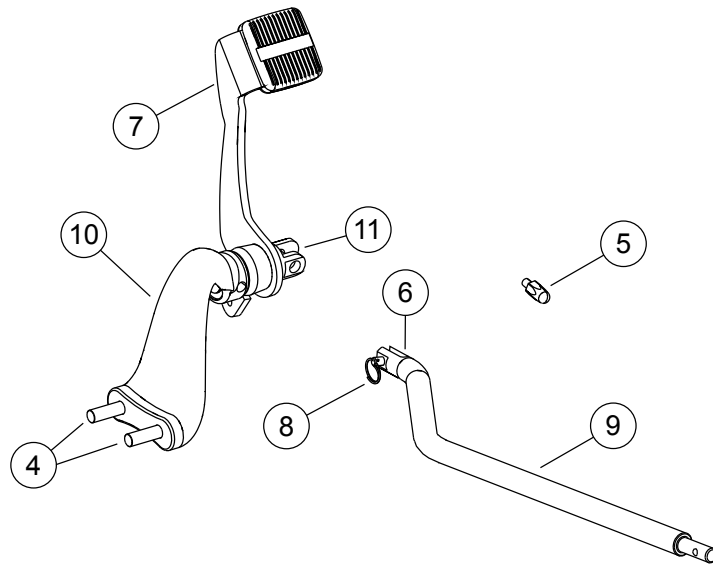

Figure 3. Service Parts: Forward Control Right (Brake) Side

Table 2. Service Parts

Item	Description (Quantity)	Part Number
1	Lever assembly	42542-06
2	Shifter rod link	Not Sold Separately
3	Footpeg mount, left	Not Sold Separately
4	Screw (4)	3214
5	Wear peg (2)	33129-06
6	Clevis pin	42460-80B
7	Brake pedal pad	42532-06
8	Cotter	51938-04
9	Brake rod	Not Sold Separately
10	Footpeg mount, right	Not Sold Separately
11	Clevis	Not Sold Separately