



INSTRUCTIONS

-J05877

2014-02-06

XL FORWARD CONTROL REDUCED REACH CONVERSION KIT

GENERAL

Kit Number

50700026

Models

For model fitment information, see the P&A retail catalog or the Parts and Accessories section of www.harley-davidson.com (English only).

Installation Requirements

Loctite® 243 Medium Strength Threadlocker and Sealant - Blue (Part No. 99642-97) is required for proper installation of this kit.

▲ WARNING

Rider and passenger safety depend upon the correct installation of this kit. Use the appropriate service manual procedures. If the procedure is not within your capabilities or you do not have the correct tools, have a Harley-Davidson dealer perform the installation. Improper installation of this kit could result in death or serious injury. (00333b)

NOTE

This instruction sheet refers to service manual information. A service manual for this year/model motorcycle is required for this installation. One is available from a Harley-Davidson dealer.

Kit Contents

See Figure 3 and Table 1.

PREPARATION

▲ WARNING

To prevent accidental vehicle start-up, which could cause death or serious injury, remove main fuse before proceeding. (00251b)

NOTE

- **Vehicles equipped with security siren:** With security fob present, turn ignition switch ON. After system is disarmed, turn ignition switch OFF. **IMMEDIATELY** remove the main fuse per the service manual.
- **Vehicles WITHOUT security siren:** See the service manual to remove the main fuse.

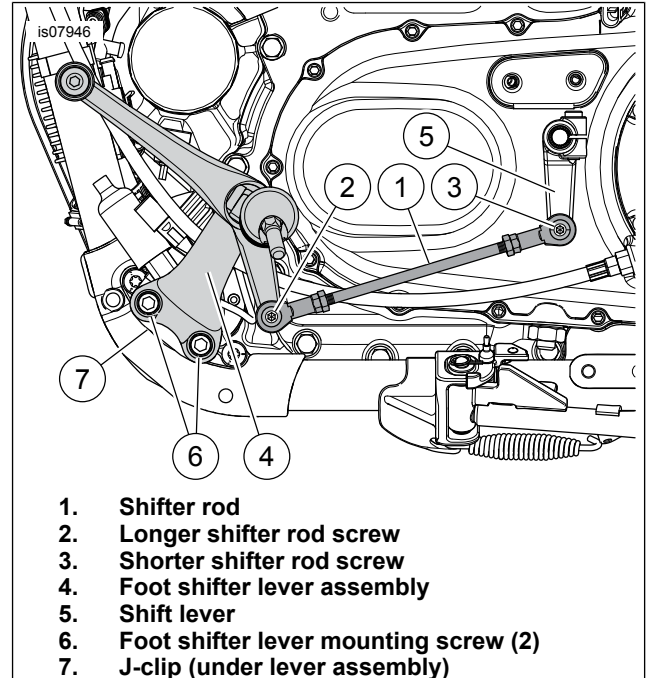

Figure 1. Forward Control Shifter Linkage (XL)

FOOT SHIFTER LEVER (left side)

Removal

1. See Figure 1. Remove the original equipment (OE) shifter rod screws (2, 3) and shifter rod (1) from the foot shifter lever assembly (4) and shift lever (5). Save the screws. Discard the shifter rod.
2. Remove and discard two screws (6). Remove the foot shifter lever assembly (4) and J-clip (7) from the vehicle frame. Save for installation.

Installation

NOTE

The reduced reach bracket mounts to the vehicle with the tapped holes to the rear.

1. See Figure 3. Get a reduced reach bracket (3), two thick spacers (4), two 57.2 mm (2.25 in) long screws (7) and two larger washers (8) from the kit.
2. Install a washer onto each screw. Insert the screws with washers through the clearance holes in the reduced reach bracket (3) and spacers (4), and the J-clip (E) removed earlier.
3. Position the bracket/spacer/J-clip assembly at the original location of the foot shifter lever assembly (D). Install the assembly to the vehicle frame with the screws and washers. Tighten to 61–68 N·m (45–50 ft·lbs).

4. Install the foot shifter lever assembly (D) to the reduced reach bracket (3) with two screws (9) from the kit. Tighten to 61–68 N·m (45–50 ft-lbs).
5. Get the reduced reach shift linkage assembly (1) from the kit. Get the OE shifter rod screws (A, B) removed earlier. Clean all thread locking material from the screw threads. Apply two drops of Loctite 243 - Blue to the **clean** screw threads.
6. Position the linkage assembly as shown, with the solid end at the shift lever (C) threaded hole. Insert the shorter screw through the hole in the linkage. Thread the screw partially into the shift lever hole.
7. Position the adjustable end of the linkage assembly at the foot shifter lever assembly. Insert the longer screw through the hole in the linkage. Thread the screw partially into the foot shifter lever hole.

NOTE

After all shifter components are installed, move shifter through entire range of motion. Check for interference with other components. Adjust shift rod length for clearance to primary case.

8. Tighten the linkage attaching screws to 13.6–20.4 N·m (120–180 in-lbs).
9. Adjust the foot shift pedal position as needed per the service manual.

REAR BRAKE PEDAL (right side)

Removal

1. Remove the brake rod per the service manual. Save the attaching hardware (2, 3) from the master cylinder end. Discard the brake rod (1).
2. Remove and discard two screws (6). **Non-ABS models:** Remove and save the brake pedal support bracket assembly (5) and J-clip (7). **ABS models:** Remove and save the brake pedal support bracket assembly (5). The ABS brake lines and bracket (8) remain in position.

Installation

NOTE

The reduced reach bracket mounts to the vehicle with the tapped holes to the rear.

1. See Figure 3. Get a reduced reach bracket (3), two thin spacers (5), two 44.4 mm (1.75 in) long screws (6) and two larger washers (8) from the kit.
2. Install a washer onto each screw. Insert the screws with washers through the clearance holes in the reduced reach bracket (3) and spacers (5), and the J-clip or ABS line bracket (E) removed earlier.

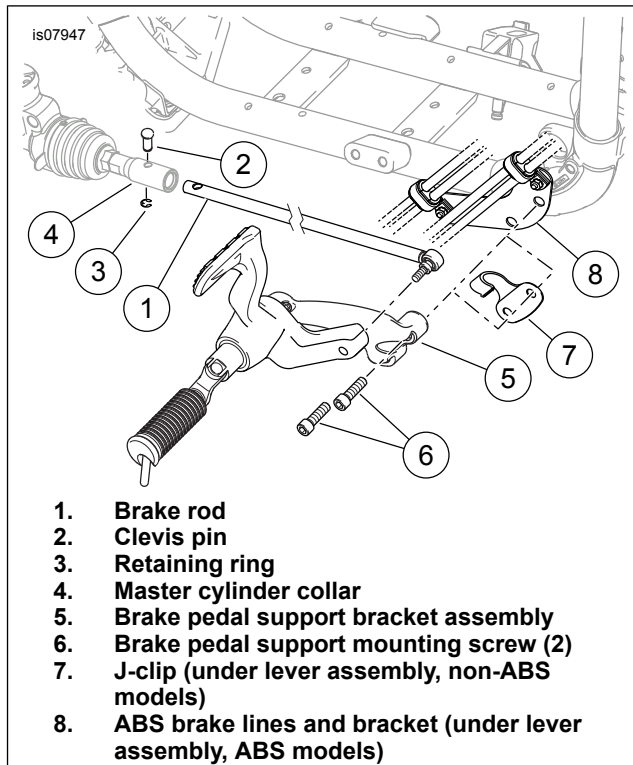

Figure 2. Forward Control Rear Brake Linkage (XL Models)

3. Position the brake and spacer assembly at the original location of the brake pedal support bracket assembly (F). Install the bracket assembly to the vehicle frame with the screws and washers. Tighten to 61–68 N·m (45–50 ft-lbs).
4. Install the brake pedal support bracket assembly (F) to the reduced reach bracket (3) with two screws (9) from the kit. Tighten to 61–68 N·m (45–50 ft-lbs).
5. Get the reduced reach brake rod (2) from the kit. Get the OE clevis pin and retaining ring removed earlier. Insert the brake rod end into the master cylinder collar. Secure with the clevis pin and retaining ring.
6. Get the screw (10), washer (11), plastic bushing (12) and spacer (13) from the kit. At the forward end of the brake rod,
 - a. Press fit the plastic bushing into the rod, flush with each side.
 - b. Insert the spacer through the plastic bushing.
 - c. Insert the screw through the spacer.
7. Apply two drops of Loctite 243 - Blue to the **clean** screw threads.
8. Thread the screw into the brake pedal. Tighten to 13.6–20.4 N·m (120–180 in-lbs).

COMPLETION

NOTE

*Verify that the ignition key switch is in the OFF position **before** installing the main fuse.*

1. See the service manual to install the main fuse.

SERVICE PARTS

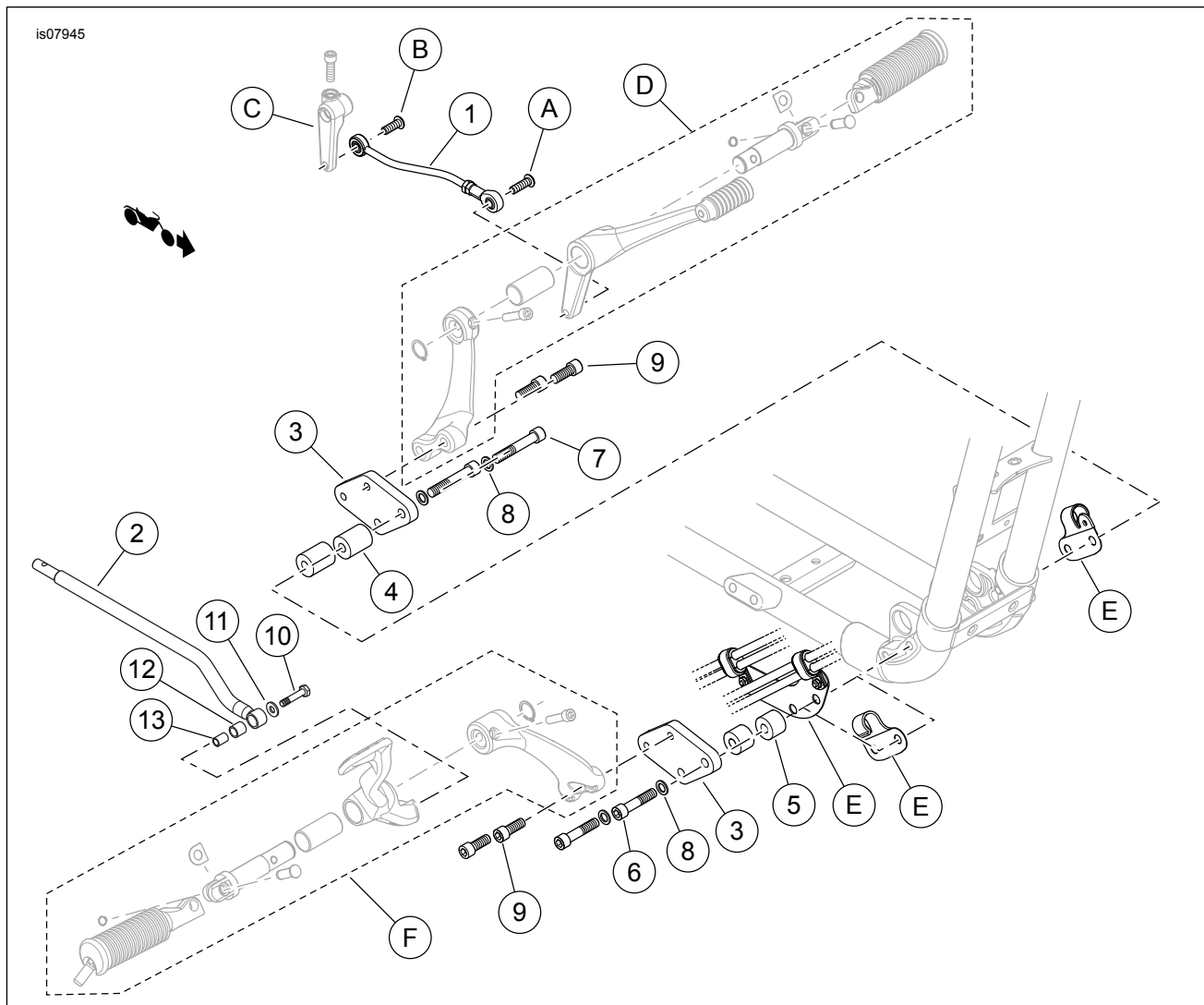

Figure 3. Service Parts, XL Forward Control Reduced Reach Conversion Kit

SERVICE PARTS

Table 1. Service Parts

Item	Description (Quantity)	Part Number
1	Shift linkage assembly, reduced reach	Not sold separately
2	Brake rod, reduced reach	Not sold separately
3	Bracket, forward control, reduced reach (2)	Not sold separately
4	Spacer, 31.8 mm (1.25 in) thick (2)	Not sold separately
5	Spacer, 19 mm (0.75 in) thick (2)	Not sold separately
6	Screw, hex socket head, 3/8-16 x 44.4 mm (1.75 in) long (2)	4310
7	Screw, hex socket head, 3/8-16 x 57.2 mm (2.25 in) long (2)	4201
8	Flat washer, 9.5 mm (3/8 in) ID (4)	Not sold separately
9	Screw, hex socket head, 3/8-16 x 25.4 mm (1.0 in) long (2)	861A
10	Screw, hex socket head, 1/4-28 x 31.8 mm (1.25 in) long, Grade 8	10200296
11	Flat washer, 6.4 mm (1/4 in) ID (4)	6703
12	Bushing, plastic	11000113
13	Bushing insert, stainless steel	12400080
Items mentioned in text, but not included in kit:		
A	Original equipment (OE) shifter rod to foot shifter lever screw	
B	OE shifter rod to shift lever screw	
C	OE shift lever	
D	OE Foot shifter lever assembly	
E	J-clip (shifter side) J-clip (brake pedal side, without ABS) Brake line bracket assembly (brake pedal side, with ABS)	
F	Brake pedal support bracket assembly	