



INSTRUCTIONS

-J05783

2013-05-28

XL FORWARD CONTROL KIT

GENERAL

Kit Number

50700020, 50700021

Models

For model fitment information, see the P&A Retail Catalog or the Parts and Accessories section of www.harley-davidson.com (English only).

Additional Parts Required

This kit requires the use of Loctite® 243 Threadlocker and Sealant - blue (Part Number 99642-97) which is available from a Harley-Davidson dealer.

▲ WARNING

Rider and passenger safety depend upon the correct installation of this kit. Use the appropriate service manual procedures. If the procedure is not within your capabilities or you do not have the correct tools, have a Harley-Davidson dealer perform the installation. Improper installation of this kit could result in death or serious injury. (00333b)

NOTE

This instruction sheet references Service Manual information. A Service Manual for your model motorcycle is required for this installation and is available from a Harley-Davidson dealer.

Kit Contents

See Figure 5, Figure 6 and Table 1.

INSTALLATION

Remove Stock Shift Lever and Footrest Assembly

1. See Figure 1. Loosen the shift lever retaining screw (2) securing the shift lever (1) to the shifter shaft. Slide the shift lever off the splined shaft. Remove shifter peg from lever and save for installation. Discard shift lever.
2. Remove the two socket head screws (4) securing the footrest bracket (3) to the frame and remove footrest. Discard screws.
3. See Figure 5. Obtain two hole plugs (1) from kit and firmly press plugs into frame screw holes remaining from footrest removal.
4. See Figure 2. Remove the retaining ring (1) from the clevis to free the footrest clevis pin (4). Remove the clevis pin and footrest (3) from the footrest support. Save footrest, clevis pin and spring washer (2) for installation. Discard retaining ring and footrest bracket.

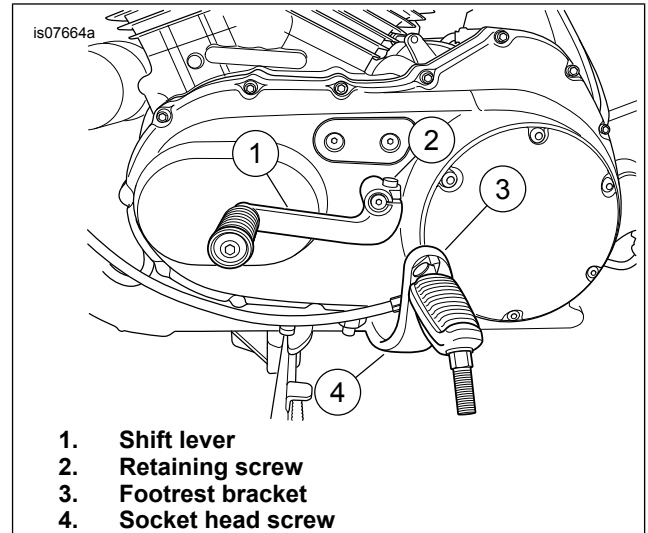

Figure 1. Remove Shift Lever and Footrest

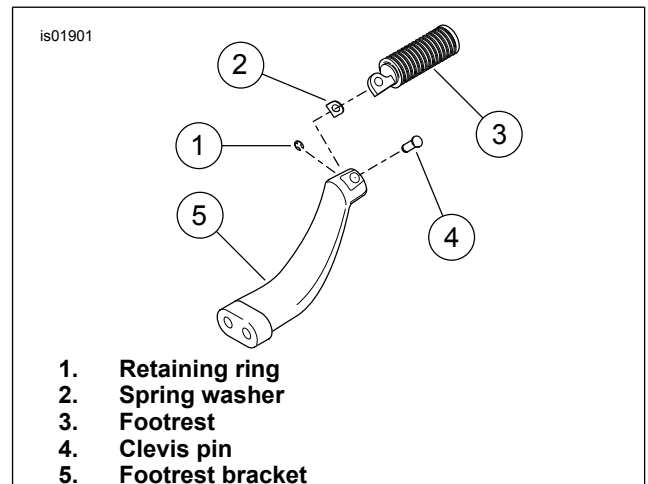

Figure 2. Remove Left Footrest from Support

Remove Stock Brake Pedal and Footrest Assembly

1. See Figure 3. At the right footrest, remove the retaining ring (1), clevis pin (2), footrest (3) and spring washer (4). Discard retaining ring (1) but save footrest, clevis pin and spring washer for installation.
2. Remove brake rod (5) from brake pedal and master cylinder push rod collar. Discard brake rod.
3. Remove the two screws (6) and right footrest/brake pedal support bracket with attached brake assembly from frame. Discard footrest support bracket and entire brake pedal assembly.
4. See Figure 6. Obtain hole plugs (1) and install in holes left from support bracket removal.

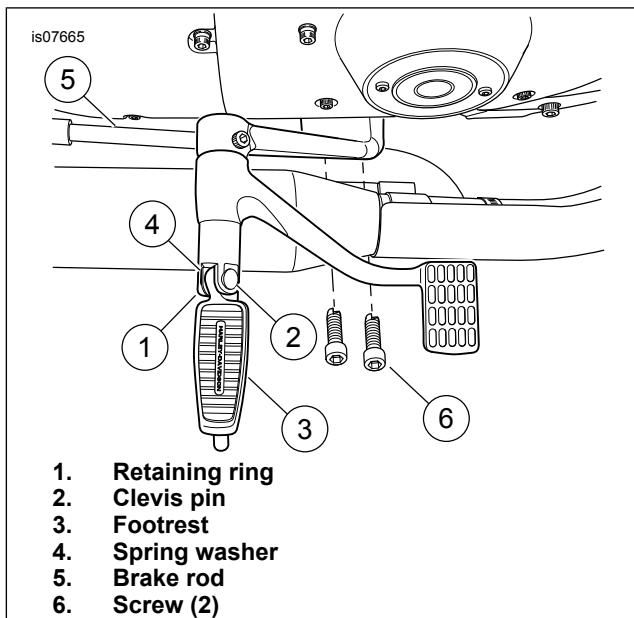

Figure 3. Remove Footrest Support and Brake Pedal

Install Forward Control Brake Pedal and Footrest Assemblies

NOTE

It is easier to install the following components if the exhaust system is removed. Refer to the applicable Service Manual for removal/installation procedures.

1. See Figure 6. At the lower front of the right frame downtube, remove the two screws securing the J-clip (B) to the frame. Discard the screws but save J-clip for installation.

NOTE

Assemble the brake pedal and footpeg clevis onto the footrest support bracket (as described in the next step) prior to mounting the support bracket to the frame. This will allow easier installation of the footrest mount clevis retaining ring (installed to grooved end of footrest mount clevis).

2. Obtain the new footrest/brake pedal support bracket (7), new brake pedal assembly (6), footrest mount clevis (9), screw (5) and footrest mount clevis retaining ring (15) from kit.
3. Slide the brake pedal (6) onto footrest mount clevis (9) then slide clevis into footrest/brake pedal support bracket (7). Align hole in the clevis with hole in the support bracket and install screw (5). Tighten the screw to 17.6–23 N·m (13–17 ft-lbs).
4. Install the footrest mount clevis retaining ring (15) to the groove at the end of the footpeg clevis.
5. Obtain the two new footrest/brake pedal support screws (2) from kit.
6. Position the J-clip (from Step 1) against the frame aligning the mounting holes. Mount the footrest/brake pedal support bracket (7) and J-clip to frame using the new screws (2). Tighten the bracket to 61.1–67.9 N·m (45–50 ft-lbs).

7. Obtain the brake rod (13) from kit and insert one end into the master cylinder collar. Secure with brake pedal pushrod pin and E-style clip.
8. Apply two drops of Loctite 243 (blue) to ball stud screw.
9. Thread the ball stud screw into the brake pedal assembly (6). Tighten to 13.6–20.4 N·m (120–180 in-lbs).
10. See Figure 6. Obtain the saved footpeg, spring washer, footpeg clevis pin and footpeg clevis retaining ring (20) from kit.
11. Install footpeg on clevis with spring washer. Make sure spring washer is positioned inside clevis (9) with the square edge toward the inside. Align holes and push clevis pin from top down through hole in clevis. Secure clevis pin using the new retaining ring (20).

Install Forward Control Shift Lever Assembly

1. See Figure 5. Obtain shift link arm (11) and screw (16) from kit. Orient shift link arm pointing straight down and slide onto shift shaft (exiting engine sidecover). Install screw (16) and tighten to 22–27 N·m (16–20 ft-lbs).
2. Mount footrest/shift pedal support bracket (7) to frame using screws (2). Tighten to 61.1–67.9 N·m (45–50 ft-lbs).
3. Slide shift pedal (12) onto clevis (10). Mount clevis on footrest/shift pedal support bracket (8). Align hole in clevis with hole in support bracket and secure using screw (5). Tighten screw to 17.6–23 N·m (13–17 ft-lbs).
4. Install retaining ring (15) to the relief at the end of the clevis (10) to further secure it in place.
5. Thread screw (3) in far end of the shift rod (14) and into shifter arm (11). Tighten to 13.6–20.3 N·m (10–15 ft-lbs).
6. Thread screw (4) in opposite end of shift rod (14) into shift pedal (12). Tighten to 13.6–20.3 N·m (10–15 ft-lbs).
7. Install shifter peg into new shift lever. Tighten securely.
8. See Figure 5. Obtain the saved footpeg, spring washer, footpeg clevis pin and footpeg clevis retaining ring (20) from kit.
9. Install footpeg on clevis (10) with spring washer. Make sure spring washer is positioned inside clevis with the square edge toward the inside. Align holes and push clevis pin from top down through hole in clevis. Secure clevis pin using the new retaining ring (20).

Adjusting Shift Pedal

If the gears do not engage fully or the toe shifter travel is incorrect, the shift linkage must be adjusted. See Figure 4. Adjust the shift rod until the shift pedal is at 45 degrees as described.

1. Remove screw (1) securing the ball joint (2) to shift pedal (5).

2. Turn ball joint or shift rod (4) to adjust rod length. Temporarily attach ball joint to shift pedal and check pedal angle. Make sure an equal number of threads are visible on both ends of shift rod.
3. When pedal angle is at 45 degrees, install screw (1). Tighten to 13.6–20.3 N·m (10–15 ft-lbs).
4. Holding shift rod (4) so that it does not turn, tighten locknuts (3) on each end securely.

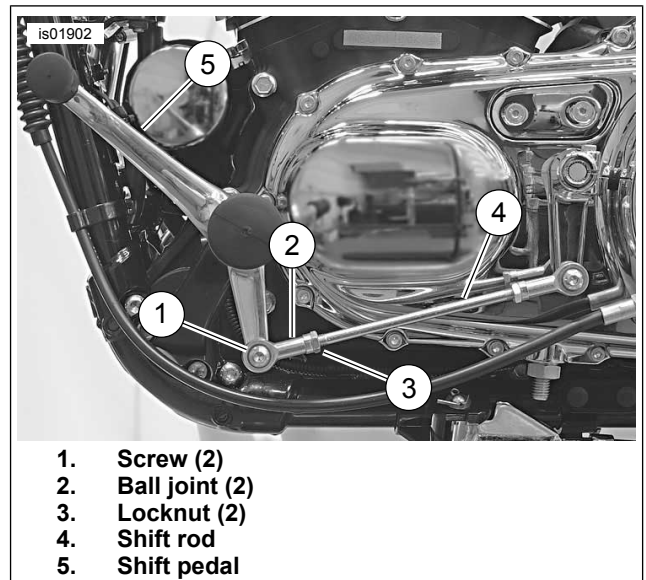

Figure 4. Adjusting Shift Pedal

SERVICE PARTS

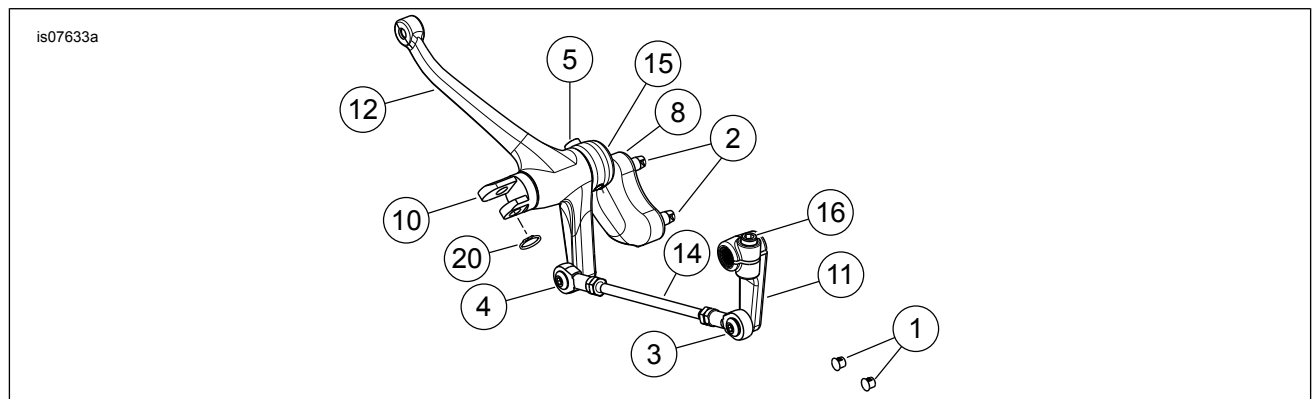

Figure 5. Service Parts: Forward Control Left (Shift) Side

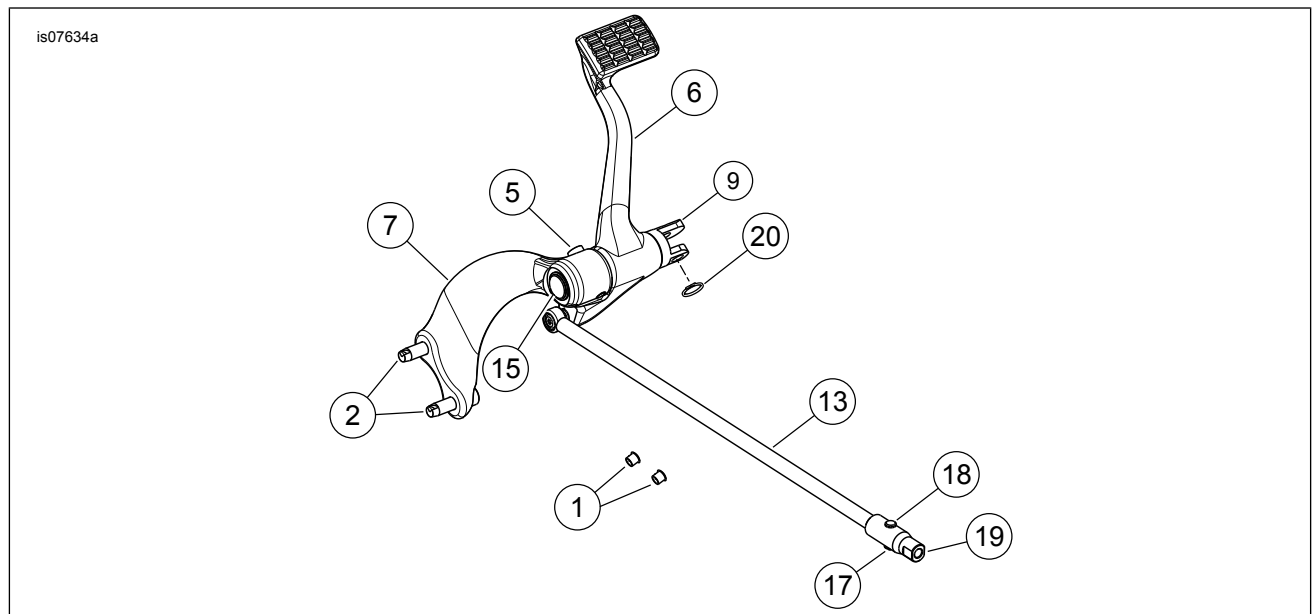

Figure 6. Service Parts: Forward Control Right (Brake) Side

Table 1. Service Parts Table

Item	Description (Quantity)	Part Number
1	Plug, hole (4)	90493-83
2	Screw, 3/8-16 x 1-1/4 inch (4)	3214
3	Screw, 5/16-18 x 7/8 inch	4359
4	Screw, hex button (lock) 5/16-18 x 1 inch	4016
5	Screw, hex socket 5/16-18 x 1-1/4 inch (2)	3162

Table 1. Service Parts Table

Item	Description (Quantity)	Part Number
6	Assembly, brake pedal, chrome	50600111
	Assembly, brake pedal, black	50600025
7	Bracket, right rider footpeg support, black	42652-04
8	Bracket, left rider footpeg support, black	42651-04
9	Clevis footpeg, right	51731-10
10	Clevis footpeg, left	51730-10
11	Lever, shift shaft arm, black	34724-10
	Lever, shift shaft arm, chrome	34670-06
12	Assembly, shift lever, chrome	33600043
	Assembly, shift lever, black	34723-10
13	Assembly, brake rod, black	50600092
	Assembly, brake rod, chrome	50600123
14	Assembly, shift rod link, black	34663-10
	Assembly, shift rod link, chrome	33600049
15	Ring, footrest mount clevis retaining (2)	11390
16	Screw	2708A
17	Clip, E-style	12600080
18	Brake pedal pushrod pin	50600101
19	Rear master cylinder pushrod collar, chrome	41700259
20	Retaining ring	11304
Items mentioned in text, but not included in kit:		
A	Stock footrest	
B	Stock J-clip	