



INSTRUCTIONS

-J04708

2008-02-15

XR1200 FRONT CALIPER PISTON KIT

GENERAL

Kit Number

21965-08

Models

For model fitment information, please see the P&A Retail Catalog or the Parts and Accessories section of www.harley-davidson.com (English only).

Additional Parts Required

Separate purchase and installation of additional parts or accessories may be required for proper installation of this kit on your model motorcycle. Please see the P&A Retail Catalog or the Parts and Accessories section of www.harley-davidson.com (English only) for a list of required parts or accessories for your model.

▲ WARNING

Rider and passenger safety depend upon the correct installation of this kit. Use the appropriate service manual procedures. If the procedure is not within your capabilities or you do not have the correct tools, have a Harley-Davidson dealer perform the installation. Improper installation of this kit could result in death or serious injury. (00333b)

NOTE

This instruction sheet references Service Manual information. A Service Manual for your model motorcycle is required for this installation and is available from a Harley-Davidson Dealer.

Kit Contents

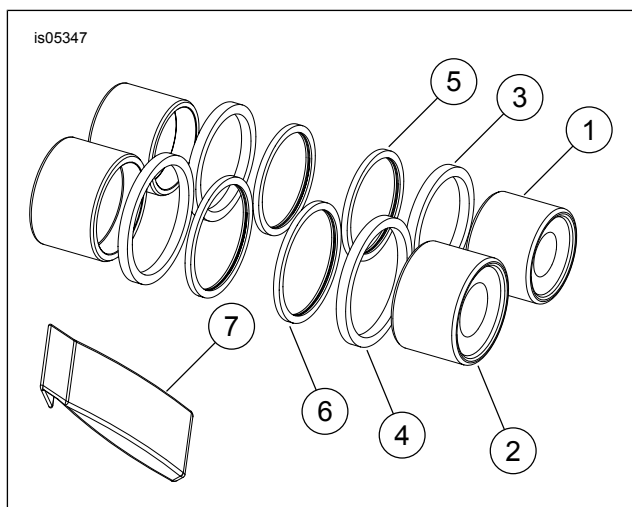

Figure 1. XR1200 Front Caliper Piston Kit

Table 1. Service Parts

Item	Description (Quantity)	Part Number
1	Piston, 30.23 dia. (2)	Not Sold Separately
2	Piston, 30.96 dia. (2)	Not Sold Separately
3	Piston seal (2)	Not Sold Separately
4	Piston seal (2)	Not Sold Separately
5	Dust seal (2)	Not Sold Separately
6	Dust seal (2)	Not Sold Separately
7	Brake grease	42820-04

INSTALLATION

1. Refer to "FRONT BRAKE CALIPER: XR MODELS" in the Service Manual to replace the brake caliper pistons.