



INSTRUCTIONS

-J04501

REV. 2007-06-01

DETACHABLE WINDSHIELD KITS

GENERAL

Kit Number

58158-08 and 57838-08

Models

For model fitment information, please see the P&A Retail Catalog or the Parts and Accessories section of www.harley-davidson.com (English only).

Table 1. Kits

Kit No.	Description
58158-08	Touring windshield
57838-08	Super Sport windshield

Kit Contents

See Figure 13 and Table 2 or Figure 14 and Table 3.

INSTALLATION

WARNING

The rider's safety depends upon the correct installation of this kit. If the procedure is not within your capabilities or you do not have the correct tools, have a Harley-Davidson dealer perform the installation. Improper installation of this kit could result in death or serious injury. (00308a)

WARNING

To prevent accidental vehicle start-up, which could cause death or serious injury, disconnect negative (-) battery cable before proceeding. (00048a)

NOTE

Cover front fender and front of fuel tank with clean shop towels to prevent scratching. Damage to the finish could result.

Relocate Clutch Cable

For XL Custom or FXLR models only: Relocate clutch cable, now snugged behind upper fork bracket, in front of handlebars as follows:

1. Move clutch cable from its initial position to behind the back left side of upper fork bracket. Adjust slack, both above and below the fork bracket, to best position cable.
2. If necessary, reposition clutch cable mount ties attached to frame downtube to allow clutch cable to move freely when handlebars turn fully from left to right fork locks. Cycle hand lever several times to confirm.

For all models except XL Custom or FXLR: Relocate clutch cable to inside of handlebars as follows:

1. See Figure 1. Slide rubber boot (1) off clutch cable adjuster (2). The adjuster is located about halfway along clutch cable by front frame downtube.

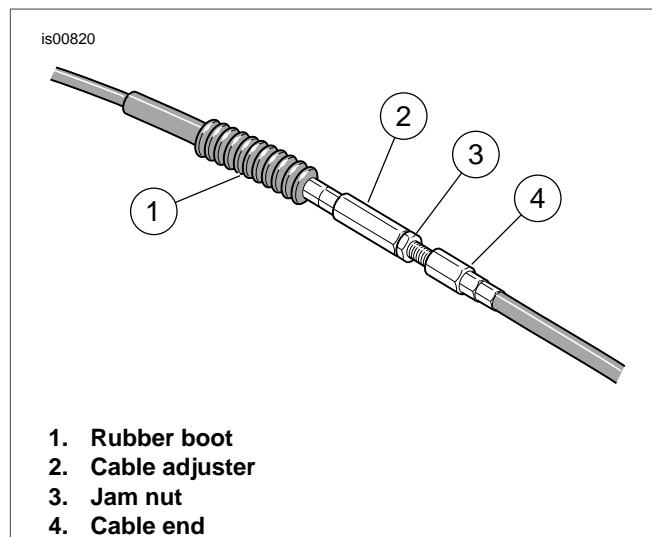

Figure 1. Clutch Cable Adjuster

2. Holding the cable adjuster with a 1/2 in. wrench, loosen jam nut (3) with a 9/16 in. wrench. Back jam nut away from cable adjuster. Move adjuster toward jam nut to allow free play at hand lever.
3. Remove retaining ring from pivot pin groove at bottom of clutch lever bracket, and remove pivot pin.
4. Remove clutch hand lever from bracket. If necessary, use a T27 Torx® drive head to remove two screws with flat washers retaining clutch lever bracket to handlebar clamp.
5. See Figure 2. Re-route the clutch cable to inside of handlebars.

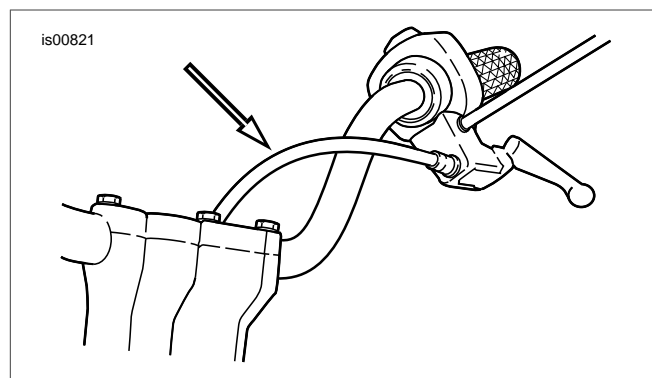

Figure 2. New Clutch Cable Routing

6. Insert clutch lever into lever bracket groove, fitting sleeve at end of cable housing into bore on inboard side of bracket.
7. If removed, secure clutch lever bracket to handlebar clamp with Torx® screws. Starting at top screw, tighten to 60-80 in-lbs (6.8-9.0 Nm).
8. See Figure 1. Turn cable adjuster away from jam nut until slack is eliminated at hand lever. Pull clutch cable ferrule away from clutch lever bracket to measure free play.
9. See Figure 3. Hold adjuster with a 1/2 in. wrench, and use a 9/16 in. wrench to tighten jam nut against cable adjuster. Cover cable adjuster mechanism with rubber boot.
10. If necessary, reposition clutch cable mount ties attached to frame downtube to allow clutch cable to move freely when handlebars turn fully from left to right fork locks. Cycle hand lever several times to confirm.

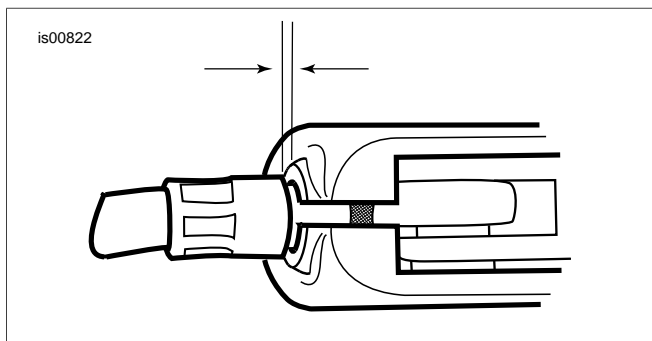

Figure 3. Clutch Cable Free Play, 1/16-1/8 in. (1.6-3.2 mm)

⚠ WARNING

After relocating clutch cable, check that clutch hand lever opens and closes smoothly when handlebars are turned fully left or right. Slow clutch lever response could result in loss of control and death or serious injury (00424d)

⚠ WARNING

Be sure that steering is smooth and free without interference. Interference with steering could result in loss of vehicle control and death or serious injury. (00371a)

- Be sure clutch cables do not pull tight when handlebars are turned fully to left or right fork stops.

NOTE

It may be necessary to relocate the throttle/idle cables. (See Throttle and Cable Routing subtopic.)

Throttle and Idle Cable Routing

⚠ WARNING

Be sure that steering is smooth and free without interference. Interference with steering could result in loss of vehicle control and death or serious injury. (00371a)

- Be sure throttle/idle control cables do not pull tight when handlebars are turned fully to left or right fork stops.
- Be sure wires and cables are clear of fork stops at steering head so they will not be pinched when fork is turned against stops.
- See Figure 4. Use wireform and washer from kit.

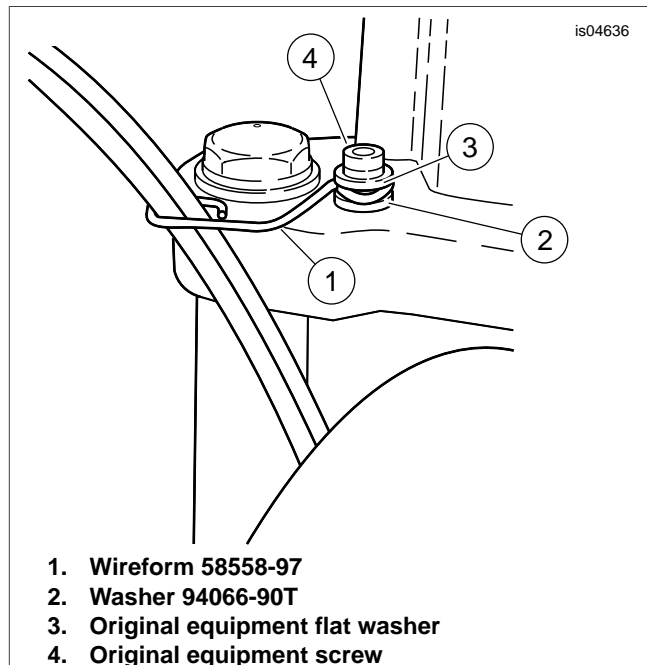

1. Wireform 58558-97
2. Washer 94066-90T
3. Original equipment flat washer
4. Original equipment screw

Figure 4. Throttle Cable Attachment

Sportster Models

Route control cables past left side of right turn signal. Loop back through area between headlight and right fork tube. Route rearward under gas tank and secure at clip under ignition switch, then downward to carburetor.

Dyna Models

FXD, FXDX, FXDS-Conv Models: See Figure 5. Route throttle and idle cables between headlamp and right front fork tube, then under right side of tank to carburetor.

FXDL Models: See Figure 6. Route throttle and idle cables outside (to right of) front forks.

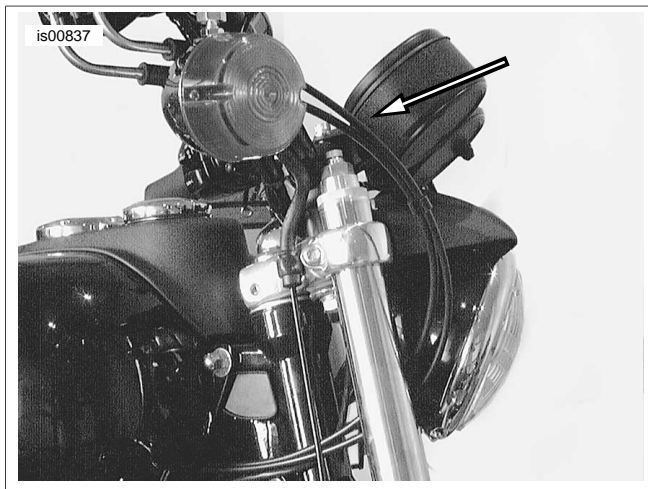

Figure 5. Cable Routing (FXD, FXDX, and FXDS-Conv Models)

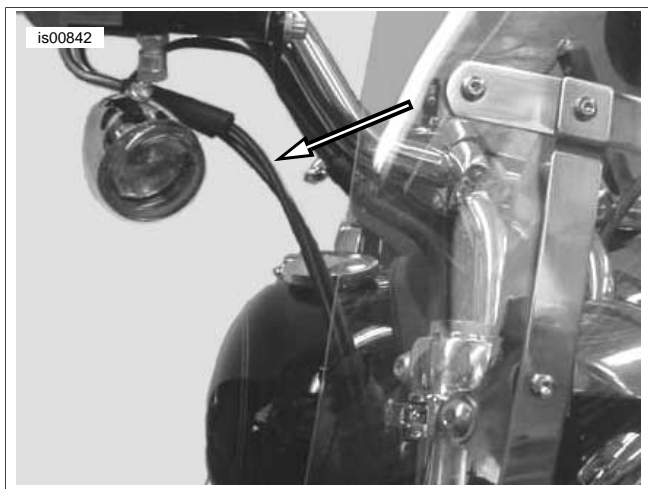

Figure 6. Cable Routing (FXDL Models)

Existing Throttle/Idle Cable Removal

CAUTION

Do not remove or install the master cylinder assembly without first positioning a 5/32-inch (4 mm) thick insert between the brake lever and lever bracket. Removing or installing the master cylinder assembly without the insert in place may result in damage to the rubber boot and plunger on the front stoplight switch. (00324a)

1. See Figure 7. Place cardboard insert between brake lever and lever bracket.
2. See Figure 8. Loosen cable adjuster jam nuts. Screw cable adjusters in until they are as short as possible. This will provide enough slack for easy removal.
3. Using a T25 Torx® drive head, remove right upper and lower switch housing screws.

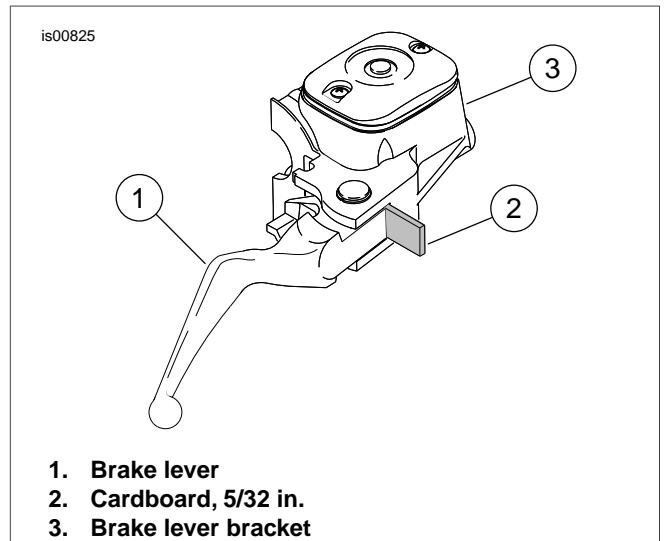

Figure 7. Install Cardboard Insert

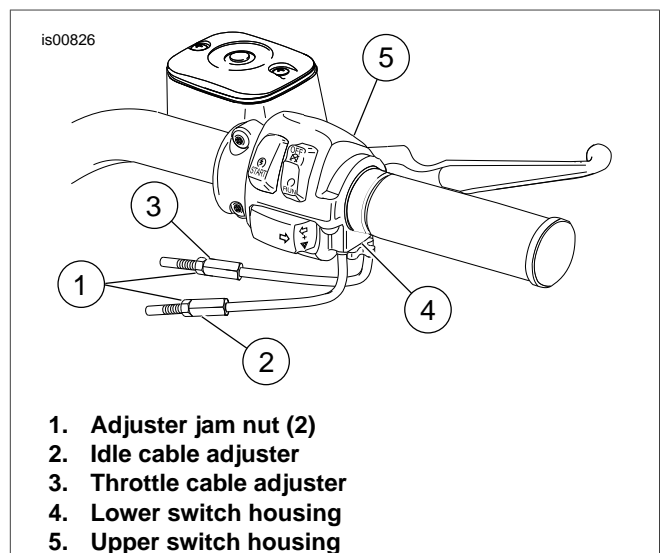

Figure 8. Handlebar Throttle Control

4. Using a T27 Torx® drive head, loosen upper screw securing handlebar clamp to master cylinder housing. Remove lower clamp screw with flat washer.

NOTE

If possible, leave friction shoe in place. The friction shoe is a loose fit and may fall out or become dislodged if lower switch housing is turned upside down or shaken.

5. See Figure 9. Remove brass ferrules from notches on inboard side of throttle control grip. Remove ferrules from cable end fittings.
6. Pull crimped inserts at end of throttle and idle control cable housings from lower switch housing. For best results, use a rocking motion while pulling. Remove cables with retaining rings from switch housing. Place a drop of light oil on the retaining ring, if necessary, to help in removal.

NOTE

At this point, if you have (or are installing) different handlebars, measure the change in distance that will be required from the end of the cable housing to the throttle grip. Compare this additional required length to the cables provided in your kit.

If the cables are more than two inches longer or more than one inch shorter than the above measured distance, see your Harley-Davidson dealer for the correct cable length.

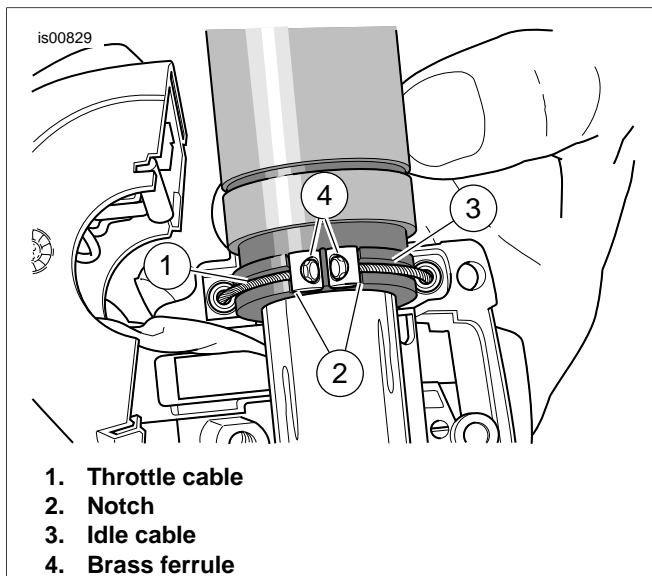

Figure 9. Throttle/Idle Control Cables

Throttle/Idle Cable Installation

1. See Figure 9. Apply graphite lightly to the throttle grip inside the switch housing and on throttle end of handlebar.

NOTES

The throttle control cable has a larger diameter retaining ring crimped to the cable end than does the idle control cable.

For assembly, place a drop of light oil on the retaining rings of the crimped inserts.

2. See Figure 10. Push throttle cable housing and retaining ring into switch housing larger hole, located in front of tension adjuster screw.
3. Push idle cable housing and retaining ring into switch housing smaller hole, located behind tension adjuster screw.
4. Push throttle and idle control cable housings into lower switch housing until each snaps into place.

NOTE

If the friction shoe has fallen out or become dislodged, install the shoe with the concave side facing upward and orient so the pin hole is over the point of the adjuster screw.

5. Push throttle control grip over the end of right handlebar until it bottoms against the closed end. Rotate grip until the ferrule notches are at the top. To prevent binding, pull grip back about 1/8 in. (3.2 mm).

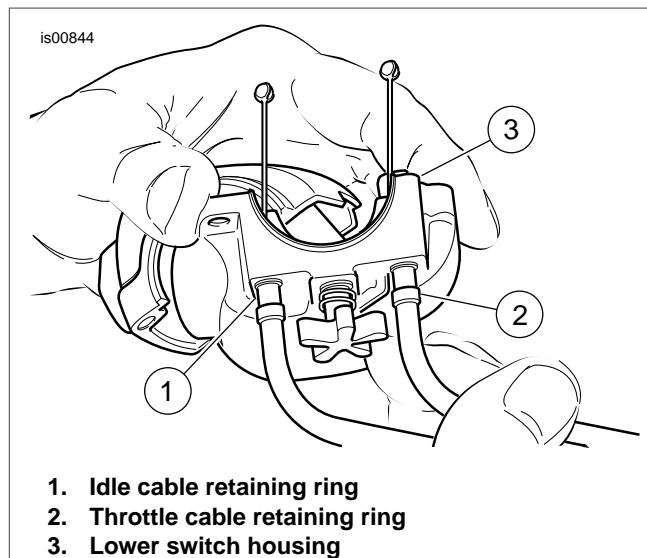

Figure 10. Install Cables to Lower Switch Housing

6. See Figure 9. Position lower switch housing beneath throttle control grip. Install two brass ferrules (56508-76) from kit onto cables, seating the ferrules in their respective notches on throttle control grip. The cables must be captured in the grooves molded into the grip.
7. Position upper switch housing over the handlebar and lower switch housing. Route wire harness conduit through recessed area at bottom of handlebar.
8. Loosely fasten upper and lower switch housing screws.
9. Position brake lever/master cylinder assembly inboard of switch housing assembly, engaging tab on lower switch housing in groove at top of brake lever bracket.
10. Align holes in the handlebar clamp with those in master cylinder housing and loosely fasten lower screw and flat washer. Position for rider comfort. Beginning with top screw, tighten screws to 60-80 **in-lbs** (6.8-9.0 Nm) using a T27 Torx® drive head.
11. Torque lower and upper switch housing screws to 35-45 **in-lbs** (4-5 Nm).

NOTE

Always tighten lower switch housing screw first so that any gap between upper and lower housings is at the front of the switch assembly.

12. Adjust throttle and idle cables according to the Service Manual instructions.
13. Remove cardboard insert between brake lever and lever bracket.

⚠ WARNING

Be sure that steering is smooth and free without interference. Interference with steering could result in loss of vehicle control and death or serious injury. (00371a)

- Cables should not catch on headlamp hardware or pass in front of headlamp.
- Cables should not catch on turn signal mounting hardware or turn signals.
- Cables should not catch on fuel cap or fuel gauge.
- Cables should not catch on speedometer or tachometer.
- Be sure cables are not pinched between the frame and/or forks.
- Be sure clutch cables do not pull tight when handlebars are turned fully to the left or right fork stops.

⚠ WARNING

Connect positive (+) battery cable first. If positive (+) cable should contact ground with negative (-) cable connected, the resulting sparks can cause a battery explosion, which could result in death or serious injury. (00068a)

14. Connect the battery cable, positive (+) cable first.

Assemble Clamps to Windshield

1. See Figure 11. Remove windshield sub-assembly from packaging and place face down on a clean, soft surface with mount brackets facing upward.
2. See Figure 13 or Figure 14. Remove both clamp and hardware kits from packaging, and separate similar parts in preparation for assembly.
3. See Figure 12. Assemble clamp assemblies and hardware stacks.

⚠ WARNING

The cupped side of the Belleville (cone) washers must face each other and sandwich the windshield mount brackets at each mount point. Failure to orient washers correctly can reduce windshield's ability to break away in a collision, which could result in death or serious injury. (00422b)

4. One clamp at a time, with clamp facing upward and inboard of windshield bracket (2), tighten shoulder bolts (1) enough to hold clamp orientation to windshield during mounting of windshield to bike. The bolts will be fully tightened later.

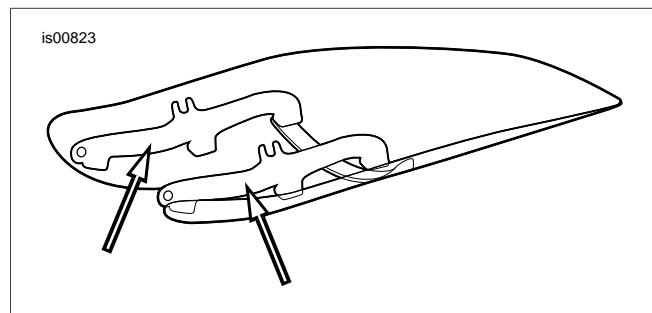

Figure 11. Windshield Mounting Brackets

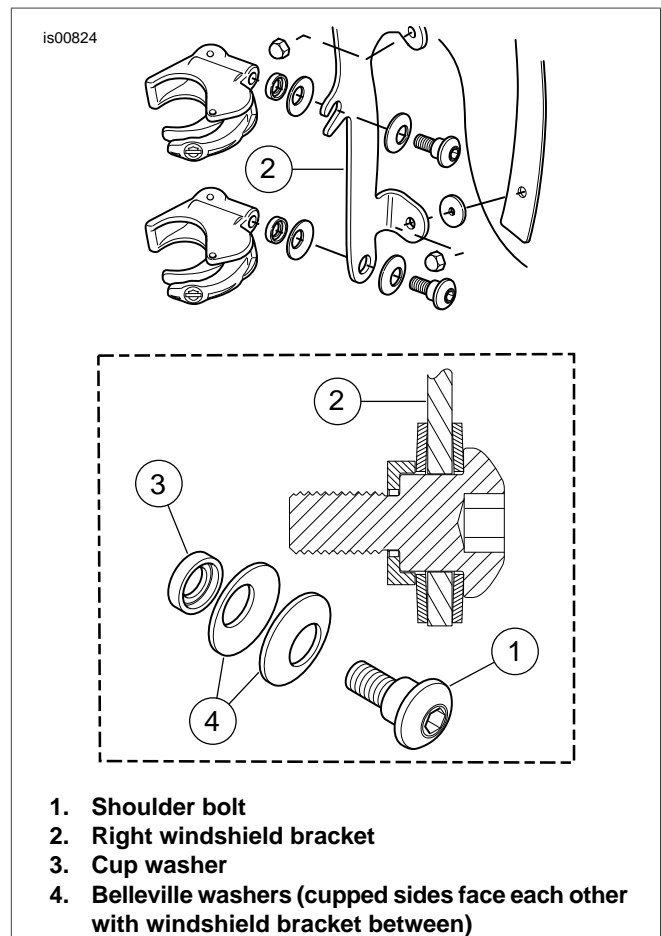

Figure 12. Windshield Mounting Clamp

Install Windshield

NOTE

Keep front wheel straight to prevent brackets from scratching fuel tank.

1. Make sure all four clamps are in the "open" position, then bring windshield (with clamp side away from you) to front of bike.

NOTE

The Lexan® windshield is fairly flexible and can be bent to spread the clamps away from the headlamp to ease installation to the bike. Take care not to scratch the headlamp housing with the clamps while positioning the windshield to the fork sliders.

2. Straddle front fender and check to ensure that throttle cables are positioned between the clamp pair on your left (as viewed facing the bike, holding the windshield), and will not be pinched by the clamps. Center windshield around the headlamp and seat clamps onto fork sliders.

⚠ WARNING

Pinched throttle cables can restrict throttle response, which could result in loss of control and death or serious injury. (00423b)

3. Starting at bottom (either side) with shoulder bolts loosely threaded, close each clamp, noting that clamps self-align to fork sliders and to each other.

NOTE

Do not tighten shoulder bolts beyond the recommended torque. Over-torquing may cause the clamp to twist on the fork slider, yielding the clamp jaw can occur.

4. Make sure that shoulder portion of shoulder bolts are fully seated in each windshield bracket location. Torque each shoulder bolt to 60 **in-lbs** (6.7 Nm).

NOTE

If interference occurs, adjust windshield as needed until proper clearance is obtained. Have experienced Harley-Davidson service personnel correct any problems before riding with this accessory installed.

Remove and Store Windshield

To remove windshield, open four clamps, in any sequence, and reverse installation procedures found in Steps 3 and 4 of Install Windshield subtopic. Take care to not scratch headlamp housing or fuel tank as noted during installation.

When storing windshield, place in a location where windshield clamps will receive the greatest protection. Keep from locations where the windshield may be bumped or dropped. Do not stack anything on top of assembly.

Prior to re-installation after any storage period, inspect clamps and hardware for fastener preload and cleanliness. Each clamp should have a pair of rubber gaskets in the clamp saddle that mates to the fork slider, and should cycle open and closed freely.

CARE AND CLEANING

NOTE

Sunlight reflections off inside surface of windshield can cause extreme heat build-up on motorcycle instruments. Exercise care in parking. Park facing the sun, place an opaque object over instruments, or adjust windshield to avoid reflections.

CAUTION

Harley-Davidson windshields are made of Lexan. Lexan is a more durable and distortion-resistant material than other types of motorcycle windshield material, but still requires attention and care to maintain. Failure to maintain Lexan properly can result in damage to the windshield. (00230a)

- Do not clean Lexan® polycarbonate in hot sun or high temperature. Powdered, abrasive, or alkaline cleanser will damage windshield. Never scrape windshield with a razor blade or other sharp instruments because permanent damage will result.

CAUTION

Do not use harsh chemicals including rain sheeting products on Harley-Davidson windshields. They can cause dulling or hazing. If you want to use a windshield protectant on your windshield, try Harley Glaze Polish and Sealant (00231a)

CAUTION

Do not use benzine, paint thinner, gasoline or any other type of harsh cleaner on the windshield. Doing so will damage the windshield surface. (00232a)

- Do not use benzine, paint thinner, gasoline, lubricants (including Armorall®), or other cleaning agents on rubber bushings. They will damage bushing surfaces.

NOTE

Covering the windshield with a clean, wet cloth for about 15 minutes before washing will make dried bug removal easier.

SERVICE PARTS

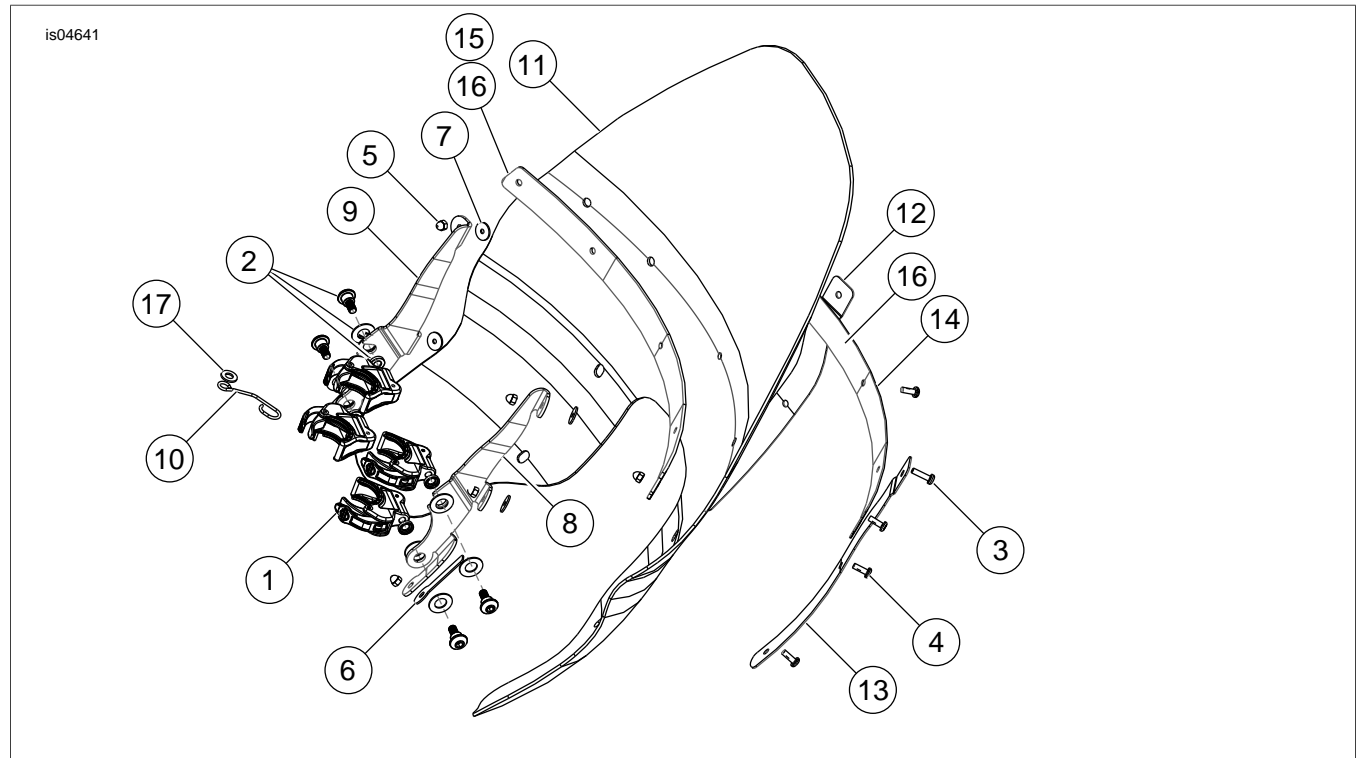

Figure 13. Service Parts: Touring Windshield

Table 2. Service Parts: Touring Windshield

Item	Description (Quantity)	Part Number
1	Clamp assembly, 39 mm (4)	58174-04A
2	Kit, windshield mounting hardware (4)	58790-04
3	Screw, machine pan head special (2)	2452
4	Screw, machine pan head special (7)	2921
5	Nut, #12 acorn (9)	7651
6	Pad, EPDM adhesive (one side) (2)	57036-08
7	Washer, windshield mounting (4)	58152-96
8	Bracket, windshield	58517-08
9	Bracket, windshield	58518-08
10	Wireform, throttle cables	58558-97
11	Service windshield, touring detachable (Includes items 7, 13 and 16)	58571-96
12	Trim strip, vertical	58575-96
13	Trim strip, vertical	58576-96
14	Outerstrip, horizontal	58577-96
15	Innerstrip, horizontal	58578-96
16	Tape, horizontal (2)	58582-96
17	Washer, flat chrome	94066-90T

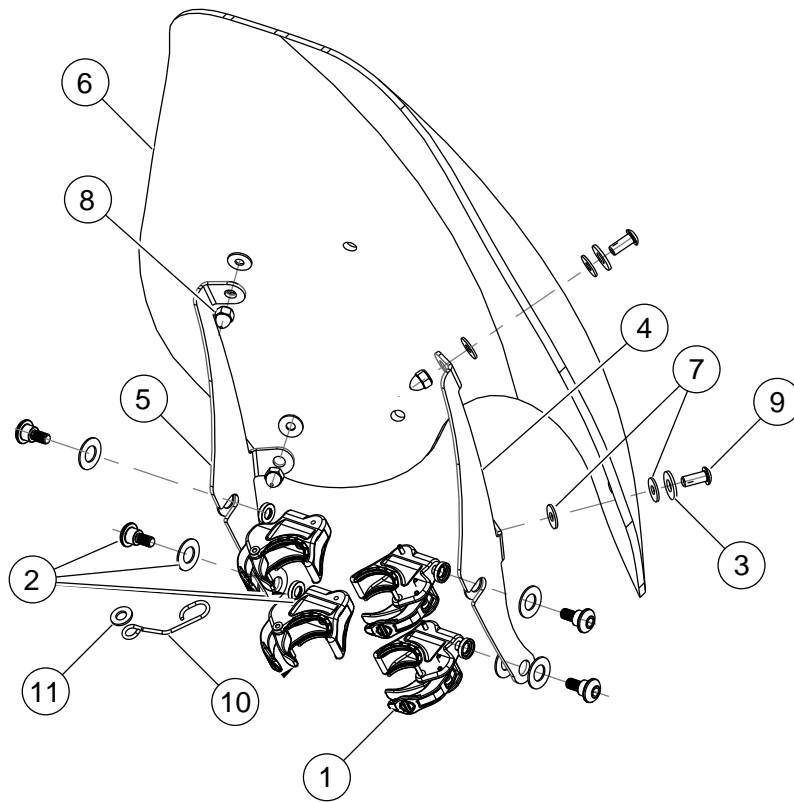

Figure 14. Service Parts: Super Sport Windshield

Table 3. Service Parts: Touring Windshield

Item	Description (Quantity)	Part Number
1	Clamp assembly, 39 mm (4)	58174-04A
2	Kit, windshield mounting hardware (4)	58790-04
3	Washer, plain type A (4)	6352
4	Bracket, windshield detach 39 mm models	57820-08
5	Bracket, windshield detach 39 mm models	57823-08
6	Service windshield, 39 mm Sport detach (includes item 7)	57883-08
7	Washer, windshield mounting (8)	57964-97
8	Nut, acorn 1/4-20 (4)	94007-90T
9	Screw, button head with lock patch (4)	94639-99
10	Wireform, throttle cables	58558-97
11	Washer	94066-90T