



CHROME MASTER CYLINDER AND CLUTCH BRACKET KIT

J03734

2009-03-02

GENERAL

Kit Number

46418-05A, 45355-06A

Models

For model fitment information, see the P&A Retail Catalog or the Parts and Accessories section of www.harley-davidson.com (English only).

Additional Parts Required

WARNING

Rider and passenger safety depend upon the correct installation of this kit. Use the appropriate service manual procedures. If the procedure is not within your capabilities or you do not have the correct tools, have a Harley-Davidson dealer perform the installation. Improper installation of this kit could result in death or serious injury. (00333b)

A service manual for your motorcycle is available from any Harley-Davidson Dealer.

Kit Contents

See [Figure 6](#) and [Table 1](#).

Master Cylinder Removal

See [Figure 1](#). Master cylinders designed for dual disc (two caliper) operation have an 11/16 inch (17.5 mm) bore, while those that are designed for single disc (one caliper) operation have a 9/16 inch (14.3 mm) bore. The bore size is stamped (1) on the master cylinder assembly inboard of the handlebar clamp bracket.

NOTE

Do not use an 9/16 inch bore master cylinder assembly on dual disc (two caliper) models or dual disc 11/16 inch bore master cylinder assembly on single disc (one caliper) models. These master cylinder assemblies are not interchangeable. Using the wrong assembly can adversely affect braking efficiency or result in brake failure which could result in death or serious injury.

NOTICE

DOT 4 brake fluid will damage painted and body panel surfaces it comes in contact with. Always use caution and protect surfaces from spills whenever brake work is performed. Failure to comply can result in cosmetic damage. (00239c)

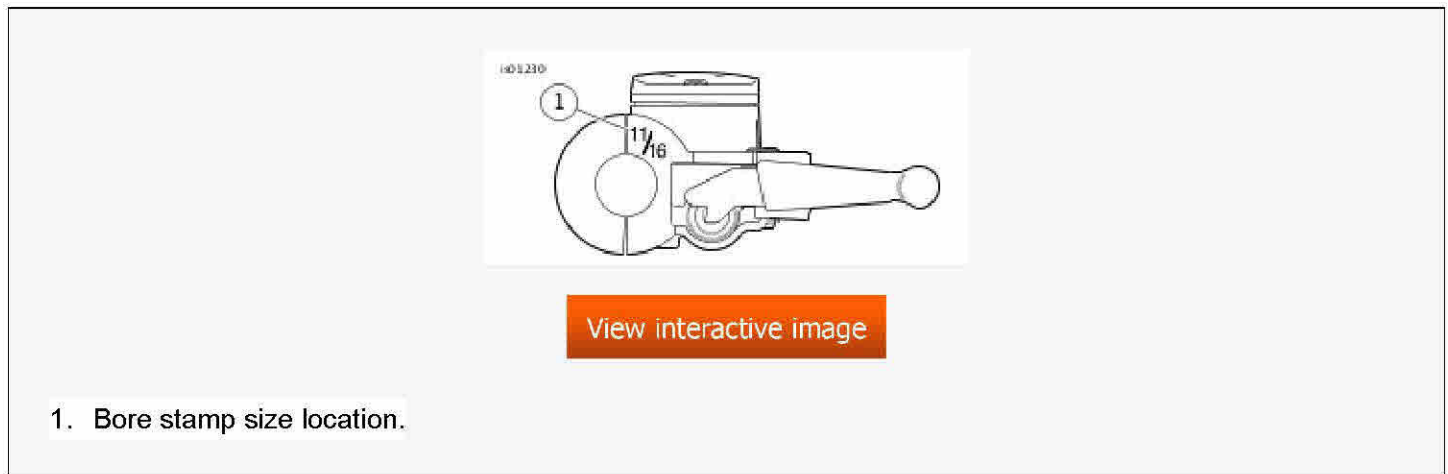

1. Bore stamp size location.

Figure 1. Verify Correct Master Cylinder Bore Size

1. Open bleeder nipple caps on front brake caliper. Install end of a length of clear plastic tubing over caliper bleeder valves, while placing free end in a suitable container. Open bleeder valves about 1/2-turn. Pump brake hand lever to drain brake fluid. Close bleeder valve.

NOTICE

Avoid leakage. Be sure gaskets, banjo bolt(s), brake line and master cylinder bore are clean and undamaged before assembly. (00322a)

2. Remove bolt and two steel/rubber washers to disconnect fitting of hydraulic brake line from master cylinder. Discard washers.

NOTICE

Do not remove or install the master cylinder assembly without first positioning a 5/32-inch (4 mm) thick insert between the brake lever and lever bracket. Removing or installing the master cylinder assembly without the insert in place may result in damage to the rubber boot and plunger on the front stoplight switch. (00324a)

3. See [Figure 2](#). Place the cardboard insert between the brake lever and lever bracket.



4. See [Figure 6](#). Using T27 TORX® drive head, remove the two screws with flat washers securing the handlebar clamp to the master cylinder housing. Remove the brake lever/master cylinder assembly and clamp from the handlebar.

⚠ WARNING

Wear safety glasses or goggles when removing or installing retaining rings. Retaining rings can slip from the pliers and could be propelled with enough force to cause serious eye injury. (00312a)

5. Remove retaining ring from pivot pin groove at bottom of master cylinder bracket.
6. Remove pivot pin and brake hand lever from master cylinder assembly.

NOTE

New master cylinder comes with all internal components preassembled. It is not necessary to remove the components from the bore of the old master cylinder. See Service Parts page.

NOTICE

Do not allow dirt or debris to enter the master cylinder reservoir. Dirt or debris in the reservoir can cause improper operation and equipment damage. (00205c)

7. Clean all previously used parts with denatured alcohol or D.O.T. 4 BRAKE FLUID. Do not contaminate with mineral oil or other solvents. Wipe dry with a clean, lint

free cloth.

⚠ WARNING

Use denatured alcohol to clean brake system components. Do not use mineral-based solvents (such as gasoline or paint thinner), which will deteriorate rubber parts even after assembly. Deterioration of these components can cause brake failure, which could result in death or serious injury. (00291a)

8. Carefully inspect all parts for wear or damage and replace as necessary.

Master Cylinder Installation

1. Align hole in brake hand lever with hole in master cylinder bracket. From the top of the assembly, slide pivot pin through bracket and hand lever.

⚠ WARNING

Wear safety glasses or goggles when removing or installing retaining rings. Retaining rings can slip from the pliers and could be propelled with enough force to cause serious eye injury. (00312a)

2. Install retaining ring in pivot pin groove. Verify that retaining ring is completely seated in groove.

NOTICE

Do not remove or install the master cylinder assembly without first positioning a 5/32-inch (4 mm) thick insert between the brake lever and lever bracket. Removing or installing the master cylinder assembly without the insert in place may result in damage to the rubber boot and plunger on the front stoplight switch. (00324a)

3. See [Figure 3](#). Position the brake lever/master cylinder assembly inboard of the switch housing (4) assembly engaging the tab (1) on the lower switch housing in the groove (3) at the top of the brake lever bracket (2).

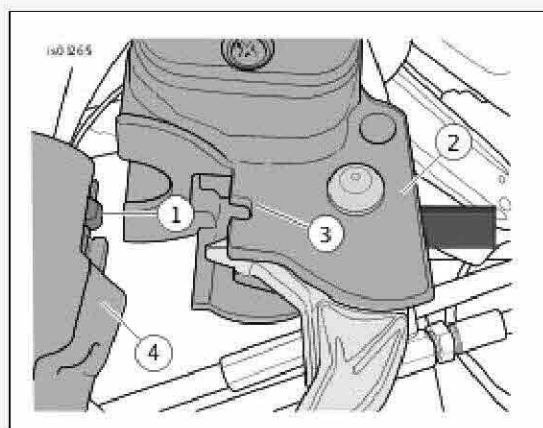

[View interactive image](#)

1. Tab.
2. Brake lever bracket.
3. Groove.
4. Switch housing.

Figure 3. Brake Lever Bracket to Switch Housing

4. Align the holes in the handlebar clamp with those in the master cylinder housing and start the two screws (with flat washers). Position for rider comfort. Beginning with the top screw, tighten the screws to **70-80 in-lbs (7.9-9.0 Nm)** using a T27 TORX drive head.

NOTICE

Avoid leakage. Be sure gaskets, banjo bolt(s), brake line and master cylinder bore are clean and undamaged before assembly. (00322a)

5. Position new steel/rubber washers (included in kit) on each side of hydraulic brake line fitting. Insert bolt through washers and fitting. Thread bolt into master cylinder housing and tighten to **17-22 ft-lbs (25-30 Nm)**.
6. Install length of clear plastic tubing over caliper bleeder valve, if removed. Place free end of tube in a clean container.
7. Remove the master cylinder cover. Stand the motorcycle upright so that the master cylinder is in a level position.

NOTE

The cover is labeled for D.O.T. 4 BRAKE FLUID. Install this cover on reservoirs filled only with D.O.T. 4 BRAKE FLUID. Do not mix grades of brake fluid as they are not compatible and could cause equipment damage.

NOTE

Never mix D.O.T 4 with other brake fluids (such as D.O.T. 5). Mixing different types of fluid may adversely affect braking ability and lead to brake failure which could result in death or serious injury.

⚠ CAUTION

Direct contact of DOT 4 brake fluid with eyes can cause irritation. Avoid eye contact. In case of eye contact flush with large amounts of water and get medical attention. Swallowing large amounts of DOT 4 brake fluid can cause digestive discomfort. If swallowed, obtain medical attention. Use in well ventilated area. KEEP OUT OF REACH OF CHILDREN. (00240b)

8. Add D.O.T. 4 SILICONE HYDRAULIC BRAKE FLUID to the master cylinder reservoir until the fluid level is 1/8 inch (3.2 mm) from the top. Do not reuse old brake fluid. Use only D.O.T. 4 fluid from a sealed container.

⚠ WARNING

Be sure the master cylinder relief port is not plugged. A plugged relief port can cause brake drag or lockup and loss of vehicle control, which could result in death or serious injury. (00317a)

9. Verify proper operation of the master cylinder relief port. Actuate the brake hand lever. A slight spurt of fluid will brake the fluid surface in the reservoir compartment if all internal components are working properly.
10. Add brake fluid to the master cylinder reservoir until the fluid level is 1/8 inch (3.2 mm) from the top.
11. Press and hold the brake hand lever to build up hydraulic pressure.
12. Open bleeder valve about 1/2-turn. Brake fluid will flow from bleeder valve through tubing. Close bleeder valve when brake hand lever has moved 1/2 to 3/4 of its full range of travel. Allow brake hand lever to return slowly to its released position.
13. Repeat Steps 10 through 12 until all air bubbles are purged.
14. Final tighten the bleeder valve to 80-100 in-lbs (9.0-11.3 Nm). Install the bleeder cap.
15. Add brake fluid to the master cylinder reservoir until the fluid level is about 1/8 inch (3.2 mm) from the top.

16. Note that the angular shape of the master cylinder cover makes one side thicker than the other. Install the cover (with gasket) on the master cylinder reservoir so that the thicker side is positioned above the brake line fitting. Install two Phillips screws to fasten the cover to the reservoir. Tighten the screws to 1.4–1.7 N·m (12–15 in-lbs).
17. With the Ignition/Light Key Switch turned to IGNITION, actuate the front brake hand lever to verify operation of the brake lamp.

⚠ WARNING

After repairing the brake system, test brakes at low speed. If brakes are not operating properly, testing at high speeds can cause loss of control, which could result in death or serious injury. (00289a)

18. Test ride the motorcycle. If the brake feels spongy, repeat the bleeding procedure.

NOTE

The sight glass enables the rider to visually check the brake fluid level without removing the master cylinder cover. When the reservoir is full, the sight glass is dark. As the fluid level drops, the glass lightens up to indicate this condition to the rider.

Clutch Lever Bracket Removal

1. Stand motorcycle upright and level.
2. See [Figure 4](#). Loosen clutch adjuster so clutch cable is fully slack by performing the following:
 - a. Slide rubber boot (1) off cable adjuster.
 - b. Holding cable adjuster (2) with 1/2 inch wrench, loosen jam nut (3) using a 9/16 inch wrench.
 - c. Back jam nut (3) away and turn cable adjuster (2) toward jam nut to introduce a large amount of free play at the clutch hand lever.

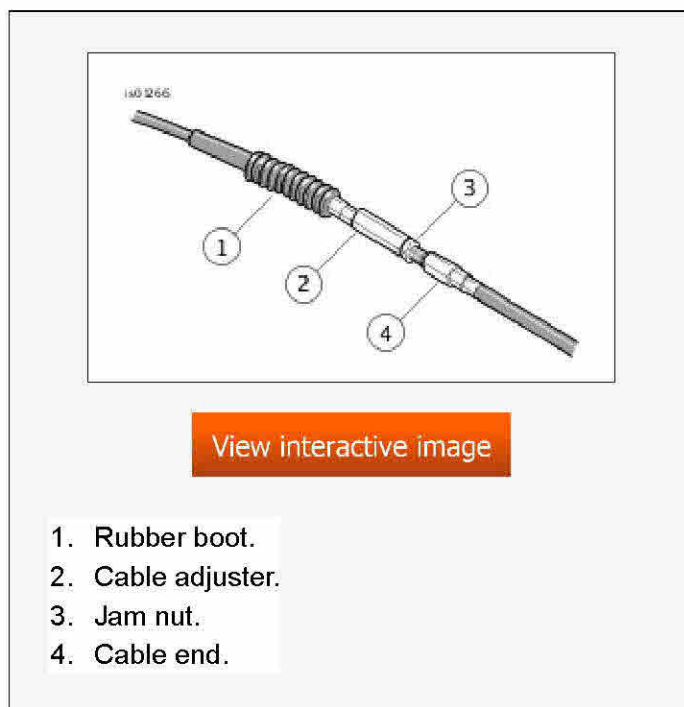

Figure 4. Loosen Clutch Adjuster

⚠ WARNING

Wear safety glasses or goggles when removing or installing retaining rings. Retaining rings can slip from the pliers and could be propelled with enough force to cause serious eye injury. (00312a)

3. See [Figure 6](#). Remove the clutch cable anchor pin (D) from the hand lever (G). To remove anchor pin, it will be necessary to remove the retaining ring (C) and pivot pin (A).
4. Remove clevis (E) and clutch lever.
5. Using a T27 TORX drive head, remove the two screws with flat washers securing the handlebar clamp to the clutch lever bracket.

Clutch Lever Bracket Installation

1. See [Figure 6](#). Install the clutch cable (F) and anchor pin (D) in the clutch hand lever (G). The flat in the pin must face in towards the hand lever.
2. Put cable clevis in position in clutch lever and slide anchor pin into place.

⚠ WARNING

Wear safety glasses or goggles when removing or installing retaining rings. Retaining rings can slip from the pliers and could be propelled with enough force to cause serious eye injury. (00312a)

3. Place clutch lever in new bracket and install pivot pin and retaining ring.
4. Align the holes in the handlebar clamp with those in the clutch lever bracket and start the two screws (with flat washers). Position for rider comfort. Beginning with the top screw, tighten the screws to 7.9–9 N·m (70–80 in-lbs).
5. Adjust clutch lever free play by performing the following:
 - a. See [Figure 4](#). Turn cable adjuster (2) away from jam nut (3) until slack is eliminated at hand lever
 - b. See [Figure 5](#). Pull clutch cable ferrule (2) away from clutch lever bracket (3) to check free play. Turn cable adjuster as necessary to obtain 1/16-1/8 inch (1.6-3.2 mm) free play between end of cable ferrule and clutch

lever bracket.

c. Hold adjuster with 1/2 inch wrench. Using 9/16 inch wrench, tighten jam nut against cable adjuster.

d. Cover cable adjuster with rubber boot.

6. Check clutch lever for proper operation.

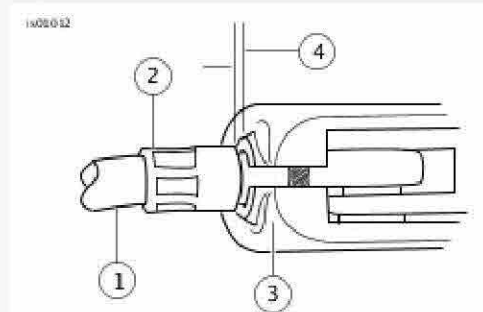

[View interactive image](#)

1. Clutch cable.
2. Cable ferrule.
3. Clutch lever bracket.
4. Freeplay 1/16-1/8 in. (1.6-3.2 mm).

Figure 5. Clutch Hand Lever

NOTE

If clutch adjustment is necessary, refer to the applicable service manual.

SERVICE PARTS

NOTE

Item 6, Repair Kit, is Preassembled. Components shown for illustration purposes only.

Only Items 1 and 3 are Included in Kit. Others shown for illustration purposes only.

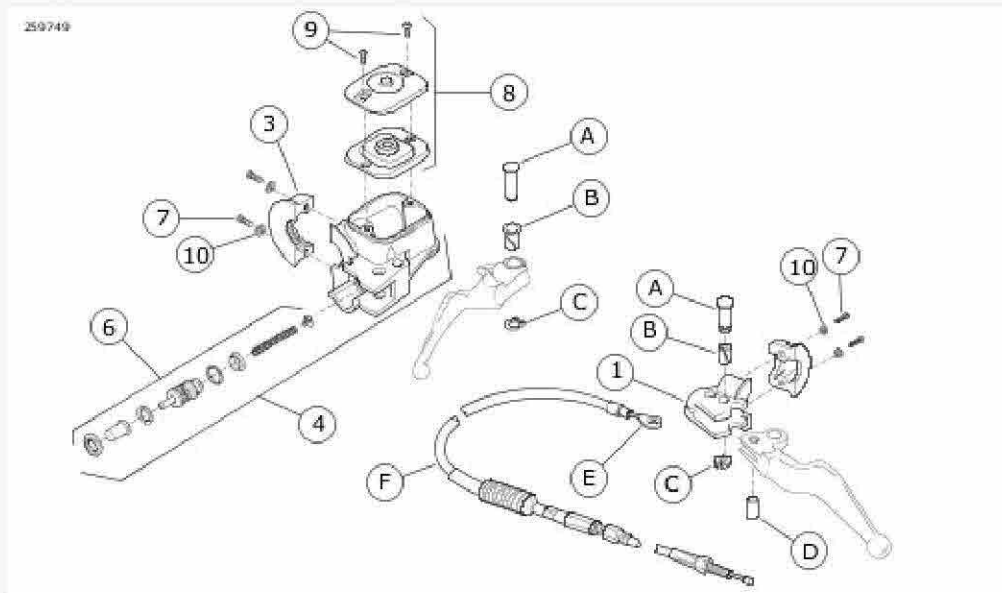

[View interactive image](#)

Figure 6. Service Parts: Chrome Master Cylinder And Clutch Bracket Kit

Table 1. Service Parts Table

ITEM	DESCRIPTION (QUANTITY)	PART NUMBER	ITEM	DESCRIPTION (QUANTITY)	PART NUMBER
1	Bracket, clutch lever for kits: 46418-05A and 45355-06A	38403-99	9	Screw, oval head, 8/32 stainless steel (2) for kits: 46418-05A and 45355-06A	2573
2	Gasket, brakeline banjo (2) (not shown) for kit 46418-05A	41731-88A	10	Washer (4) for kits: 46418-05A and 45355-06A	6099
	Gasket, brakeline banjo (2) (not shown) for kit 45355-06A	41733-88			
3	Clamp, master cylinder and clutch (2) for kits: 46418-05A and 45355-06A	45282-99A	A	Pivot pin	Reference only
4	Assy, master cylinder 11/16 chrome (includes Items 5 and 6 assembled) for kit 46418-05A	45298-99	B	Bushing	Reference only
	Assy, master cylinder 9/16 chrome (includes Items 5 and 6 assembled) for kit 45355-06A	45297-99A	C	Retaining ring	Reference only
5	Body, master cylinder chrome	Not Sold	D	Anchor pin	Reference only
6	Repair kit, master cylinder 11/16 dia. for kit 46418-05A	45072-96B	E	Clevis end	Reference only

ITEM	DESCRIPTION (QUANTITY)	PART NUMBER		ITEM	DESCRIPTION (QUANTITY)	PART NUMBER
7	Screw, socket button head, 1/4-20 x 1-1/8 inch (4)for kits: 46418-05A and 45355-06A	4293		F	Clutch cable	Reference only
8	Cover assembly, master cylinder kit	46424-05B		G	Clutch hand lever	Reference only