



# INSTRUCTIONS

-J03167

REV. 2007-05-15

## CUSTOM FOOTPEG KIT

### GENERAL

#### Kit Number

50576-05

#### Models

These footpegs fit all Harley-Davidson "male mount" style footpeg supports.

There are no serviceable parts in this kit.

### INSTALLATION

#### WARNING

The rider's safety depends upon the correct installation of this kit. Use the appropriate service manual procedures. If the procedure is not within your capabilities or you do not have the correct tools, have a Harley-Davidson dealer perform the installation. Improper installation of this kit could result in death or serious injury. (00333a)

#### NOTE

A Service manual for your motorcycle is available at your Harley-Davidson Dealer.

1. See Figure 1. The footpeg shown in Figure 1 is different from the footpeg in the kit, however the installation is identical. Remove the locknuts and screws that hold the existing footpegs in place. Save all hardware for installation of the new footpegs.
2. Remove the existing footpegs along with the spring washers. Save the spring washers for later installation.

#### NOTE

When performing Step 3, make sure the spring washer is position inside the footpeg support with the square edge toward the inside of the support as shown in Figure 2.

3. Install the new footpegs in the same manner as the old footpegs were installed. Place a spring washer, along with the mount end of the footpeg, inside the slots of the footpeg supports.
4. Secure each footpeg and spring washer with the screw and locknut removed earlier. Tighten the locknuts to 19 ft-lbs (26 Nm).

#### WARNING

Footrests must fold up and toward rear of motorcycle if struck. Failure to set footrests to fold up and back could result in death or serious injury. (00366a)

5. For each footpeg, loosen the adjusting screw in the recessed hole until the footpeg rotates. Position the footpeg as desired, then tighten the adjusting screw to 21 ft-lbs (29 Nm).

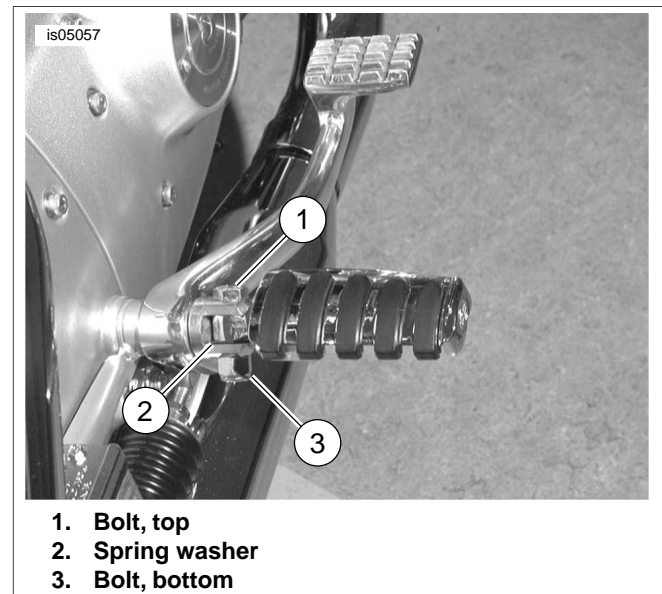

Figure 1. Footpeg Removal and Installation

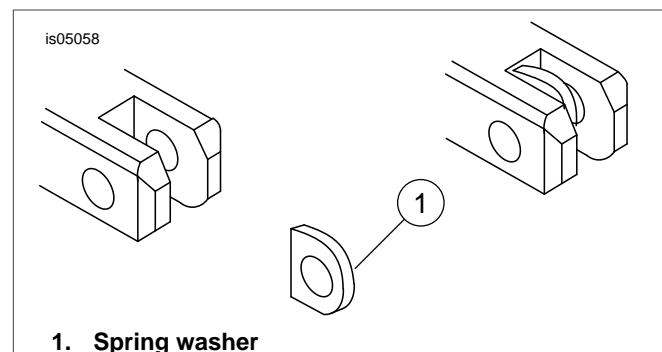

Figure 2. Footpeg Spring Washer Installation