



INSTRUCTIONS

-J03053

REV. 7-08-03

Kit Number 25386-04

XL DERBY COVER KIT

General

This kit is designed for use on 2004 and later XL model motorcycles.

NOTE

A Service Manual for your model motorcycle is available from any Harley-Davidson Dealer.

Installation

1. See Figure 1. Remove six capscrews and the cover.
2. Wipe groove on mating cover clean of any excess oil or debris.
3. Inspect O-ring for damage. If needed, replace with service part number 25463-94.
3. See Figure 2 and the Service Parts Illustration. Install the new cover, cable guard insert, buttonhead capscrews and flat washers. Cable guard should be located with hole inward toward the center of the circle as shown below. The insert seats in the derby cover over the cable and is held captive once the buttonhead screws are tightened. Tighten buttonhead capscrews to 84-108 **in-lbs** (9.5-12.2 Nm).

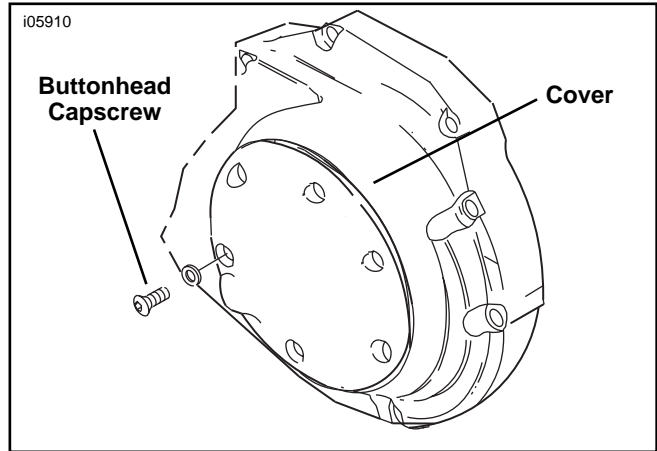

Figure 1. Location of 2004 Derby Cover

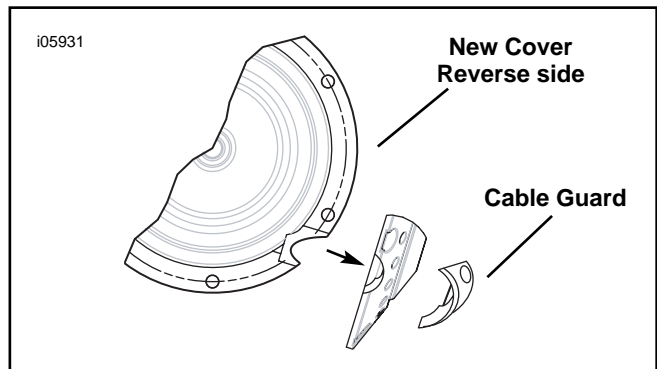

Figure 2. 2004 Derby Cover reverse side and Cable Guard



Service Parts

Part No. 25386-04

Date 7/03

XL Derby Cover Kit

Item	Description	Part Number
1	Derby cover	Not sold separately
2	Insert, Derby cover	25385-04
3	Screw, 1/4-18 x 5/8 socket button head (6)	94592-98
4	Washer, flat stainless steel 1/4 in (6)	94629-04

