



# INSTRUCTIONS

-J03042

REV. 2014-03-13

## CHROME HORN KIT

### GENERAL

#### Kit Number

69112-95E

#### Models

For model fitment information, see the P&A Retail Catalog or the Parts and Accessories section of [www.harley-davidson.com](http://www.harley-davidson.com) (English only).

#### Additional Parts Required

Loctite® 243 (Blue) Threadlocker and Sealant (H-D Part Number 99642-97) is needed for the proper installation of this kit.

### ⚠ WARNING

The rider's safety depends upon the correct installation of this kit. Use the appropriate service manual procedures. If the procedure is not within your capabilities or you do not have the correct tools, have a Harley-Davidson dealer perform the installation. Improper installation of this kit could result in death or serious injury. (00333a)

#### NOTE

*This instruction sheet references Service Manual information. A Service Manual for your model motorcycle is required for this installation and is available from a Harley-Davidson Dealer.*

#### Kit Contents

See Figure 10 and Table 1.

### INSTALLATION

#### Preparation

1. **2007 and later models:** Refer to the Service Manual and follow the procedures under FUEL TANK, PURGING AND DISCONNECTING THE FUEL LINE.

ALL models:

### ⚠ WARNING

To prevent accidental vehicle start-up, which could cause death or serious injury, disconnect battery cables (negative (-) cable first) before proceeding. (00307a)

### ⚠ WARNING

Disconnect negative (-) battery cable first. If positive (+) cable should contact ground with negative (-) cable connected, the resulting sparks can cause a battery explosion, which could result in death or serious injury. (00049a)

- For **2004 and later** models, the negative battery cable is most easily disconnected **at the engine crankcase**.
2. Refer to the Service Manual and follow the instructions given to remove the seat and disconnect the battery cables, negative cable first. Retain all seat mounting hardware.

### ⚠ WARNING

When servicing the fuel system, do not smoke or allow open flame or sparks in the vicinity. Gasoline is extremely flammable and highly explosive, which could result in death or serious injury. (00330a)

3. Remove the fuel tank from the vehicle. Refer to FUEL TANK, REMOVAL in the Service Manual.  
The original equipment (O.E.) hex head screw that secured the front of the fuel tank can be discarded. Retain all other fuel tank components and hardware for re-assembly.
4. See Figure 10 and Table 1. Obtain the following items from the kit:
  - Horn assembly, Item 1
  - Chrome horn cover assembly, Item 3
  - (2) speed nuts, Item 4
  - 5/16 in. internal-tooth lockwasher, Item 5
  - Horn mounting bracket, Item 6
  - (2) 1/4-20 x 3/8 in. long flanged hex head screws, Item 7
  - Wire clip, Item 8
5. See Figure 1. Use a 10 mm wrench to remove the flanged hex nut (3) from the mounting stud (1) of the **new** horn (5) from the kit. Assemble the chrome horn cover (4) onto the horn using the middle hole in the horn cover bracket (6), as shown.  
Install the internal-tooth lockwasher (2) from the kit onto the horn mounting stud. Apply 1-2 drops of Loctite® 243 (Blue) to the threads of the flanged hex nut, and install the nut to the horn mounting stud. Tighten the nut to **110 in-lbs** (12.3 Nm).
6. Push the two speed nuts (7) from the kit over the holes in the top and bottom ears of the horn cover bracket.

7. See Figure 2. Align the horn mounting bracket (1) over the speed nuts on the horn cover bracket (2). Install one of the flanged hex head screws (3) from the kit through the bottom speed nut.
8. Insert the remaining screw (4) through the hole in the horn wire clip (5), and secure the screw to the top speed nut. Tighten the screws to 5-8 in-lbs (.56-.90 Nm).  
Continue with **Horn Installation** for the correct year vehicle.

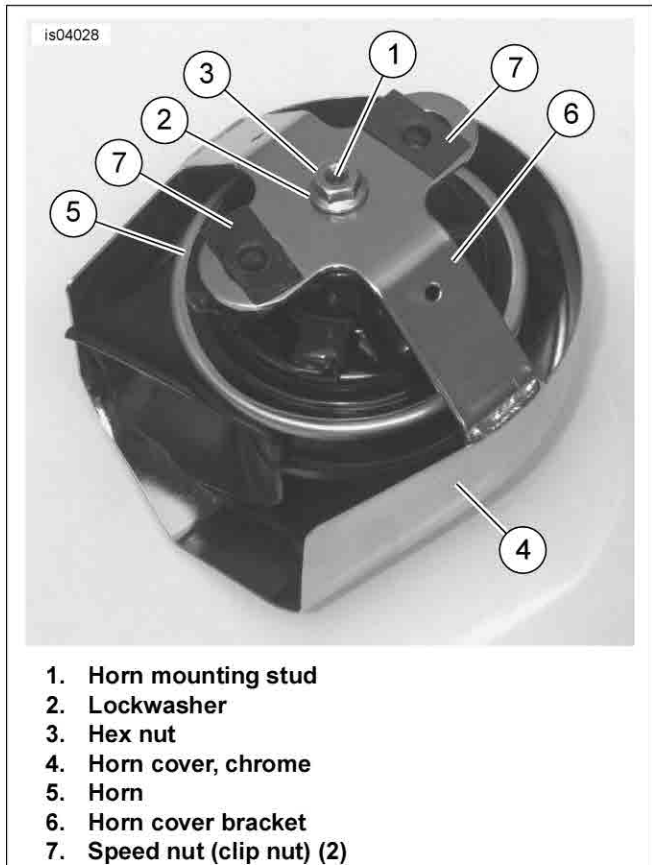

Figure 1. Horn Cover and Hardware, All Models

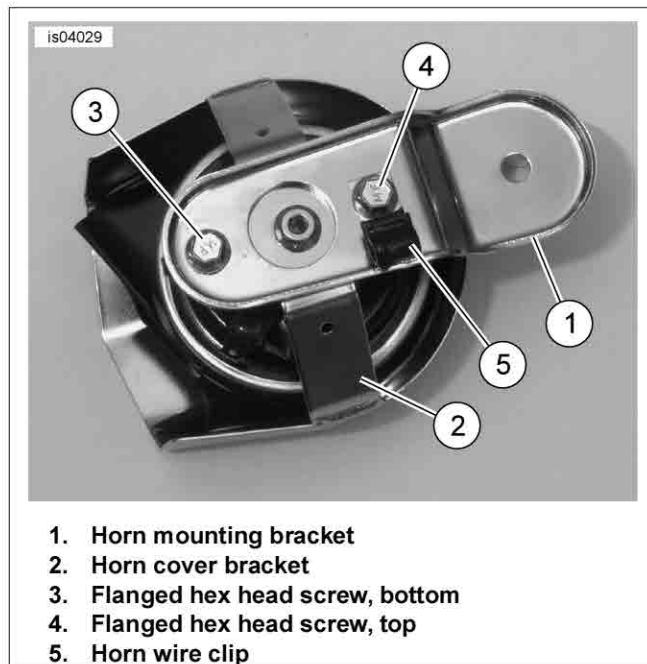

Figure 2. Horn Mounting Bracket Installation

### Horn Installation, 1992 Through 1994 Models

1. Cut the cable strap securing the horn wire lead(s) to the frame. Remove the horn wire(s) from the wire bundle. Secure the remaining wires to the frame with a new cable strap (26) from the kit.
2. Route the horn wires, with terminal clips, from the front mounted horn down behind the engine center mounting bracket for later installation to the new side mounted chrome horn kit.
3. Refer to HORN, REMOVAL in the Service Manual and follow the instructions for removing the O.E. front mounted horn assembly for your model.
4. **For 1992 models:** Obtain the 5/16-18 x 3 in. hex head cap screw (23) from the kit.  
**For 1993 and 1994 models:** Obtain the 5/16-18 x 3-5/8 in. hex head cap screw (24) from the kit.

### **⚠ WARNING**

**When servicing the fuel system, do not smoke or allow open flame or sparks in the vicinity. Gasoline is extremely flammable and highly explosive, which could result in death or serious injury. (00330a)**

5. Install the fuel tank to the vehicle, using the **new** screw obtained in Step 4 and the remaining hardware removed earlier. Refer to FUEL TANK, INSTALLATION in the Service Manual. Tighten the fuel tank front mounting screw to 96-192 in-lbs (10.8-21.6 Nm)

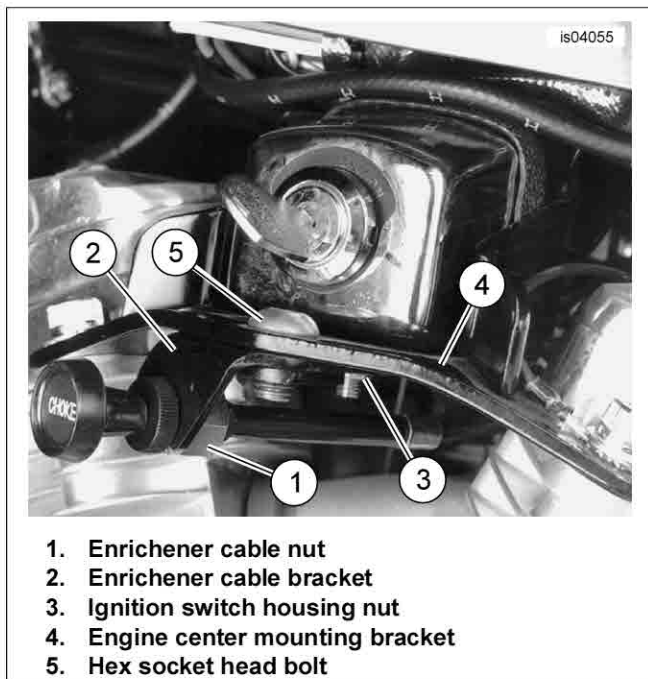

Figure 3. Original Enricher Bracket, 1992-1994 Models

**NOTE**

Turn the nut on the back of the enricher cable **clockwise** to loosen.

6. See Figure 3. Loosen the nut (1) on the back of the enricher cable. Remove the cable from the enricher bracket (2), and let it hang free.
7. Loosen the ignition switch housing lock nut (3) on the underside of the engine center mounting bracket (4). Remove the hex socket head bolt (5) and the original equipment enricher bracket from the top of the engine center mounting bracket.
8. See Figure 10 and Table 1. Obtain the following items from the kit:
  - Horn and enricher cable bracket, Item 9
  - 3/8-16 x 5/8 in. long button head screw, Item 10
  - Rubber horn mount, Item 11
  - 5/16-18 flanged locknut, Item 12
  - Ground wire, Item 13
  - Split lockwasher, 5/16 in., Item 14
  - Acorn nut, high crown, 5/16-18, Item 15
9. See Figure 4. Install the **new** horn and enricher cable bracket (1) to the engine center mounting bracket (2) using the new screw (3). Tighten the screw to 60-120 **in-lbs** (6.8-13.6 Nm).

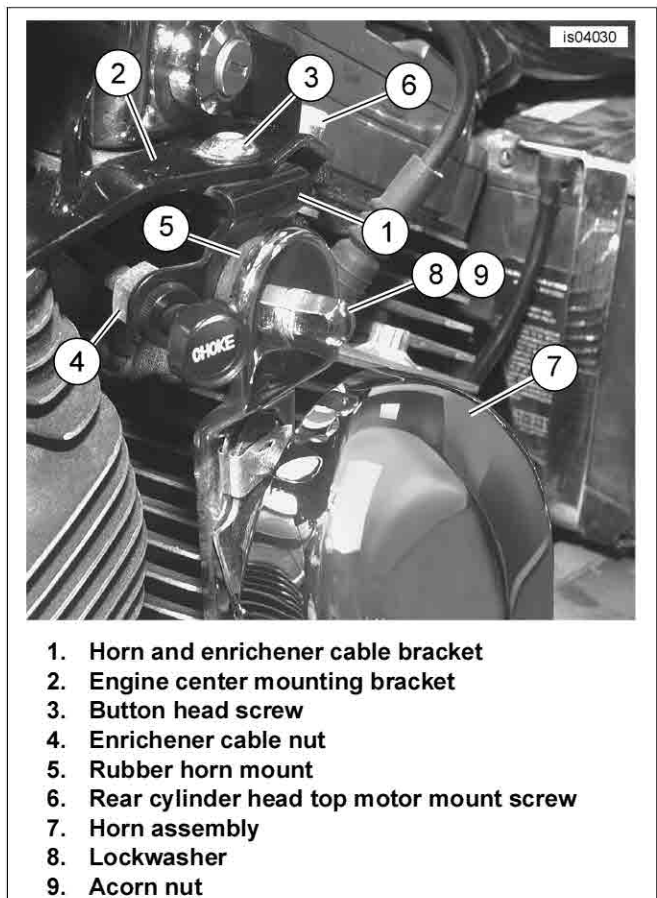

Figure 4. Horn Assembly Installation, 1992-1994 Models

10. Tighten the ignition switch housing lock nut loosened in Step 7 to 6 ft-lbs (8 Nm).

**NOTE**

Turn the nut on the back of the enricher cable **counterclockwise** to tighten.

11. Install the enricher cable to the new bracket. Tighten the enricher cable nut (4) securely.
12. Install the rubber horn mount (5) onto the enricher bracket (1) with the 5/16-18 flanged locknut from the kit. Tighten the nut to 60-180 **in-lbs** (6.7-20.3 Nm).
13. Obtain the horn and chrome cover assembled earlier. Install the ground wire from the kit to the ground terminal on the horn.
14. Route the ring terminal end of the ground wire to the rear cylinder head top motor mount screw (6). Remove the screw, and slip the ring terminal onto the screw threads. Install the screw, and tighten to 25-30 ft-lbs (34-41 Nm).
15. Position the horn assembly (7) onto the rubber mount (5) stud. Install the lock washer (8) over the stud. Secure the assembly with the acorn nut (9) from the kit. Tighten to 60-180 **in-lbs** (6.7-20.3 Nm).
16. Connect the horn wire terminal clips from the main wire harness to the spade connections on the new horn. Proceed to **Final Assembly**.

## Horn Installation, 1995 Through 2003 Models

1. Cut the cable strap securing the horn wire lead(s) to the frame. Remove the horn wire(s) from the wire bundle. Secure the remaining wires to the frame with a new cable strap (26) from the kit.
2. Route the horn wires, with terminal clips, from the front mounted horn down behind the engine center mounting bracket for later installation to the new side mounted chrome horn kit.
3. Refer to HORN, REMOVAL in the Service Manual and follow the instructions for removing the O.E. front mounted horn assembly for your model.
4. Obtain the 5/16-18 x 3-5/8 in. hex head cap screw (24) from the kit. Install the fuel tank to the vehicle, using the **new** screw and the remaining hardware removed earlier. Refer to FUEL TANK, INSTALLATION in the Service Manual. Tighten the fuel tank front mounting screw to 96-192 in-lbs (10.8-21.6 Nm)

### NOTE

Turn the nut on the back of the enrichener cable **clockwise** to loosen.

5. See Figure 5. Loosen the nut on the back of the enrichener cable. Remove the cable from the slot (3) in the enrichener bracket (1, 1995 through 1998 models) or center engine mount bracket (2, 1999 through 2003 models), and let it hang free.

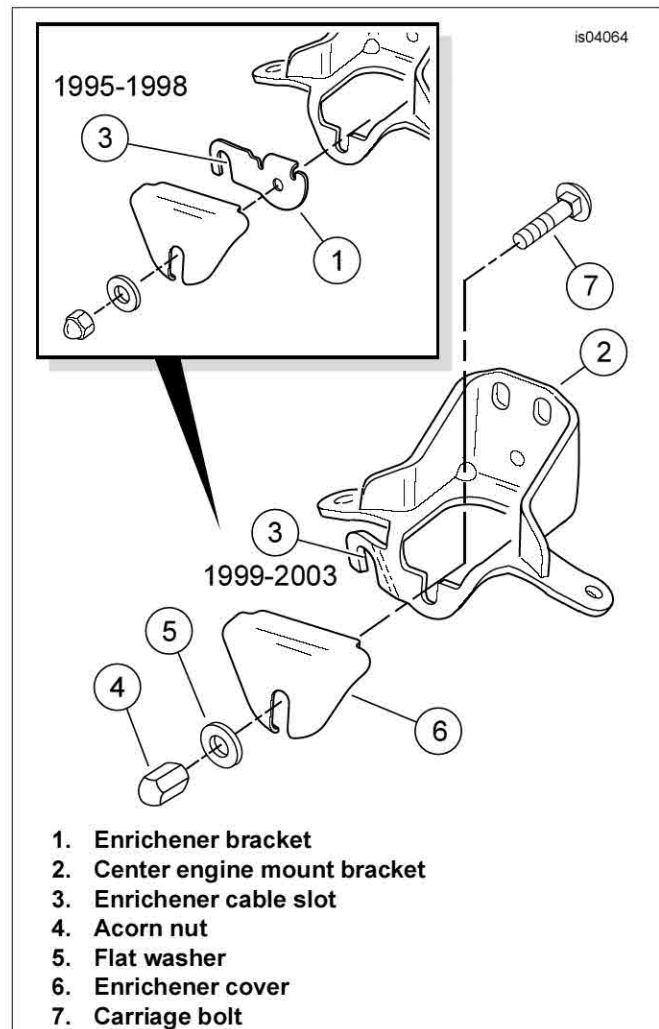
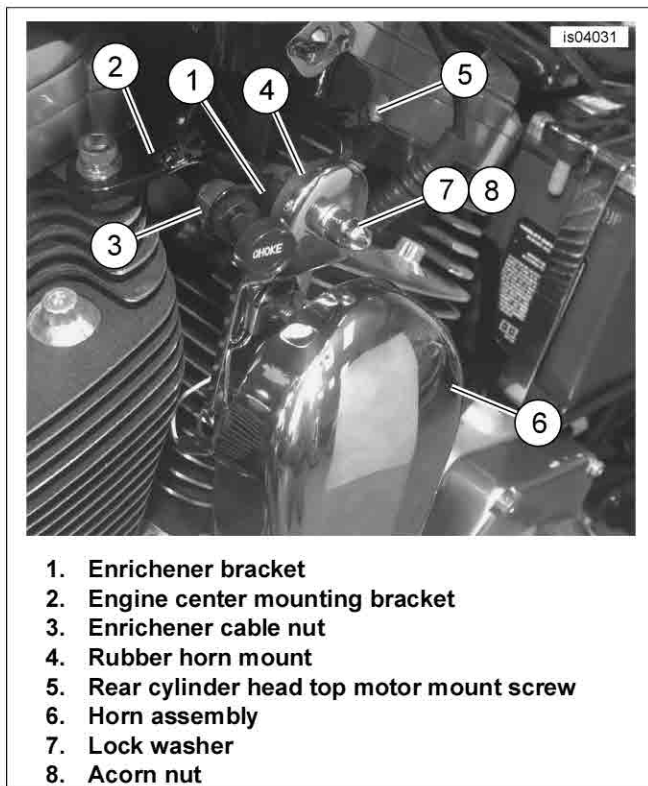

Figure 5. Original Enrichener Bracket, 1995-2003 Models

6. Remove and discard the acorn nut (4) and flat washer (5) retaining the black plastic enrichener cover (6). Discard the cover. Remove and discard the carriage bolt (7), and the enrichener bracket (1) if so equipped.
7. See Figure 10 and Table 1. Obtain the following items from the kit:
  - Rubber horn mount, Item 11
  - 5/16-18 flanged locknut, Item 12
  - Ground wire, Item 13
  - Split lockwasher, 5/16 in., Item 14
  - Acorn nut, high crown, 5/16-18, Item 15
  - **For 1995 through 1998 models:** Enrichener bracket, Item 16.
8. See Figure 6. Position the new enrichener bracket (1), if used, to the engine center mounting bracket (2).



1. Enrichener bracket
2. Engine center mounting bracket
3. Enrichener cable nut
4. Rubber horn mount
5. Rear cylinder head top motor mount screw
6. Horn assembly
7. Lock washer
8. Acorn nut

**Figure 6. Horn Assembly Installation, 1995-2003 Models**

**NOTE**

Turn the nut on the back of the enrichener cable **counterclockwise** to loosen.

9. Install the enrichener cable to the center engine mount bracket (2) or new enrichener bracket. Tighten the enrichener cable nut (3) securely.
10. Install the rubber horn mount (4) onto the center engine mount bracket or enrichener bracket with the 5/16-18 flanged locknut from the kit. Tighten the nut to 60-180 in-lbs (6.7-20.3 Nm).
11. Obtain the horn and chrome cover assembled earlier. Install the ground wire from the kit to the ground terminal on the horn.
12. Route the ring terminal end of the ground wire to the rear cylinder head top motor mount screw (5).  
Remove the screw, and slip the ring terminal onto the screw threads. Install the screw, and tighten to 25-30 ft-lbs (34-41 Nm).
13. Position the horn assembly (6) onto the rubber mount (4) stud. Install the lockwasher (7) over the stud. Secure the assembly with the acorn nut (8) from the kit. Tighten to 60-180 in-lbs (6.7-20.3 Nm).
14. Connect the horn wire terminal clips from the main wire harness to the spade connections on the new horn. Proceed to **Final Assembly**.

**Horn Installation, 2004 Through 2006 Models**

1. Cut the cable strap securing the horn wire lead(s) to the frame. Remove the horn wire(s) from the wire bundle. Secure the remaining wires to the frame with a new cable strap (26) from the kit.

2. Route the horn wires, with terminal clips, from the front mounted horn down behind the engine center mounting bracket (see Figure 7, Items 4 and 5) for later installation to the new side mounted chrome horn kit.
3. Refer to HORN, REMOVAL in the Service Manual and follow the instructions for removing the O.E. front mounted horn assembly for your model.
4. Obtain the 5/16-18 x 4-1/4 in. hex head cap screw (25) from the kit. Install the fuel tank to the vehicle, using the **new** screw and the remaining hardware removed earlier. Refer to FUEL TANK, INSTALLATION in the Service Manual. Tighten the fuel tank front mounting screw to 96-192 in-lbs (10.8-21.6 Nm)

**NOTE**

Turn the nut on the back of the enrichener cable **clockwise** to loosen.

5. See Figure 7. Loosen the nut (1) on the back of the enrichener cable. Remove the cable from the slot in the enrichener bracket (2), and let it hang free.

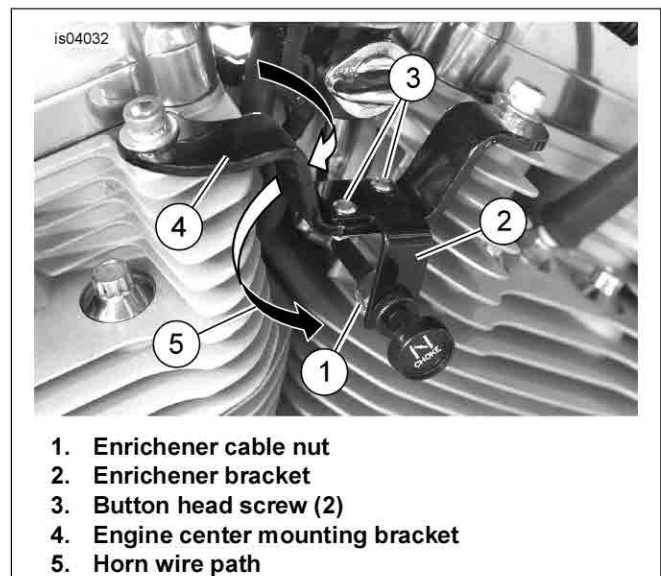

1. Enrichener cable nut
2. Enrichener bracket
3. Button head screw (2)
4. Engine center mounting bracket
5. Horn wire path

**Figure 7. Original Enrichener Bracket, 2004-2006 Models**

6. Remove and discard the enrichener mounting bracket. Save the two button head screws (3).
7. See Figure 10 and Table 1. Obtain the following items from the kit:
  - Rubber horn mount, Item 11
  - 5/16-18 flanged locknut, Item 12
  - Ground wire, Item 13
  - Split lockwasher, 5/16 in., Item 14
  - Acorn nut, high crown, 5/16-18, Item 15
  - Horn and enrichener cable bracket, Item 17
  - (2) 1.12 in (28.4 mm) diameter flat washers, Item 18
8. See Figure 8. Position the new horn and enrichener cable bracket (1) over the engine center mounting bracket, and secure with the two button head screws saved in step 6. Tighten the screws to 36-60 in-lbs (4-7 Nm).

9. Install one of the large diameter flat washers (2) on each threaded stud of the rubber mount (3). Insert a rubber mount stud through the slot in the enrichener bracket, and secure from behind with the 5/16-18 flanged lock nut from the kit. Tighten the nut to 60-180 **in-lbs** (6.7-20.3 Nm).

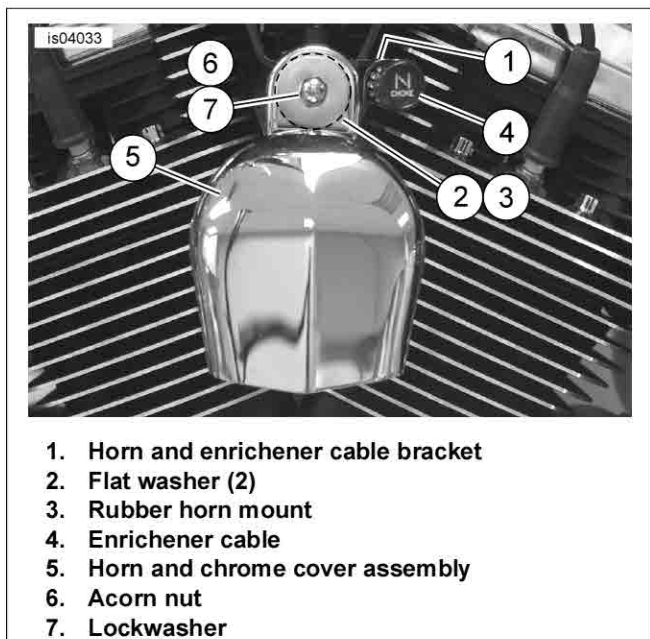

1. Horn and enrichener cable bracket
2. Flat washer (2)
3. Rubber horn mount
4. Enrichener cable
5. Horn and chrome cover assembly
6. Acorn nut
7. Lockwasher

**Figure 8. Horn Assembly Installation, 2004-2006 Models**

#### NOTE

Turn the nut on the back of the enrichener cable **counterclockwise** to tighten.

10. Install the enrichener cable (4) to the enrichener bracket. Tighten the enrichener cable nut securely.
11. Obtain the horn and chrome cover (5) assembled earlier. Install the ground wire from the kit to the ground terminal on the horn.
12. Route the ring terminal end of the ground wire to the rear cylinder head top motor mount screw.  
Remove the screw, and slip the ring terminal onto the screw threads. Install the screw, and tighten to 25-30 ft-lbs (34-41 Nm).
13. Position the horn assembly onto the rubber mount stud. Install the lockwasher (7) over the stud. Secure the assembly with the acorn nut (6) from the kit. Tighten to 60-180 **in-lbs** (6.7-20.3 Nm).
14. Connect the horn wire terminal clips from the main wire harness to the spade connections on the new horn. Proceed to **Final Assembly**.

#### Horn Installation, 2007 and Later Models

1. Cut the cable strap securing the horn wire lead(s) to the frame. Remove the horn wire(s) from the wire bundle. Secure the remaining wires to the frame with a new cable strap (26) from the kit.
2. Route the horn wires, with terminal clips, from the front mounted horn down between the cylinder heads on the left side of the vehicle, for later installation to the new side mounted chrome horn kit.

3. Refer to HORN, REMOVAL in the Service Manual and follow the instructions for removing the O.E. front mounted horn assembly for your model.
4. Obtain the 5/16-18 x 4-1/4 in. hex head cap screw (25) from the kit. Install the fuel tank to the vehicle, using the **new** screw and the remaining hardware removed earlier. Refer to FUEL TANK, INSTALLATION in the Service Manual. Tighten the fuel tank front mounting screw to 96-192 **in-lbs** (10.8-21.6 Nm)
5. See Figure 10 and Table 1. Obtain the following items from the kit:
  - Rubber horn mount, Item 11
  - 5/16-18 flanged locknut, Item 12
  - Ground wire, Item 13
  - Split lockwasher, 5/16 in., Item 14
  - Acorn nut, high crown, 5/16-18, Item 15
  - Horn and enrichener cable bracket, Item 17
  - (2) 1.12 in (28.4 mm) diameter flat washers, Item 18
  - Engine center mounting bracket, Item 19
  - (2) 3/8-16 x 1-1/4 in. long socket head cap screw, Item 20
  - (2) 3/4 in (19 mm) diameter hardened flat washers, Item 21
  - (2) #10-32 x 1/2 in. long button head screw, Item 22
6. See Figure 9. Remove the two button head screws (1) with lock washers found in the cylinder head holes (2).
7. Position the new engine center mounting bracket (3) over the holes, and secure with the two 3/8-16 x 1-1/4 in. long socket head cap screws (4) and hardened flat washers (5) from the kit. Tighten the screws to 17-24 ft-lbs (23.0-32.5 Nm).
8. Position the horn mounting bracket (6) over the engine center mounting bracket, and secure with the two #10-32 x 1/2 in. long button head screws (7) from the kit. Tighten the screws to 36-60 **in-lbs** (4-7 Nm).
9. Install one of the large diameter flat washers (8) on each threaded stud of the rubber mount (9). Insert a rubber mount stud through the slot in the horn bracket, and secure from behind with the 5/16-18 flanged locknut (10) from the kit. Tighten the nut to 60-180 **in-lbs** (6.7-20.3 Nm).
10. Obtain the horn and chrome cover (11) assembled earlier. Install the ground wire from the kit to the ground terminal on the horn.

is04069

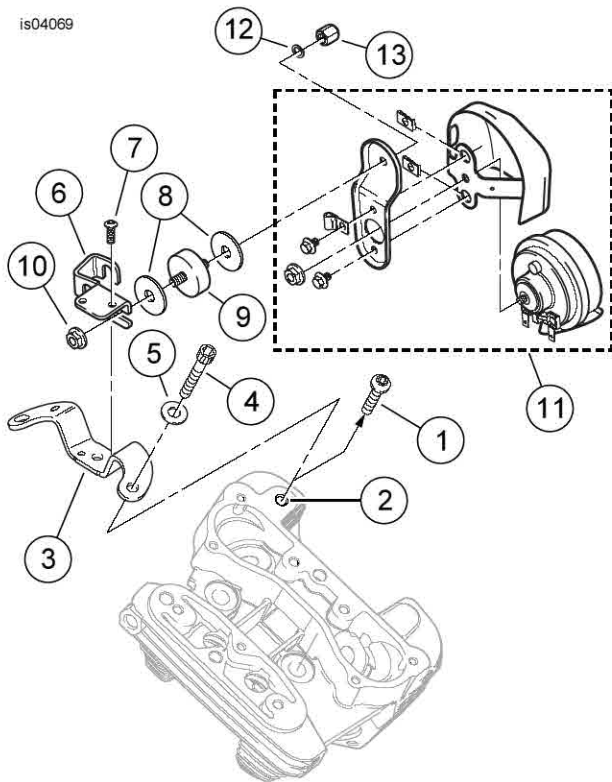

1. Button head screw (2)
2. Cylinder head hole (2)
3. Engine center mounting bracket
4. 3/8-16 socket head cap screw (2)
5. Hardened flat washer (2)
6. Horn mounting bracket
7. #10-32 button head screw (2)
8. Flat washer (2)
9. Rubber horn mount
10. 5/16-18 flanged lock nut
11. Horn and chrome cover assembly
12. Lock washer
13. Acorn nut

11. Route the ring terminal end of the ground wire to the rear cylinder head top motor mount screw.

Remove the screw, and slip the ring terminal onto the screw threads. Install the screw, and tighten to 25-30 ft-lbs (34-41 Nm).

12. Position the horn assembly onto the rubber mount stud. Install the lockwasher (12) over the stud. Secure the assembly with the acorn nut (13) from the kit. Tighten to 60-180 in-lbs (6.7-20.3 Nm).
13. Connect the horn wire terminal clips from the main wire harness to the spade connections on the new horn. Proceed to **Final Assembly**.

Figure 9. Horn Assembly Installation, 2007 and Later Models

## FINAL ASSEMBLY

- Using a cable strap from the kit, secure the excess horn wire to the main wiring harness under the tank.
- Verify that the Ignition/Light Key Switch is turned to the OFF position.

### WARNING

Connect positive (+) battery cable first. If positive (+) cable should contact ground with negative (-) cable connected, the resulting sparks can cause a battery explosion, which could result in death or serious injury. (00068a)

### NOTICE

Do not over-tighten bolts on battery terminals. Use recommended torque values. Over-tightening battery terminal bolts could result in damage to battery terminals. (00216a)

- Apply a light coat of petroleum jelly or corrosion retardant material to the battery terminals. Refer to the Service Manual and follow the instructions given to re-attach the battery cables (positive cable first).
- Test the horn assembly for proper operation.

## SERVICE PARTS

Table 1. Service Parts Table

Item	Description (Quantity)	Part Number
1	Horn, trumpet (includes Item 2)	Not sold separately
2	• Nut, hex flanged, M6-1.0	7495
3	Horn cover assembly (chrome)	61300478
4	Speed nut, 1/4-20 (2)	8108
5	Lockwasher, internal tooth, 5/16 in.	7127
6	Bracket, horn mounting	69120-91
7	Screw, hex head, large serrated flange, 1/4-20 x 3/8 in. long (2)	3563
8	Wire clip, vinyl coated	69062-91A
9	Bracket assembly, horn and enricher cable (for 1992-1994 models)	69027-92
10	Screw, hex socket, button head, 3/8-16 x 5/8 in. long	2916
11	Rubber horn mount	69123-92
12	Locknut, flanged, 5/16-18	7531
13	Ground wire, horn	70087-95
14	Lockwasher, helical spring, 5/16 in.	7041
15	Acorn nut, high crown, 5/16-18	7527
16	Bracket, enricher cable (for 1995-2003 models)	69035-95
17	Bracket assembly, horn and enricher cable (for 2004 and later models)	16355-04
18	Flat washer, 1.12 in (28.4 mm) O.D. (2)	6237
19	Engine center mounting bracket (for 2007 and later models)	16353-04
20	Cap screw, hex socket head, 3/8-16 x 1-1/4 in. long (2)	4748
21	Flat washer, hardened, 0.78 in (19.8 mm) O.D. (2)	6787
22	Screw, hex socket, button head, #10-32 x 1/2 in. long, with lock patch (for 2007 and later models)	3026
23	Cap screw, hex head, 5/16-18 x 3 in. long (for 1992 models)	4086A
24	Cap screw, hex head, 5/16-18 x 3-5/8 in. long (for 1993-2003 models)	4116
25	Cap screw, hex socket head, 5/16-18 x 4-1/4 in. long (for 2004 and later models)	4771
26	Cable strap, double loop (2)	10081
<b>Items mentioned in text, but not included in kit:</b>		
A	Rear cylinder head top motor mount bolt and washer	



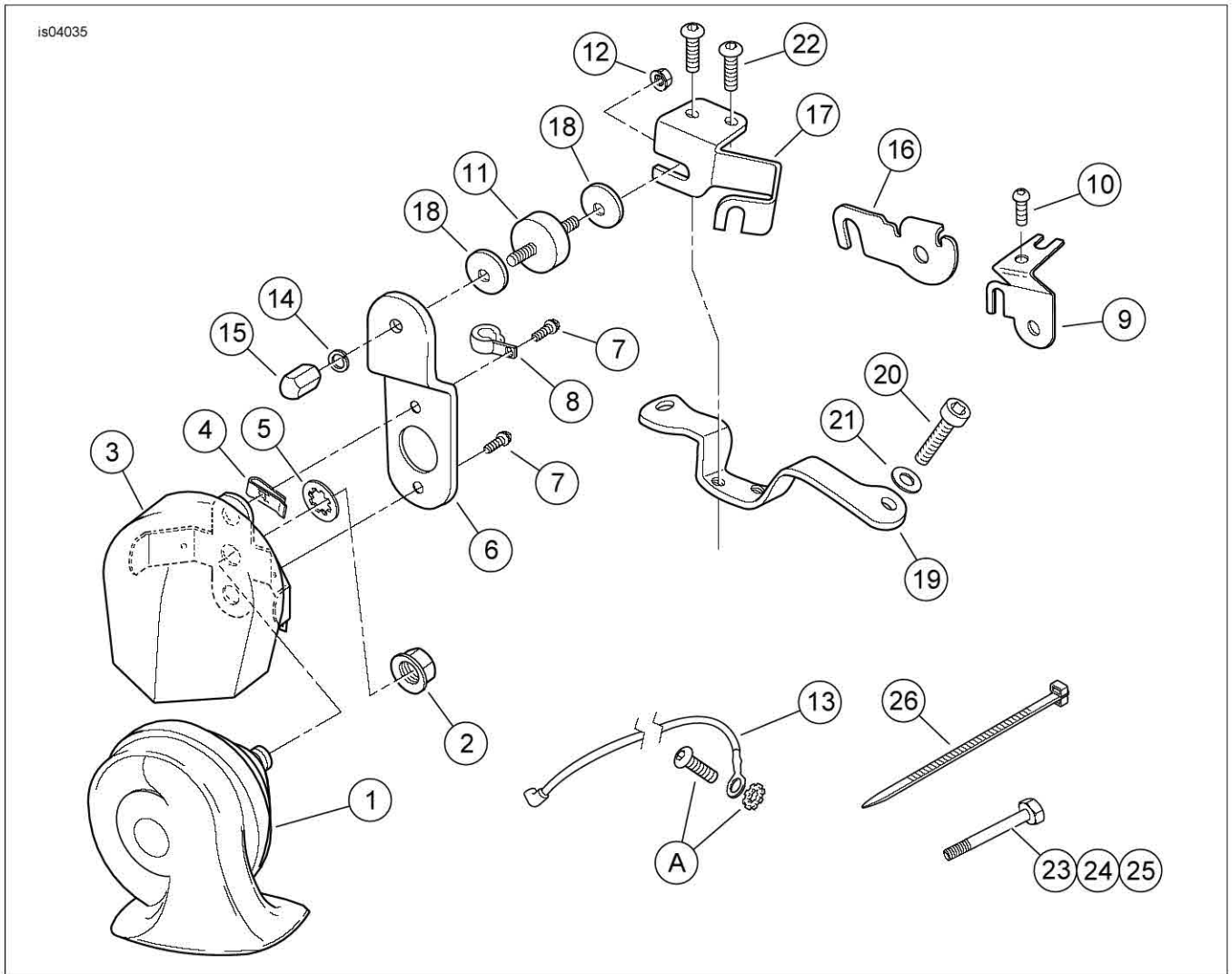

Figure 10. Service Parts, Chrome Horn Kit