



INSTRUCTIONS

-J02962

REV. 10-2-2003

Kit Number 51538-04

XL LOW-PROFILE SOLO SEAT

General

This kit is designed to fit 2004 and later XL 883C and XL 1200C model motorcycles.

See Service Parts Illustration for a list of kit contents.

NOTE

A Service Manual for your motorcycle is available from your Harley-Davidson Dealer.

WARNING

This seat is for solo rider use only. Do not attempt to carry a passenger with this solo seat installed. Use of a luggage rack, fender, or tail section as an additional seat may result in death or serious injury.

Seat Removal

1. Remove the seat according to the directions given in the Owners Manual. Save the seat mounting screw (part number 2952A) for reinstallation with new seat.

Installation of Kit Seat

1. If the original seat was dual type, remove the plastic plug from the front seat mounting hole as shown.
2. See the Service Parts Illustration. Place the retention nut (5) over the cable strap (7) so that the wide end of

the nut rests on the eye of cable strap as shown. Thread the cable strap up under the fender and through the fender hole. Pull up on the cable strap to hold the nut snug against underside of fender.

3. With rib on retention nut seated into notch in fender hole, slide retention washer (6) into place from the rear. This will lock the retention nut in place.

4. **All models:** See Figure 2.

The seat is attached to the vehicle at three points.

- a. The tongue on the front of the seat fits under the rear fuel tank bracket.
- b. The keyhole underneath the seat locks onto the seat post.
- c. The rear mounting bracket attaches to a seat nut in the rear fender with a screw.

Angle the front of the new seat into place so the tongue engages the slot at the rear fuel tank mounting location. Continue to push the seat forward and rotate the rear of the seat downward until the seat contacts the frame. Slide the seat towards the rear so that the keyhole slot on the seat bottom engages with the center seat post on the frame.

It may take some practice to get the seat properly into place. The foam cushioning of the seat will need to be

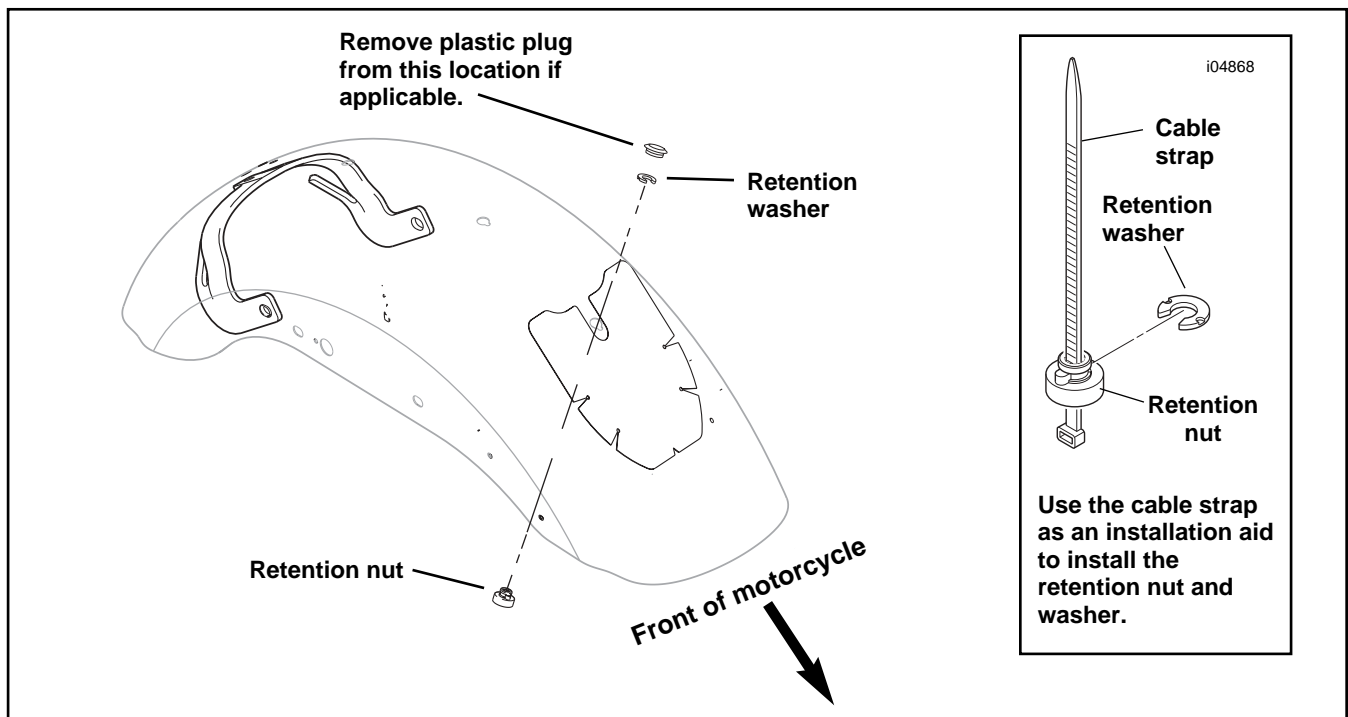

Figure 1.

compressed as the seat is slid forward to get the seat in a forward enough position to engage the post on the frame when the seat is dropped into place and slid rearward.

When properly installed, the front tongue on the underside of the seat should fit snugly in the groove at the fuel tank rear mounting location and the keyhole on the underside of the seat will lock the seat to the post on the frame.

- Pull up on the center of the seat to verify that it is locked into place. (There will be a small amount of play, but the seat should only come up about a half of an inch and then will be held firmly in place by the post on the underside of the seat.)

If the seat is not firmly in place, repeat step 4 until the seat is firmly in place. Reference the Owner's Manual for further instruction on seat placement if needed.

- Install the screw (part number 2952A) and fasten the seat mounting bracket to the top of the rear fender.
- Tighten the mounting bracket screw securely.

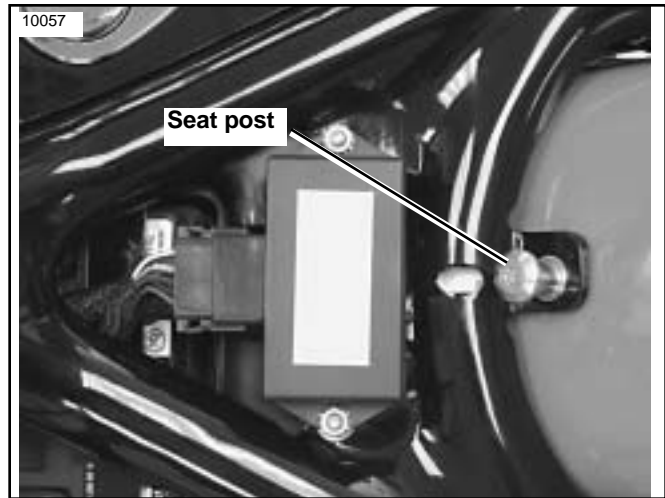

Figure 2. Seat post

- Pull up on the front and rear of the seat again to verify that it is properly secured.

NOTE

The chrome cap is to be installed in rear fender retention nut threads to enhance appearance.

WARNING

After installing seat, pull upward on front of seat to be sure it is in locked position. While riding, a loose seat can shift causing loss of control, which could result in death or serious injury. (00070a)



Service Parts

Part No. 51538-04

Date 7/03

XL Low Profile Solo Seat

i00669b

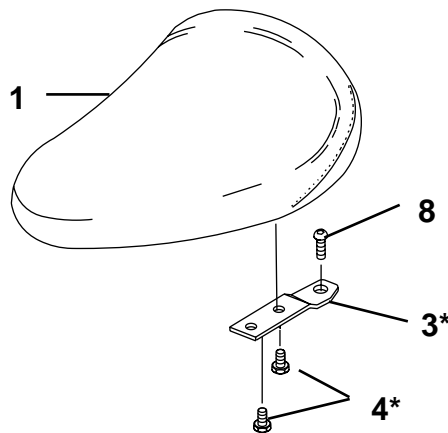

NOTE
Illustration shows a generic styled seat

*The mounting bracket and screws come attached to the seat, but are available separately as service parts.

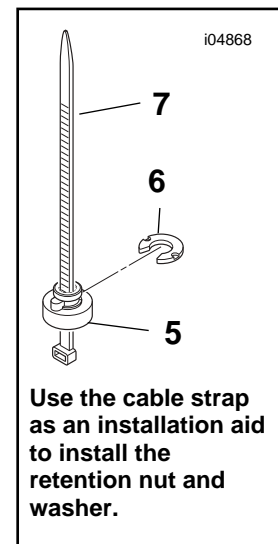

Use the cable strap as an installation aid to install the retention nut and washer.

Item	Description	Part Number	Item	Description	Part Number
1	Solo saddle	Not sold separately	5	Seat retention nut	7488
2	Chrome cap (not shown)	762	6	Retention washer	7489A
3	Mounting bracket	51652-97	7	Cable strap	10039
4	Screws, flange (2)	3588	8	Stock seat mounting screw	2952A