



# INSTRUCTIONS

-J02942

REV. 06-16-03

Kit Number 62999-04

## CUSTOM FUEL TANK INSTALLATION KIT FOR XL 883STD AND 1200R MODELS

### General

#### NOTE

Installation of a custom (larger) tank will require the installation of an XL custom seat. The standard seat on 883STD and 1200R models will not fit properly with the custom (larger) tank.

This kit is designed for the installation of a custom (larger) color-matched tank (purchased separately) on 2004 XL 883STD and 1200R models.

The custom fuel tank is stock on XL 883C and 1200C models.

#### WARNING

A Service Manual is required for correct installation of this kit. The rider's safety depends upon the correct installation of this kit. If the procedure is not within your capabilities or you do not have the correct tools, have your Harley-Davidson Dealer perform the installation. Improper installation of this kit could result in death or serious injury.

#### NOTE

A Service Manual for your model motorcycle is available from your Harley-Davidson Dealer.

### Removal

1. Remove the seat according to the procedure in the applicable Service Manual.

#### WARNING

To prevent accidental vehicle start-up, which could cause death or serious injury, disconnect battery cables (negative cable first) before proceeding. (00048a)

#### WARNING

Disconnect negative (-) battery cable first. If positive (+) cable should contact ground with negative (-) cable connected, the resulting sparks can cause a battery explosion, which could result in death or serious injury. (00049a)

2. Disconnect battery cables, negative cable first.

#### WARNING

Stop the engine when refueling or servicing the fuel system. Do not smoke or allow open flame or sparks near gasoline. Gasoline is extremely flammable and highly explosive, which could result in death or serious injury. (00002a)

3. Remove the fuel tank according to the procedure in the applicable Service Manual.

#### WARNING

Even with the fuel tank completely drained, a small amount of gasoline may leak from the bore when the fuel supply valve is loosened or removed. Thoroughly wipe up any spilled fuel immediately and dispose of rags in a suitable manner. Gasoline can be extremely flammable and highly explosive. Inadequate safety precautions may result in death or serious injury.

4. See Figure 1. Turn the fitting (1) and remove the fuel valve (2), gasket (3) and fuel filter (4). Save the fuel valve and fitting, and discard the fuel filter and gasket.

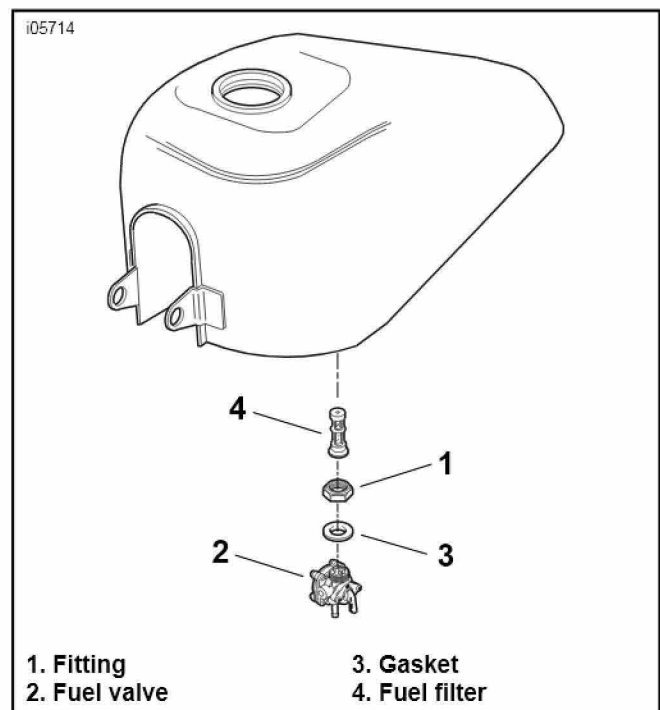

Figure 1. Remove the Fuel Valve

## Installation

1. See Figure 2. Coat the fuel valve threads with LOCTITE® Pipe Sealant with Teflon.

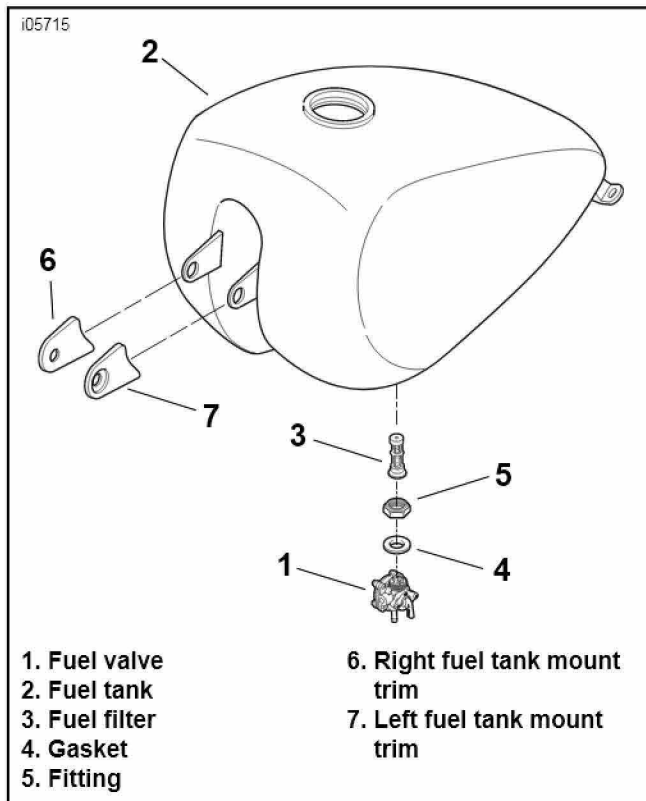

Figure 2. Install the Fuel Valve and Tank Trim

2. Install the fuel valve (1) into the new fuel tank (2), using a new fuel filter (3) and gasket (4) supplied in the kit, and the fitting (5) saved from the old tank.
3. Install the right (6) and left (7) fuel tank mount trim onto the tank front mounting tabs.

## CAUTION

Be sure that wiring harness does not get pinched between fuel tank and frame during tank installation.

4. Install the fuel tank according to the procedure in the applicable Service Manual, using the hardware supplied in the kit:

**Front Tank Mount:** Secure the front tank mount using a 5/16-18 x 4-1/4 in. hex socket screw, two 5/16 in. x 11/16 in. x 1/16 in. flat washers and one 5/16-18 locking flanged nut.

**Rear Tank Mount:** Secure the rear tank mount using a 5/16-18 x 3-1/2 in. hex socket screw, two 5/16 in. x 11/16 in. x 1/16 in. flat washers and one 5/16-18 locking flanged nut.

## WARNING

Connect positive (+) battery cable first. If positive (+) cable should contact ground with negative (-) cable connected, the resulting sparks can cause a battery explosion, which could result in death or serious injury. (00068a)

5. Connect the battery cables, positive cable first.

## WARNING

After installing seat, pull upward on front of seat to be sure it is in locked position. While riding, a loose seat can shift causing loss of control, which could result in death or serious injury. (00070a)

6. Install the seat according to the procedure in the applicable Service Manual.



# Service Parts

Part No. 62999-04

Date 6/03

Custom Fuel Tank Installation Kit for  
XL 883STD and 1200R Models

i05716

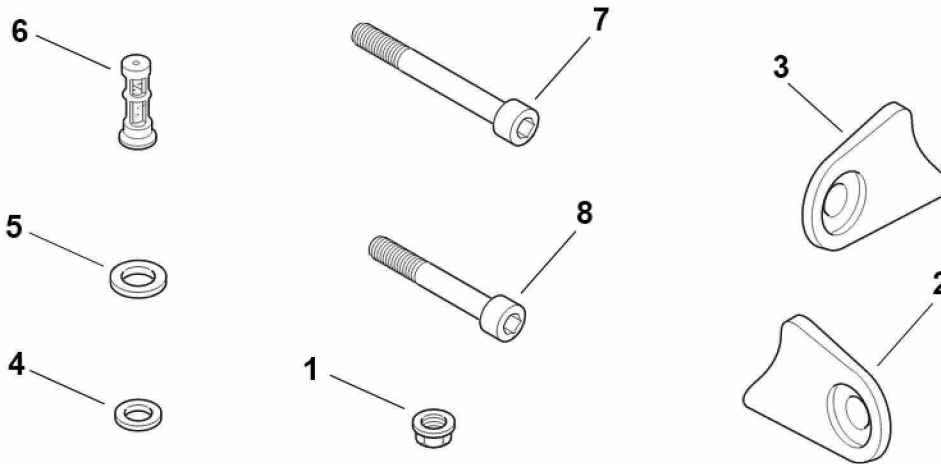

| Item | Description   | Part No. | Item | Description                            | Part No. |
|------|---|----------|------|--|----------|
| 1    | Nut, Flanged, Locking, 5/16-18 (2)                  | 7531     | 5    | Gasket, Fuel Valve                     | 62172-02 |
| 2    | Trim, Fuel Tank Mount, Right                        | 70919-04 | 6    | Filter, Fuel Valve                     | 62166-02 |
| 3    | Trim, Fuel Tank Mount, Left                         | 70903-04 | 7    | Screw, Hex Socket, 5/16-18 x 4-1/4 in. | 4771     |
| 4    | Washer, Flat, 5/16 in x 11/16 in.<br>x 1/16 in. (4) | 6702     | 8    | Screw, Hex Socket, 5/16-18 x 3-1/2 in. | 4758A    |