



INSTRUCTIONS

-J02891

REV. 08-26-2003

Kit Numbers 52187-03, 52188-03, and 52194-03

XL 2-UP CUSTOM SEAT KITS

General

These kits fit all 1983 Through 2003 XL (Sportster®) models.

- Kit 52187-03 is a High-back plain Custom seat
- Kit 52188-03 is a standard plain Custom seat
- Kit 52194-03 is a Low profile plain Custom seat

On models not equipped with passenger footpegs, you must also install Rear Footpeg Kit, part number 49105-83 or 49109-93.

WARNING

Do not install these seat kits on motorcycles that are not equipped with an appropriate grab strap and passenger footpegs. Footpegs and grab strap will help passenger stabilize his/her position while motorcycle is in motion. If footpegs and grab strap are not installed, passenger could fall from moving motorcycle or grab onto operator, causing loss of control of vehicle and death or serious injury.

See the Service Parts illustration for kit contents.

NOTE

A Service Manual for your model motorcycle is available from any Harley-Davidson dealer.

Installation

CAUTION

When performing the following procedures, be careful not to scratch painted surfaces (fender, tank, etc.) with the metal tabs on the seat.

1. See Figure 1. Refer to the Service Manual and follow the instructions given to remove the seat. Retain the rear seat mounting screw, and the Nylon washer on models so equipped.
2. Remove the screw and washer securing the passenger grab strap (if so equipped). Discard the grab strap.
3. Obtain the new grab strap from the kit, and the screw and washer removed in Step 2.

NOTE

1995 and earlier models use a 1/4-28 x 5/8 in. hex head screw to secure the grab strap to the fender. 1996 and later models use a 1/4-20 x 5/8 in. Torx® head screw.

Assemble the washer onto the screw. Insert the screw with washer through the holes in the grab strap.

Insert the screw into the hole in the fender and torque to 36-60 in-lbs (4.1 to 6.8 Nm).

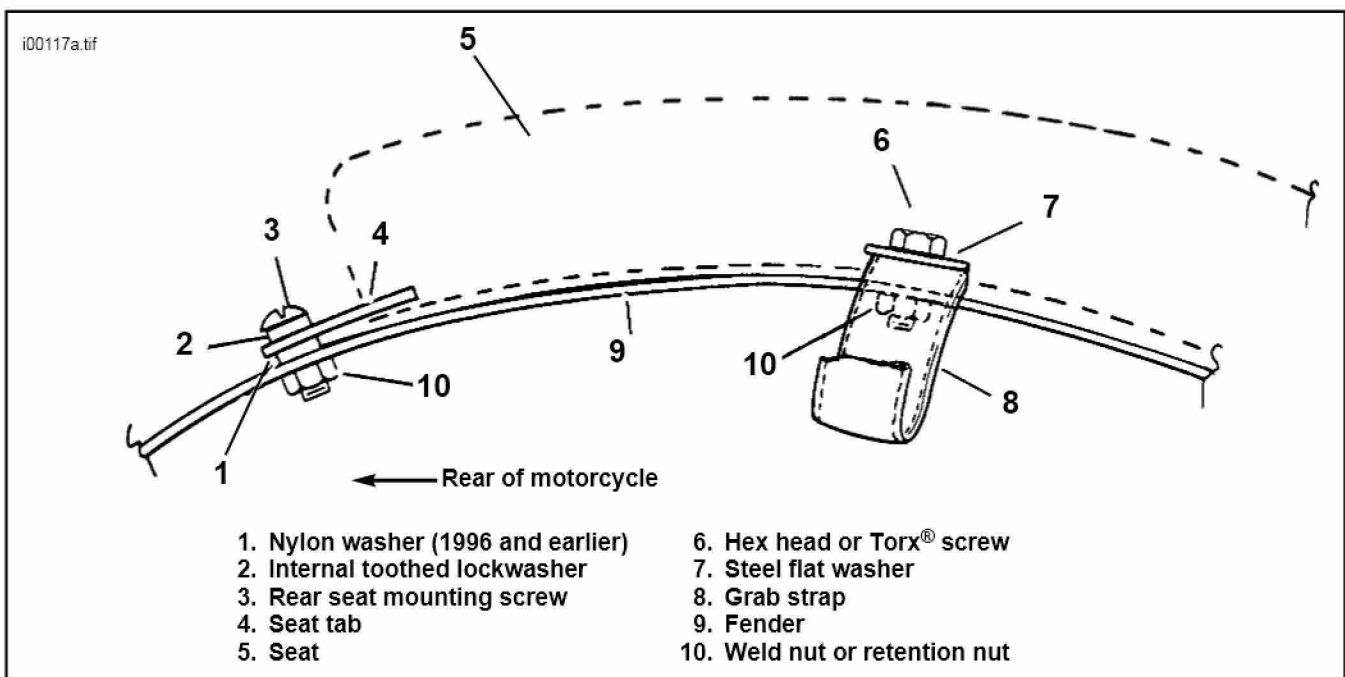

Figure 1. Hardware, Seat Bracket and Grab Strap Assembly

4. For ALL 1996 and earlier models, and 1997 and later models that had a 2-up seat: Proceed to Step 8.

For 1997 and later models that had a solo seat: A retention nut and washer (part number 59768-97) must be installed into the fender hole where the rear seat bracket will be attached. The hole is currently covered with a plastic cap. A cable strap can be used to aid in this installation (see Figure 2).

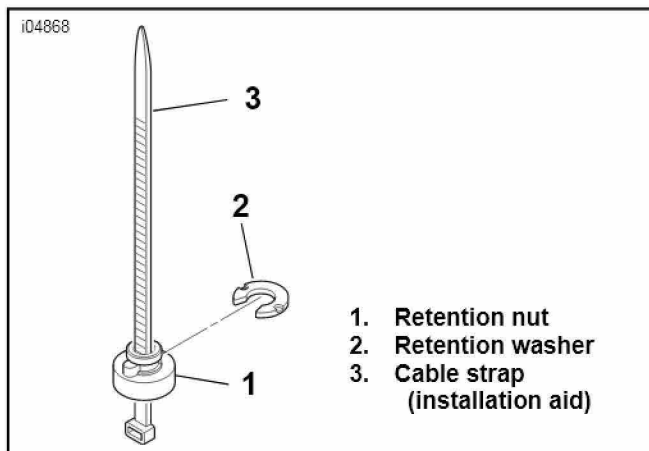

Figure 2. Retention Nut Installation

5. Remove the plastic cap from the hole in the fender where the rear seat bracket will be attached.

6. Place the retention nut over the cable strap so the wide end of the nut rests on the eye of the cable strap. Thread the cable strap up under the fender and through the fender hole. Pull up on the cable strap to hold the nut snug against the underside of the fender.

7. With the rib on the retention nut seated into the notch in the fender hole, slide the retention washer into place from the rear. This will lock the retention nut in place.

8. For 1996 and later models: Slip the rear section of the seat through the grab strap. Bring the seat forward and engage the clip on the bottom front of the seat into the seat bracket on the frame. Secure the seat to the fender using the knurled knob and Neoprene washer from the kit. Install the washer between the seat bracket and fender. Tighten the knob securely.

Remove the adhesive backing from the Bar and Shield emblem and install it in the recess in the knob face.

For 1995 and earlier models: Secure the seat to the fender using the stock rear seat mounting screw removed earlier, and the stock washer (if so equipped). Install the washer between the seat bracket and fender. Tighten the screw securely.

WARNING

After installing seat, pull upward on front of seat to be sure it is in locked position. While riding, a loose seat can shift causing loss of control, which could result in death or serious injury. (00070a)



Service Parts

Part No. 52187-03 & others | Date 08/03

XL 2-Up Custom Seat Kits

i05374a

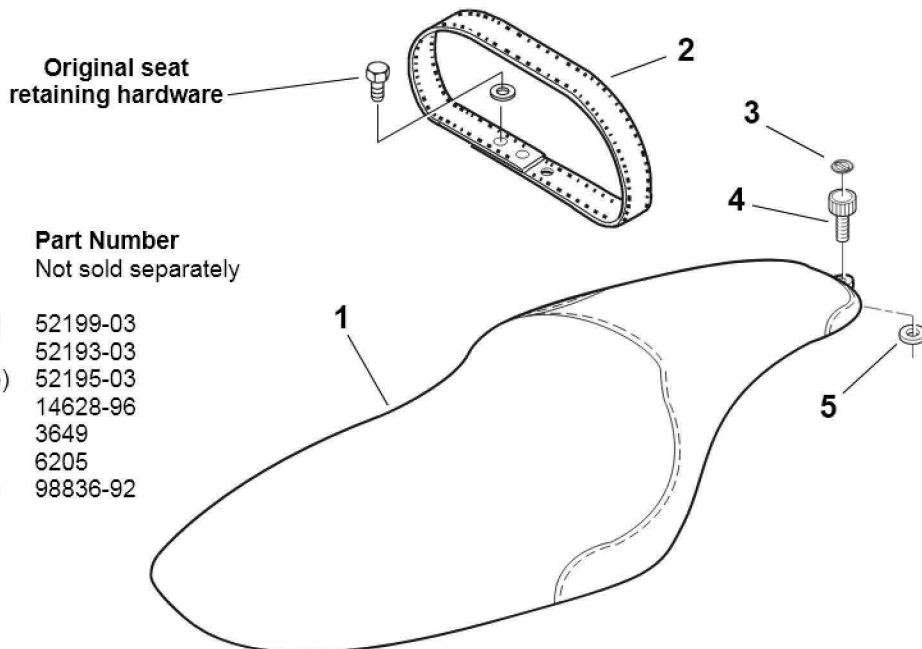

Item	Description	Part Number
1	Seat	Not sold separately
2	Grab strap	Not sold separately
	for Kit 52187-03 (High back)	52199-03
	for Kit 52188-03 (Standard)	52193-03
	for Kit 52194-03 (Low profile)	52195-03
3	Emblem, Bar and Shield	14628-96
4	Knurled knob, 1/4-20	3649
5	Washer, Neoprene	6205
6	Leather dressing (not shown)	98836-92