



INSTRUCTIONS

-J02631

REV. 7-10-02

Kit Numbers 56564-02 and 56579-02

BRAIDED STAINLESS STEEL THROTTLE/IDLE CABLE KIT

General

Kit Number 56564-02 fits 1999-2003 Sportster 883STD, 883C, 1200S and 1200C models.

Kit Number 56579-02 fits 1996 and later FXDWG models.

See the Service Parts Illustration for kit contents.

WARNING

A Service Manual is required to install this kit. The rider's safety depends upon the correct installation of this kit. If the procedure is not within your capabilities or you do not have the correct tools, have your Harley-Davidson Dealer perform the installation. Improper installation of this kit could result in death or serious injury.

WARNING

To protect against shock and accidental start-up of vehicle, disconnect the negative battery cable before proceeding. Inadequate safety precautions could result in death or serious injury.

WARNING

Always disconnect the negative battery cable first. If the positive battery cable should contact ground with the negative cable installed, the resulting sparks may cause a battery explosion which could result in death or serious injury.

NOTE

A Service Manual for your motorcycle is available at your Harley-Davidson Dealer.

Throttle/Idle Cable Removal

CAUTION

Do not remove the switch housing assembly without first placing the 5/32-inch cardboard insert between the brake lever and lever bracket. Removing the switch housing without the insert may result in damage to the rubber boot and plunger on the front stoplight switch.

1. See Figure 1. Place the cardboard insert between the brake lever and lever bracket.
2. See Figure 2. Loosen cable adjuster jam nuts. Screw cable adjusters in until they are as short as possible. This will provide enough slack for easy removal.
3. Using a T25 TORX drive head, remove the right upper and lower switch housing screws.

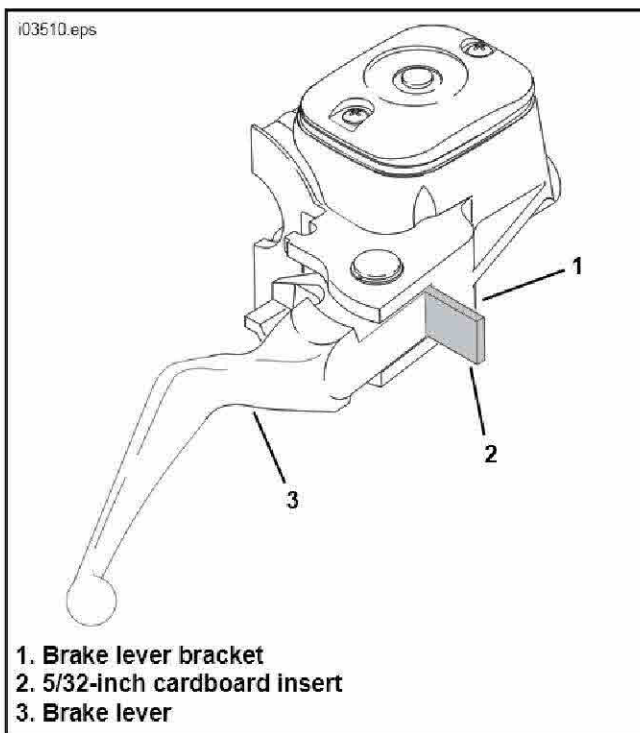

Figure 1. Install Cardboard Insert

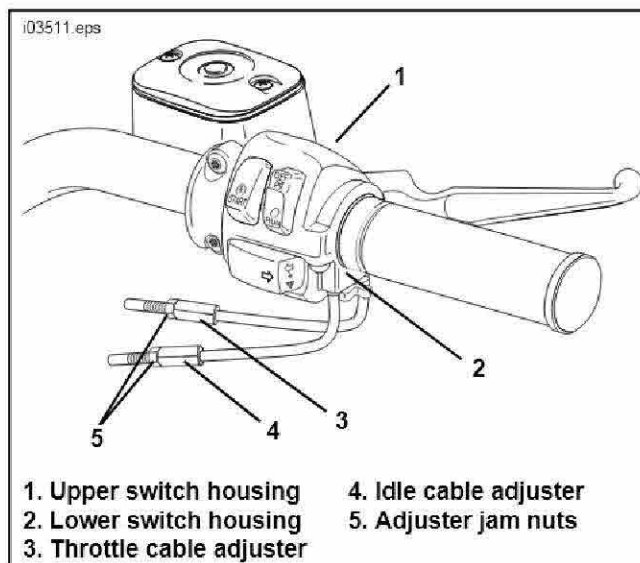

Figure 2. Handlebar Throttle Control

4. Using a T27 TORX drive head, loosen the upper screw securing the handlebar clamp to the master cylinder housing. Remove the lower clamp screw with flat washer.

NOTE

If possible, leave the friction shoe in place. The friction shoe is a loose fit and may fall out or become dislodged if the lower switch housing is turned upside down or shaken.

- See Figure 3. Remove the brass ferrules from the notches on the inboard side of the throttle control grip. Remove the ferrules from the cable end fittings.

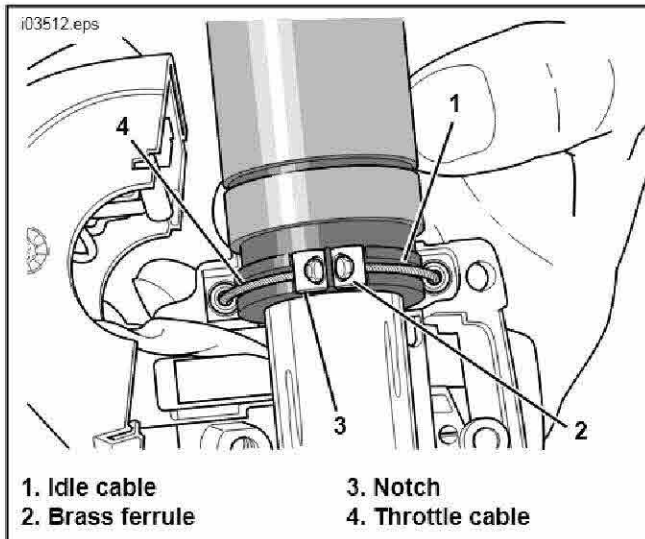

Figure 3. Throttle/Idle Control Cables

- Pull the crimped inserts at the bent tube end of the throttle and idle control cables from the lower switch housing. For best results, use a rocking motion while pulling. Place a drop of light oil on the retaining ring, if necessary, to help in removal. Remove cables from switch housing.
- Follow instructions in the applicable Service Manual and remove air cleaner and backplate.

NOTE

For FXDWG models: It may be necessary to raise the fuel tank to access cables in area of frame backbone. Follow instructions in applicable Service Manual to raise fuel tank.

- See Figure 4. Remove cables at carburetor as follows. Using slots, remove cable barrel ends from holes in throttle wheel and release cable housings from cable guides on carburetor cable bracket.
- If present, cut and discard 1/4-inch cable straps securing cables to frame backbone. Also, if present, cut cable strap securing cable to coil bracket. Remove cables.

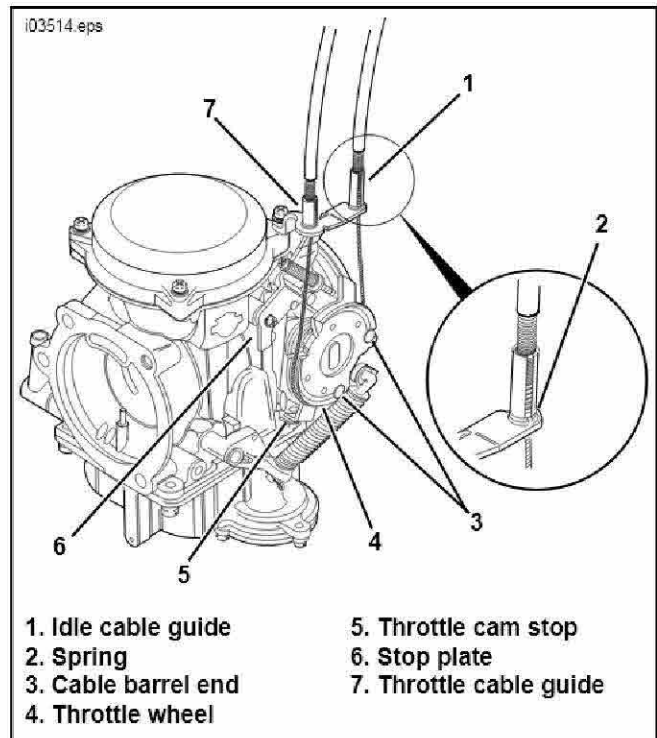

Figure 4. Throttle Cable Assembly (Carbureted Models)

Throttle/Idle Cable Installation

- See Figure 3. Apply graphite lightly to the throttle grip inside the switch housing and on the throttle end of the handlebar.

NOTE

The throttle control cable has a larger-diameter retaining ring crimped to the cable end than does the idle housing cable.

NOTE

For assembly, place a drop of light oil on the retaining rings of the crimped inserts.

- See Figure 5. Push the throttle cable housing and retaining ring into the switch housing larger hole, located in front of the tension adjuster screw.

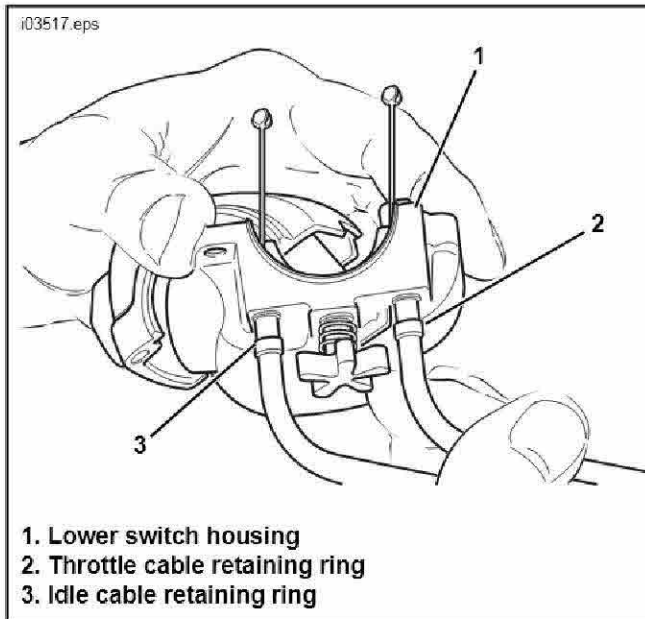

Figure 5. Install Cables to Lower Switch Housing

- Push the idle cable housing and retaining ring into the switch housing smaller hole, located behind the tension adjuster screw.
- Push the throttle and idle control cable housings into the lower switch housing until each snaps into place.

NOTE

If the friction shoe has fallen out or become dislodged, install the shoe with the concave side facing upward and orient so the pin hole is over the point of the adjuster screw.

- Push the throttle control grip over the end of the right handlebar until it bottoms against the closed end. Rotate the grip until the ferrule notches are at the top. To prevent binding, pull the grip back about 1/8 in. (3.2 mm).
- Refer to Figure 3. Position the lower switch housing beneath the throttle control grip. Install two brass ferrules (Part Number 56508-76) from this kit onto cables, seating the ferrules in their respective notches on the throttle control grip. The cables must be captured in the grooves molded into the grip.
- Position the upper switch housing over the handlebar and lower switch housing. Route the wire harness conduit through the depression at the bottom of the handlebar.
- Loosely fasten the upper and lower switch housing screws.
- Position the brake lever/master cylinder assembly inboard of the switch housing assembly, engaging the tab on the lower switch housing in the groove at the top of the brake lever bracket.

- Align the holes in the handlebar clamp with those in the master cylinder housing and loosely fasten the lower screw and flat washer. Position for rider comfort. Beginning with the top screw, tighten the screws to 60-80 in-lbs (6.8-9.0 Nm) using a T27 TORX drive head.
- Torque the lower and upper switch housing screws to 35-45 in-lbs (4-5 Nm) using a T25 TORX drive head.

NOTE

Always tighten the lower switch housing screw first so that any gap between the upper and lower housings is at the front of the switch assembly.

- Remove the cardboard insert between the brake lever and lever bracket.
- Route cables according to the applicable model as described below.

WARNING

Throttle/Idle control cables must not pull tight when handlebars are turned fully to the left or right fork stops. Steering must be smooth and free with no binding or interference. Improperly installed or adjusted cables may lead to loss of vehicle control which could result in death or serious injury.

FXDWG Models – Route throttle cables behind right side of front fork upper bracket, then under right side of tank to carburetor. Secure throttle cables to frame backbone using wire ties provided.

Sportster Models – Route control cables past left side of right turn signal. Loop back through area between headlight and right fork tube. Route rearward under gas tank and secure at clip under ignition switch, then downward to carburetor.

- Refer to Figure 4. Install the carburetor side of the cables as follows. Install the idle cable housing and spring into the longer cable guide on the carburetor cable bracket. Drawing idle cable downward, fit barrel end into hole in throttle wheel (farthest from cam stop). Install the throttle cable housing into the shorter cable guide, inserting barrel end into remaining hole in throttle wheel.
- Tighten cables as necessary to keep barrel ends from dislodging. Verify that cables are seated in channel of throttle wheel. Verify operation by turning throttle grip and observing cable action.
- If loosened, follow instructions in applicable Service Manual and tighten fuel tank hardware.
- Following instructions in applicable Service Manual, install backplate and air cleaner assembly.
- Adjust the throttle and idle cables according to Service Manual instructions.
- Turn the ignition/light key switch on and apply the brake lever to test operation of the brake lamp.

WARNING

Ensure proper brake lamp operation. Visibility is a major concern for motorcyclists. Failure to have proper brake lamp operation may lead to an accident which could result in death or serious injury.



Service Parts

Part No. 56564-02 and 56579-02 | Date 7/02

Braided Stainless Steel Throttle/Idle Cable Kit

104905.eps

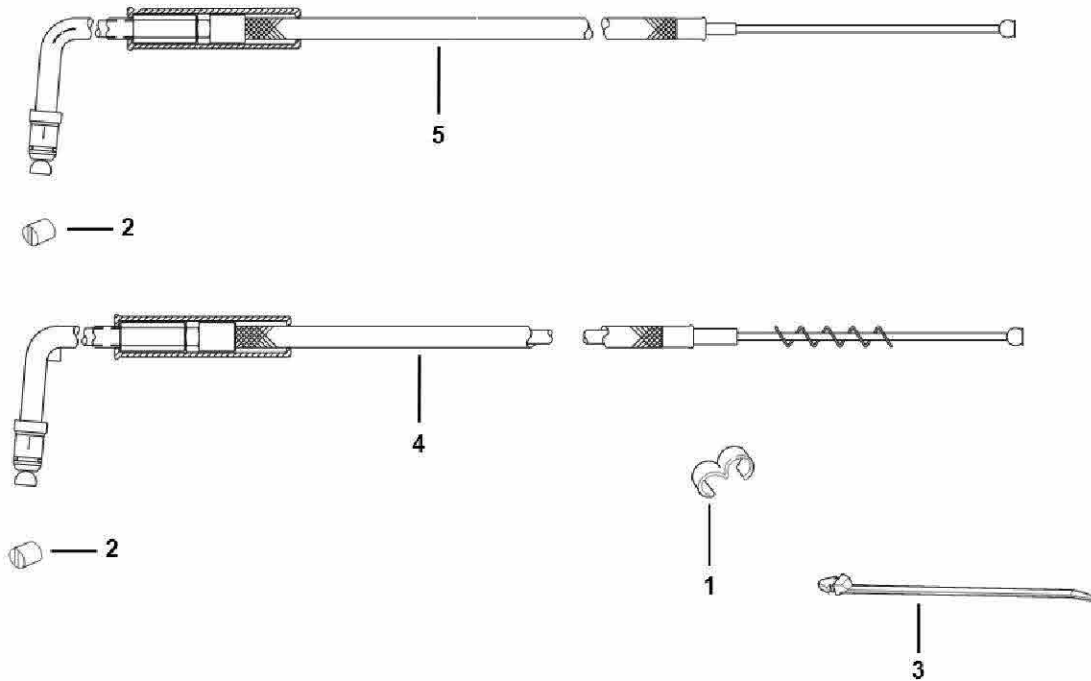

Kit Number 56579-02

Item	Description	Part No.	Item	Description	Part No.
1	Clip, conduit	70514-01	4	Cable, control, idle, braided	Not sold separately
2	Ferrule, control wire (2)	56508-76	5	Cable, control, throttle, braided	Not sold separately
3	Strap, cable (3)	10073			

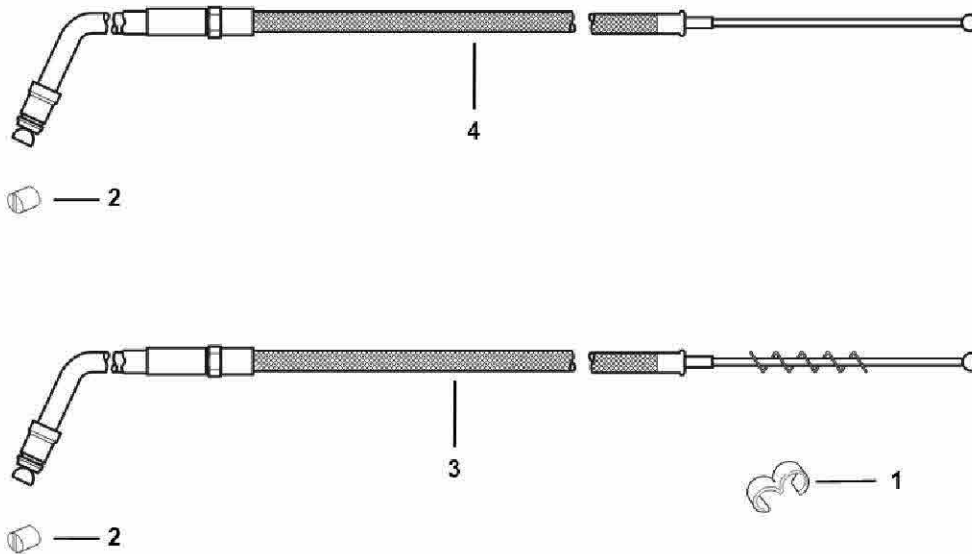

Kit Number 56564-02

Item	Description	Part No.	Item	Description	Part No.
1	Clip, conduit	70514-01	3	Cable, control, idle, braided	Not sold separately
2	Ferrule, control wire (2)	56508-76	4	Cable, control, throttle, braided	Not sold separately