



INSTRUCTIONS

-J01449

REV. 10-11-2004

Kit Numbers 57070-98 (primed kit)

DETACHABLE QUARTER FAIRING AND DOCKING HARDWARE KIT

General

This kit is for installation on 1988 and later XL, FXR and FXD model motorcycles with 39 mm front forks. This kit does not fit XL Custom or FXLR model motorcycles.

This kit must be installed with Docking Hardware Kit Part Number 58164-96. This kit must be purchased separately from your Harley-Davidson Dealer.

See Service Parts Illustration on page 5 for a list of kit contents.

NOTE

A Service Manual for your vehicle is available from your Harley-Davidson Dealer.

Installation

⚠ WARNING

The rider's safety depends upon the correct installation of this kit. Use the appropriate service manual procedures. If the procedure is not within your capabilities or you do not have the correct tools, have a Harley-Davidson dealer perform the installation. Improper installation of this kit could result in death or serious injury. (00333a)

NOTE

If your motorcycle has directional lights mounted on the upper fork bracket they must be relocated to the bottom fork bracket. Some models have front directional lights equipped with three wires, the third black wire is a ground wire. Check to determine how many wires are connected to the front directional lights and follow the following procedure that applies. **If directional lights are not mounted on the upper fork bracket proceed to "ASSEMBLING FAIRING".**

Relocating Two Wire Directional Lights

1. Support motorcycle on a center stand such that front wheel is raised slightly off the ground.
2. Remove fork tube pinch screw from right side of lower bracket.
3. Cut wires connected to right directional light about 2 in. away from directional light body.
4. Remove fork tube pinch screw from right side of upper fork bracket. (This is the screw that secures the right directional light.)
5. Install right directional light on right side of lower fork bracket using pinch screw removed in step 4. Install pinch screw removed in step 2 into right side of upper bracket. Tighten both pinch screws to 30-35 ft-lbs.
6. Repeat steps 1 through 5 to relocate left directional light.

NOTE

Fork tubes may slide downward within fork brackets. If this occurs, front fork tube extension above front fork upper bracket will have to be readjusted according to appropriate Service Manual procedures.

7. Connect the right directional light as follows: Strip approx. 5/16 in. of insulation from the wires cut in step 3.
8. Crimp solderless connectors from kit on two wires coming from motorcycle.
9. Split one end of the 2-conductor polarized wire from kit back about 2 in. and strip 5/16 in. of insulation from wire ends.
10. Slide a piece of shrink tubing from kit over each of the wire ends stripped in step 9 and crimp the wires into the terminals installed in step 8. **Make sure you connect the silver and copper colored wires to like colored wires.**

NOTE

Polarized wire is used in this application to ensure correct wiring. One wire is silver, one is copper colored. Wire colors of spliced wire must match wire color of original directional wire leads.

11. Cut polarized wires to the length required for connection to the wires at the relocated directional light. **Make certain you leave enough slack in wires to allow routing the harness along the fork tube.**
12. Split remaining end of the 2-conductor polarized wire from kit back about 2 in. and strip 5/16 in. of insulation from wire ends.
13. Slide heat shrink tubes over the two wire end.
14. Strip 5/16 in. of insulation from wires connected to directional light and connect like colored wires at directional light with connectors from kit.
15. Slide heat shrink tubing over connectors installed in steps 10 and 14. Activate shrink tubing with heat gun or hair dryer.
16. Position harness along fork tube and secure with cable straps.
17. Repeat steps 7 through 16 for left directional light.
18. Continue at "ASSEMBLING FAIRING".

Relocating Three Wire Directional Lights

1. Support motorcycle on a center stand such that front wheel is raised slightly off the ground.
2. Remove fork tube pinch screw from right side of lower bracket.
3. Carefully cut off 4 in. of conduit covering the wires connected to right directional light.

- Cut the directional light wires at the following lengths from the directional light:

Blue wire- 1-1/4 in. from directional light
Violet wire- 2-1/4 in. from directional light
Black wire- 3-1/4 in. from directional light

NOTE

The wires are cut at different lengths to stagger the butt connectors and prevent a large bulge in the harness.

- Strip 5/16 in. of insulation from the cut ends of the three wires cut in step 4.
- Remove fork tube pinch screw from right side of upper fork bracket. (This is the screw that secures the right directional light.)
- Install right directional light on right side of lower fork bracket using pinch screw removed in step 6. Install pinch screw removed in step 2 into right side of upper fork bracket. Tighten both pinch screws to 30-35 ft-lbs.
- Repeat steps 1 through 7 to relocate left directional light.

NOTE

Fork tubes may slide downward within fork brackets. If this occurs, front fork tube extension above front fork upper bracket will have to be readjusted according to appropriate Service Manual procedures.

- Connect right directional as follows: Crimp solderless connectors from kit on three wires coming from motorcycle.
- Cut a 6 in. length of wire from the black, blue and violet wires in the kit.
- Strip 5/16 in. of insulation from one end on each of the 6 in. wire lengths, connect like colored wires and crimp into connectors installed in step 9.
- Slide shrink tubing from kit over crimped terminals. Activate shrink tubing with heat gun or hair dryer.
- Cut 8 in. of 5/16 in. ID conduit from conduit supplied with kit.
- Slide 8 in. length of conduit onto three wires connected in step 11 and over existing conduit.
- Cut three spliced-on wires to the lengths required for connection to the wires connected to the directional light. Make certain to leave enough slack to allow routing harness along fork tube.
- Slide heat shrink tubes over the three wire ends.
- Strip 5/16 in. of insulation from remaining wire ends and connect like colored wires at directional light with connectors from kit.
- Slide heat shrink tubing over connectors and activate shrink tubing with heat gun or hair dryer.
- Slide 5/16 in conduit, installed in step 14, over all new connections and as close to directional light as possible.
- Install a cable strap on the 5/16 in. conduit, next to directional light, to secure conduit in position.

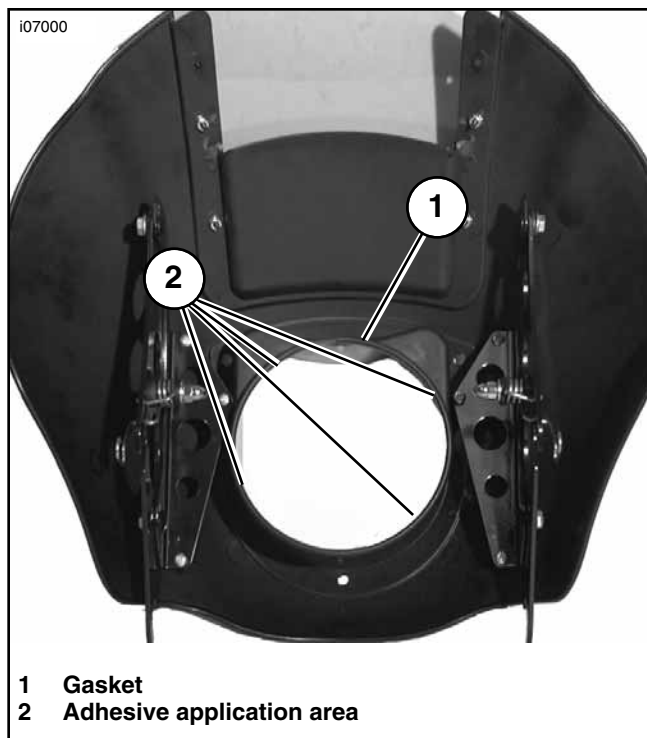

Figure 1. Inner view of fairing

- Position harness along fork tube and secure with cable straps.
- Repeat steps 9 through 21 to connect left directional light.
- Continue at "ASSEMBLING FAIRING".

Assembling Fairing

- See Figure 1. Attach gasket (1) to the edge of the fairing at the headlamp opening as shown. Place the gap in the gasket at the top of the headlamp opening, then trim the gasket to the proper length so that the ends meet.

WARNING

Please observe this warning when applying the adhesive in this kit. EYE IRRITANT. BONDS SKIN IN SECONDS. CONTAINS CYANOACRYLATE ESTER. Avoid contact with skin and eyes. In case of eye or mouth contact, hold eyelid or mouth open and flush with water. Call physician immediately. If fingers become bonded, soak in warm soapy water. Avoid prolonged breathing of vapors. Use with adequate ventilation. KEEP OUT OF THE REACH OF CHILDREN.

- Carefully apply one to two drops of adhesive at areas indicated (2) and to the gasket ends. Glue the ends together. With the gasket installed on the fairing, carefully lift the inside edge of the gasket and apply one drop of adhesive to the gasket and non-painted surface of the fairing as shown.
- Attach left and right mounting brackets (14, 15) to quarter fairing (3) with self tapping screws (10).
- See Figures 2, 3 and Service Parts Illustration. Attach springs (1) to brackets (2) as shown.

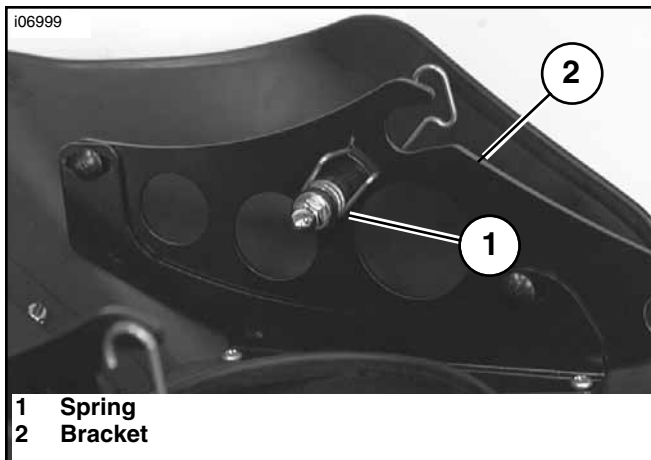

Figure 2. Installed spring

5. See Figure 3. Feed the large hooked end of spring (1) through the slot in the bracket. Slide the spring until coiled portion aligns with the 1/4" hole in bracket. Compress ends of spring together and feed the small hooked end (2) through the same slot that the large hooked end went through. Insert bushings (3) into coiled ends of spring as shown. Line up the spring and bushings with the 1/4" hole and fasten with screw (4), washer (5) and acorn nut (6) as shown.
6. See Service Parts Illustration. Mount attaching brackets (6) to outside face of brackets (14, 15) using shoulder bolt (18) washer (20) and locknut (21). Leave assembly snug to allow for adjustment later.
7. Place wellnuts (16) into fairing (3) and attach headlight cover (7) with washers (4) and screws (2).
8. Remove the backing to the adhesive backed pads (23) and attach them in the locations shown. Two pads are placed on the upper corner of the fairing in the windshield recess and two pads are placed on the inner surface of the windshield in the bottom corners.
9. Attach windshield (1) to fairing using the 4 gaskets (19) along with screws (2), washers (4) and nuts (22). The windshield can be positioned in two different locations. The upper position allows air to pass through fairing creating a more open feel when riding. To change positions, remove screws and rotate the gaskets (19) to plug the unused holes and reinstall the windshield and screws.

Installing Quarter Fairing

NOTE

Cover gas tank and front fender before beginning installation to prevent scratching.

1. See Figure 4. Relocate clutch cable (1) to the inside of the handlebars (2) as shown in illustration as follows:
 - a. See Figure 5. Slide rubber boot (1) off cable adjuster (2). Adjuster is located approximately halfway along clutch cable by the front frame downtube.
 - b. Holding cable adjuster with 1/2 inch wrench, loosen jam nut (3) using a 9/16 inch wrench. Back jam nut away from cable adjuster. Move adjuster toward jam nut to introduce a large amount of freeplay at the hand lever.

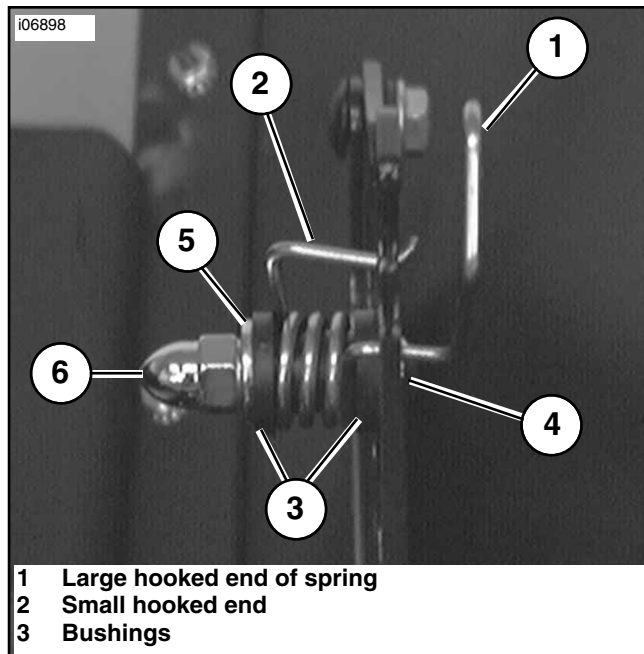

Figure 3. Rear view of installed spring

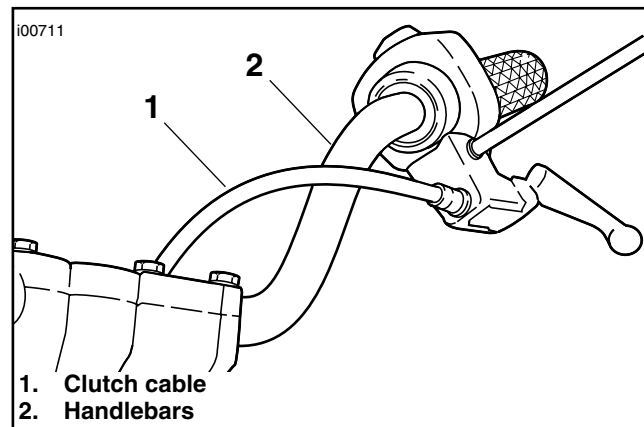

Figure 4. New Clutch Cable Routing

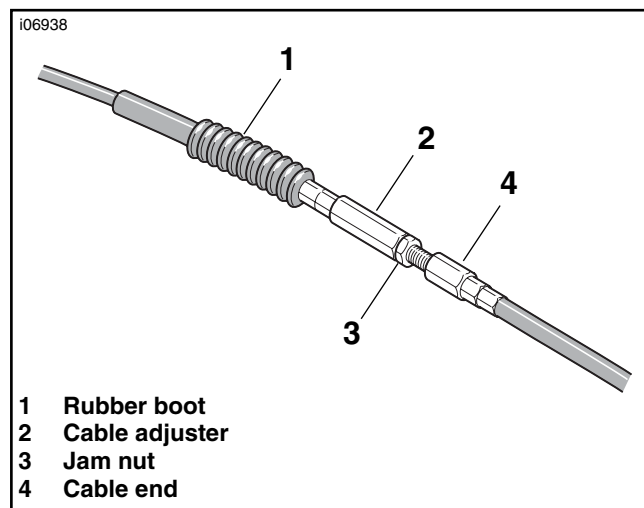

Figure 5. Clutch cable adjustment

- c. Remove small snap ring from pivot pin groove at bottom of clutch lever bracket. Remove pivot pin and clutch hand lever from bracket.
- d. Reroute clutch cable to the inside of the handlebars as shown in Figure 4 and reconnect clutch cable to clutch lever by reversing step c.

- e. See Figure 6. Turn cable adjuster away from jam nut until slack is eliminated at hand lever. Pull clutch cable ferrule away from clutch lever bracket to check free play. Turn cable adjuster as necessary to obtain 1/16 to 1/8 inch (1.6-3.2 mm) free play (1) between end of cable ferrule and clutch lever bracket.
- f. Hold adjuster with 1/2 inch wrench. Using 9/16 inch wrench, tighten jam nut against cable adjuster. Cover cable adjuster mechanism with rubber boot.

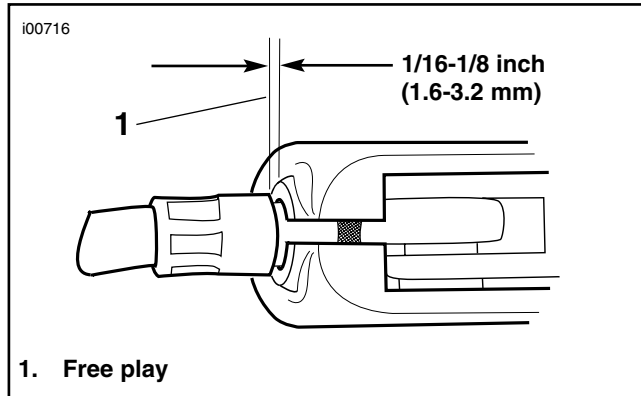

Figure 6. Clutch Cable Adjustment

2. See Figure 7 and Service Parts Illustration on page 6. **For handlebar styles other than buckhorn pullbacks**, use wireform (1) (item 1 on Service Parts, sheet 6) included in hardware kit part number 58164-96 to secure throttle cables to upper mounting clamp as shown. Place chrome washer (2) from hardware kit (item 6 on Service Parts, sheet 6) between wireform and mounting clamp nut.

See Service Parts Illustration on page 6. **For buckhorn-style pullback handlebars**, use wireform (1) included in kit to secure throttle cables to upper fork triple clamp as shown. Use sockethead screw (8) and washer (6) contained in hardware kit, and place washer under wireform.

WARNING

After securing throttle cable with wireform, check that throttle control opens and closes smoothly when handlebars are turned fully to left and right fork stops. A sticking throttle could result in loss of control of the vehicle and possible personal injury.

3. See Service Parts Illustration. Assemble mounting hardware for lower fairing mounting as shown. Locate assemblies approximately 1/2 inch from lower fork triple clamp with clamp nuts facing rear of motorcycle. Tighten clamp nuts to 10 ft-lbs (14 Nm). Be sure the clamp does not rotate during tightening (the mounting bushing must be parallel to the fairing brackets). Tighten buttonhead screws (4) to 15 ft-lbs (20 Nm).
4. Hook the two lower quarter fairing assembly "jaws" into the grooves of the lower bushings then slide the upper clamp assemblies into place until the upper bushings firmly fit into the upper fairing "jaws".
5. With quarter fairing in place, tighten upper clamp nuts to 10 ft-lbs (14 Nm). Be sure the clamp does not rotate during tightening (the mounting bushing must be parallel to the fairing brackets).

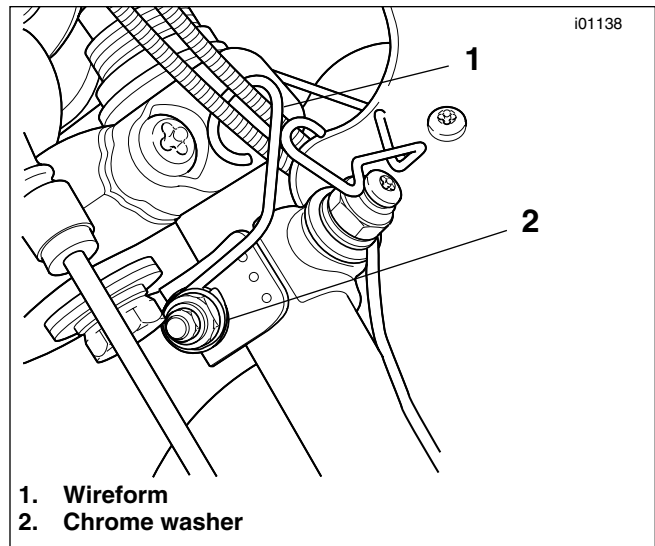

Figure 7. Throttle Cable Attachment on all handlebars except buckhorn-style

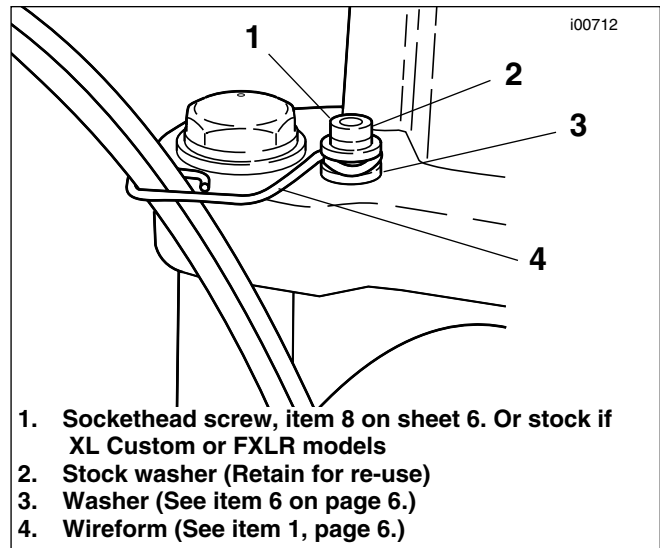

Figure 8. Throttle Cable Attachment on Buckhorn style pullback handlebars

6. Align fairing with headlight and tighten nuts (21) on the adjustable brackets (6, 14, 15). When tight, verify function of detachable feature by grabbing the fairing and pulling forward and upward to remove. If brackets or clamps slide or rotate during removal, realign and retighten all fasteners.

NOTE

Inspect fairing for proper adjustment in relation to the headlamp opening. If necessary, adjust the mounting clamps up or down for proper headlamp to fairing relationship.

7. If front signal lights were relocated, test operation of turn signals and running lights. If operation is not correct, verify that the wire splices were made properly.

WARNING

Inspect fairing upon completion of installation. Be sure fairing mounting does not restrict full left or full right movement of front fork assembly. Restricted movement could affect handling, resulting in personal injury. If restriction does occur, adjust fairing as needed until proper clearance is obtained.

WARNING

Check mounting hardware periodically. Never ride with loose mounts. A loose mounting causes extra stress on all other mounts, as well as the fairing itself, and could result in premature failure of components allowing the fairing to detach and startle rider. This could cause loss of control and personal injury.

Care and Cleaning

NOTE

Sunlight reflections off of the inside curvature of a windshield can, at certain times of the day, cause extreme heat build-up on motorcycle instruments. Exercise care in parking. Park facing the sun, place an opaque object over the instruments, or adjust the windshield to avoid reflections.

CAUTION

Do not clean Lexan® polycarbonate in hot sun or high temperature. Powdered, abrasive or alkaline cleanser will damage the windshield. Never scrape the windshield with a razor blade or other sharp instruments because permanent damage will result.

CAUTION

Harley-Davidson windshields are made of Lexan. Lexan is a more durable and distortion-resistant material than other types of motorcycle windshield material, but still requires attention and care to maintain. Failure to maintain Lexan properly can result in damage to the windshield. (00230a)

CAUTION

Do not use harsh chemicals including rain sheeting products on Harley-Davidson windshields. They can cause dulling or hazing. If you want to use a windshield protectant on your windshield, try Harley Glaze Polish and Sealant (00231a)

CAUTION

Do not use benzine, paint thinner, gasoline or any other type of harsh cleaner on the windshield. Doing so will damage the windshield surface. (00232a)

- Do not use benzine, paint thinner, gasoline, lubricants (including Armorall®), or other cleaning agents on the rubber bushings. They will damage the bushing surfaces.

NOTE

Covering the windshield with a clean, wet cloth for approximately 15 minutes before washing will make dried bug removal easier.



Service Parts

Part No. 57070-98

Date 10/04

Detachable Quarter Fairing Kits

sp57070-99

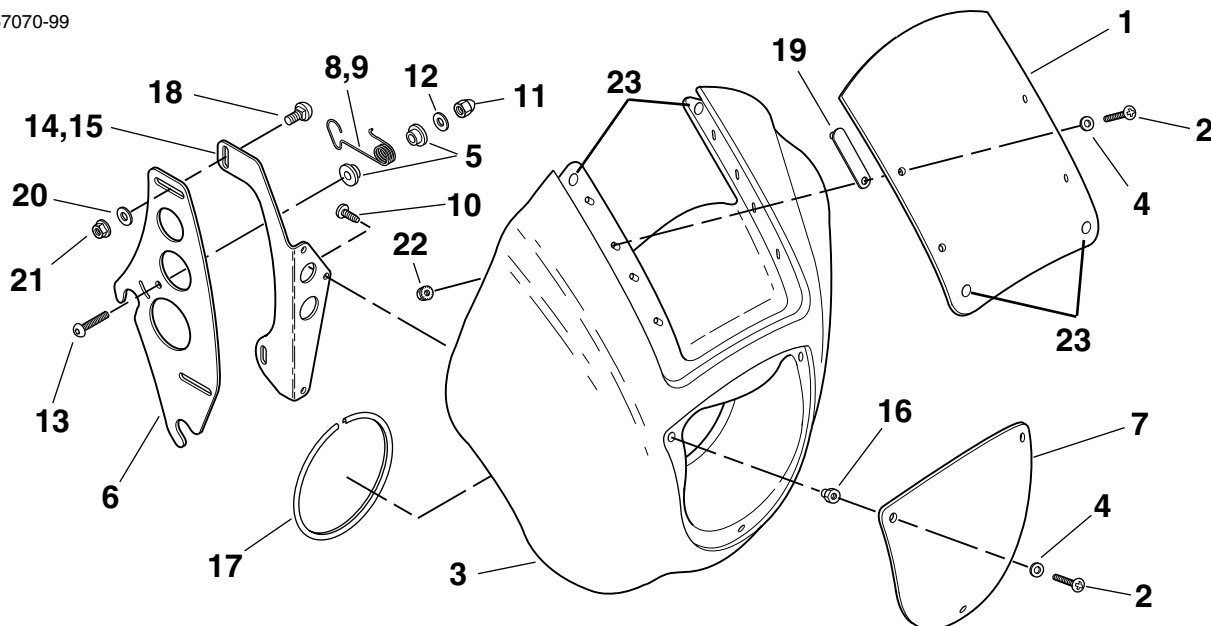

Item	Description	Part No.	Item	Description	Part No.
1	Windshield	57074-98	12	Flatwashers (2)	6703
2	Buttonhead screws (7)	982	13	Buttonhead screws (2)	94426-95
3	Quarter Fairing (primed)	57077-98	14	Bracket, left, <i>not shown</i>	57071-98
4	Washers (7)	6276	15	Bracket, right	57072-98
5	Nylon bushings (4)	58272-95	16	Well nut (3)	5210
6	bracket (2)	57073-98	17	Gasket, edge	52428-99
7	Headlight cover	57075-98	18	Bolt, 1/4-20 carriage (4)	5403B
8	LT wireform, <i>not shown</i>	58579-96A	19	Gasket, trim (4)	57076-98
9	RT wireform	58580-96A	20	Washer (4)	6424
10	Screw, tapping (6)	5209	21	Nut, flange 1/4-20	7981
11	Acorn nuts, 1/4-20 (2)	94004-90T	22	Nut, keps #6-32 (4)	7979
			23	Pads, adhesive backed (4)	57078-99



Service Parts

Part No. 58164-96

Date 10/04

Windshield Docking Hardware Kit

sp58034-3a

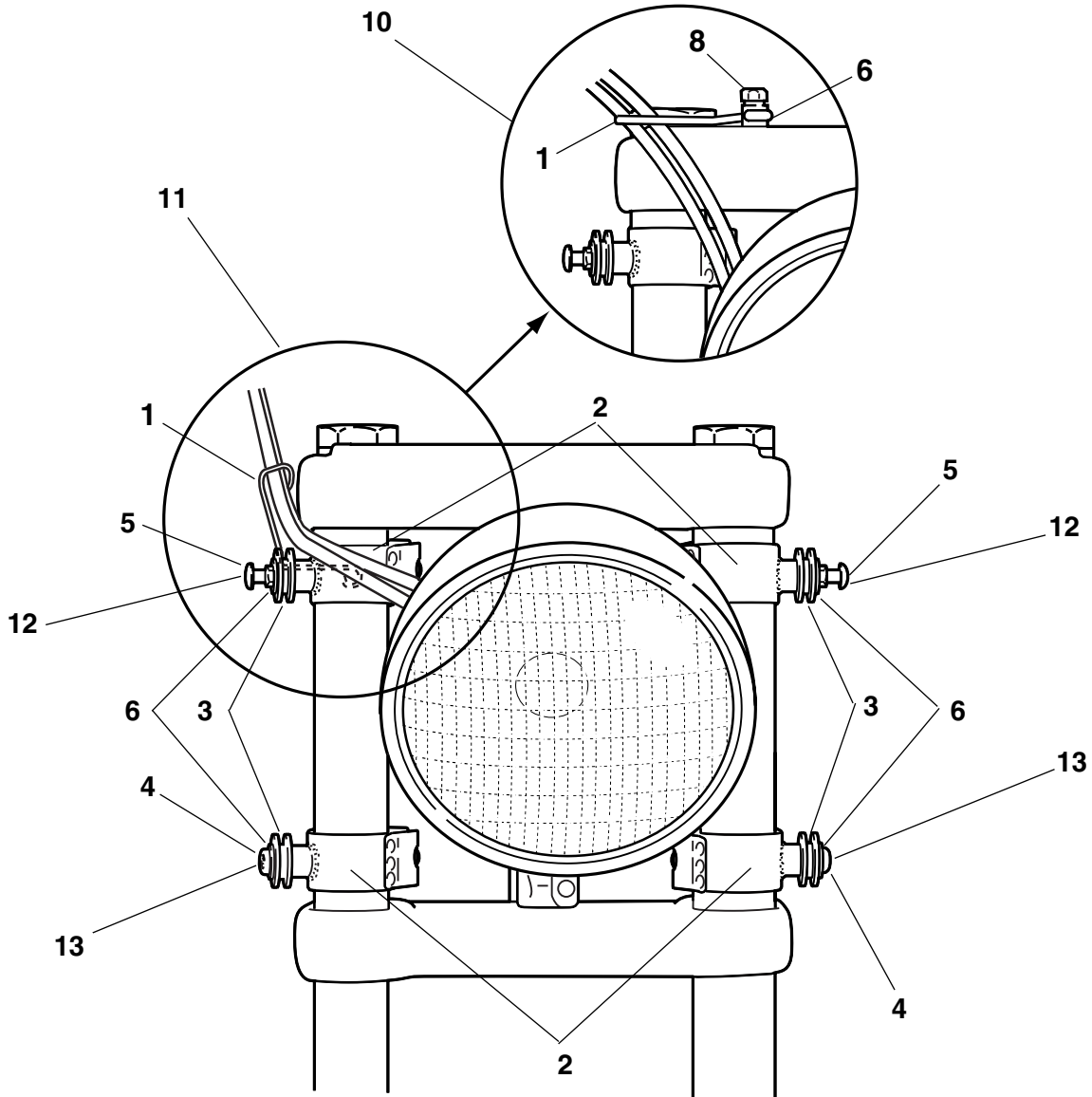

Item	Description	Part No.	Item	Description	Part No.
<i>Hardware kit (58164-96):</i>					
1	Wireform	58558-97	6	Flatwasher, chrome (5) (use with wireform, item 1)	94066-90T
2	Mounting clamp (4)	58124-96	7	Turn signal relocation kit (not shown)	72389-96
3	Bushings (4)	67621-94	8	Sockethead screw, 5/16-18 x 1.25 long	3210
4	Buttonhead screw (2), 5/16-24 x 5/8 long	94468-94T	9	Cable straps (4), <i>not shown</i>	10006
5	Mushroom fastener (2)	58172-96			

NOTE:

- 10 Wireform location and throttle cable routing for buckhorn-style pullback handlebars.
- 11 Wireform location and throttle cable routing for handlebar styles other than buckhorn-style pullbacks.
- 12 Upper windshield mounting.
- 13 Lower windshield mounting.