



# INSTRUCTIONS

-J01423

REV. 3-31-99

Kit Number 62874-99

## SPORTSTER VERTICAL MOUNT OIL COOLER KIT

### General

This kit is designed for installation on 1982 and later Sportster model motorcycles.

See *Service Parts Illustration* for a list of kit contents.

### CAUTION

All oil coolers and lines are installed in the part of the oil flow loop that returns engine oil to the oil tank. The oil cooler outlet must direct oil flow into the return to the oil tank. If oil is not directed into the return to the oil tank, engine damage could occur.

### NOTE

*Flow through the heat exchanger can be either way.*

Although the cooler must be in the oil flow return loop, it can be installed either before or after the oil filter.

This instruction sheet explains how to install the oil cooler before the filter on 1985 and earlier model Sportsters and after the filter on 1986 and later model Sportsters.

Carefully layout and measure oil lines before cutting the bulk oil line in this kit. The approximate lengths given in this Instruction Sheet can vary slightly from motorcycle to motorcycle because of individual variations of accessories.

### CAUTION

- Connect all oil lines properly or oil loss can cause engine damage.
- Installing oil cooler systems will require adding 1/2 to 1 pint of oil. Check oil supply before operating motorcycle. Fill up to, but not above, upper mark on dipstick.
- For motorcycle operation in temperatures below 50°F, use thermostat kit part number 62878-99 to allow the engine to warm up to normal operating temperature.
- Failure to follow procedures could result in engine damage.

### Installation- Mounting Oil Cooler

On all models, begin the kit installation by mounting the oil cooler to the left frame downtube, in accordance with the following instructions. Hose hook-up and routing differs for the various models. Follow the instructions that apply to your motorcycle.

### NOTE

*On all 1991 and later XLH models, the reflector on the left front frame downtube may interfere with the oil cooler installation. See *Service Parts Illustration*.*

### WARNING

Federal Motor Vehicle Safety Standard (FMVSS) 108 requires all motorcycles to be equipped with side reflectors. If the reflector must be removed from the left front frame downtube, make sure to install the reflector from the kit onto the left side of the oil cooler as shown in the *Service Parts illustration*. Loss of visibility to other motorists could result in an accident, and death or serious injury.

### CAUTION

Oil cooler must be mounted below frame weldment, or oil cooler damage may occur when clamps are tightened.

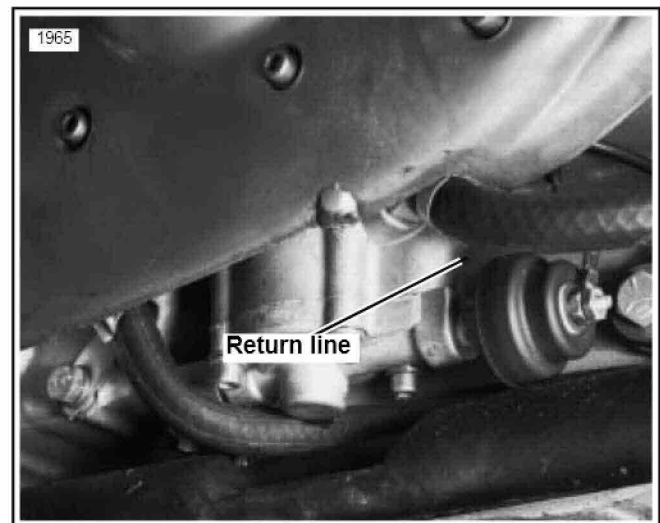

Figure 1. Oil Pump Hose Identification - 1982 to 1985

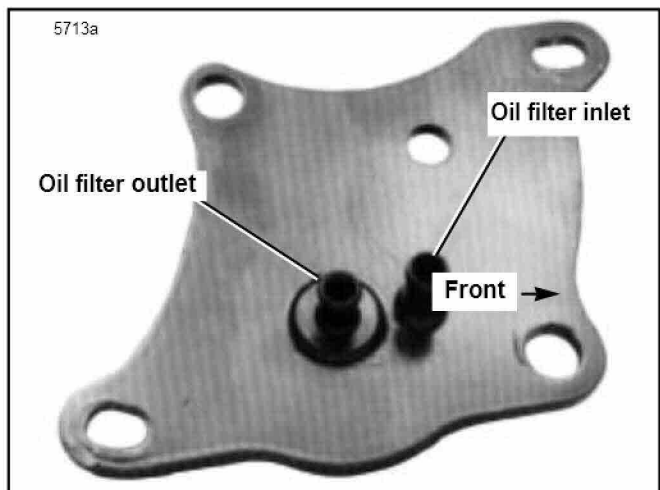

Figure 2. Oil Filter Fittings - 1982 to Early 1984 (Generator Equipped)

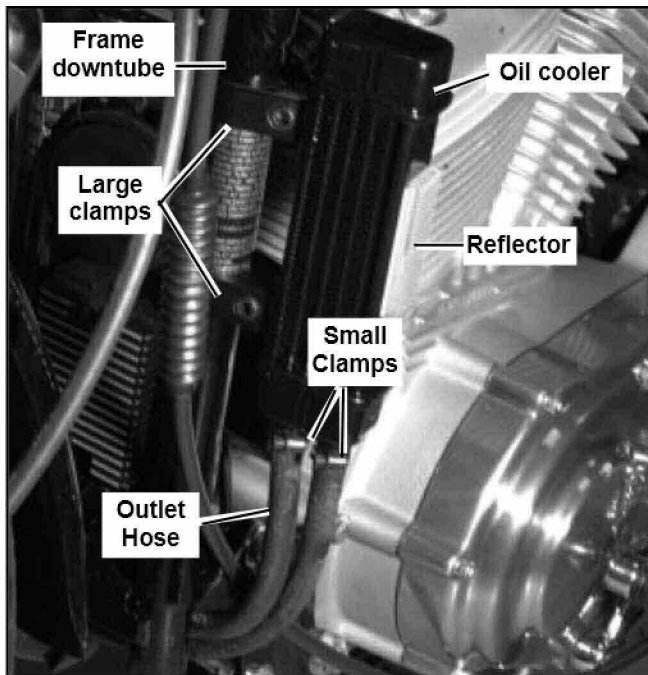

Figure 3. Oil Cooler Mounting (Typical)

### Removing and Installing Hoses- 1982 to Early 1984 Models (Generator Equipped)

1. See Service Parts illustration. Cut two sections of hose (3), one approximately 9 in. long and one approximately 14 in. long.
2. See Figures 1 and 2. Disconnect the oil return line at the oil pump and oil filter inlet. Use a pan to catch any oil that may spill.
3. See Figures 1 and 3. Connect 14 in. hose to oil pump return fitting. Route hose forward and through hole in right front engine mount and up to oil cooler inlet fitting. Secure connections with clamps from kit.
4. See Figures 2 and 3. Connect 9 in. hose to inlet fitting on oil filter mount and outlet fitting on oil cooler. Secure with clamps from kit.

#### CAUTION

- Tie wrap oil line(s) to upper, inside of frame tube to prevent oil line(s) from hanging outside, below frame tubes. Do not over-tighten tie wraps. Over-tightening could collapse hose, restrict oil flow and cause engine damage. Clip off tie wrap loose ends.
  - Do not route hose below frame tubes or hose could be damaged by debris.
5. Start and run engine. Check all connections, clamps and hose fittings for oil leaks. Add oil if necessary.

### Removing and Installing Hoses - Late 1984 to 1985 Models (Alternator Equipped)

1. See Service Parts Illustration. Cut two sections of hose (3), one approximately 9 in. long and one approximately 14 in. long.

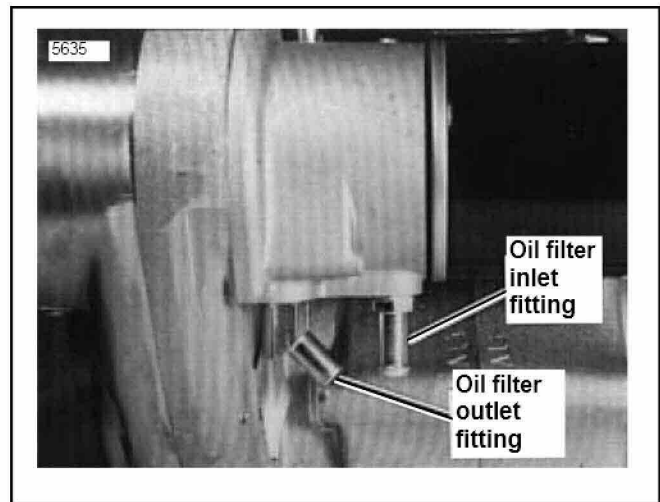

Figure 4. Oil Filter Mount - Late 1984 to 1985 (Alternator Equipped)

2. See Figures 1 and 4. Disconnect the oil return line at the oil pump and oil filter inlet. Use a pan to catch any oil that may spill.
3. See Figures 3 and 4. Connect 9 in. hose to oil filter inlet fitting and outlet fitting on oil cooler. Secure with clamps from kit.
4. See Figures 1 and 3. Connect 14 in. hose to oil pump return fitting. Route hose forward and through hole in right front engine mount and up to oil cooler inlet fitting. Secure connections with small clamps from kit.

#### CAUTION

- Tie wrap oil line(s) to upper, inside of frame tube to prevent oil line(s) from hanging outside, below frame tubes. Do not over-tighten tie wraps. Over-tightening could collapse hose, restrict oil flow and cause engine damage. Clip off tie wrap loose ends.
  - Do not route hose below frame tubes or hose could be damaged by debris.
5. Start and run engine. Check all connections, clamps and hose fittings for oil leaks. Add oil if necessary.

### Removing and Installing Hoses- 1986 to 1990 XLH 883, 1100 and 1200 Models

1. See Figures 5 and 6. Disconnect oil return line at the oil pump. The return line is located at the front, top of the oil pump and is secured with a hose clamp. Use a pan to catch any oil that may spill.
2. Cut a section of hose approximately 14 in. long.
3. See Figures 3 and 6. Connect 14 in. inlet hose to oil cooler inlet fitting. Route hose down and back between front engine mounts and connect to oil pump return fitting. Secure connections with small clamps from kit.
4. Install splicer fitting into end of hose removed from oil pump return in Step 1. Secure hose on fitting with clamp. Install new outlet hose from kit on other end of splicer fitting. Secure hose to fitting with clamp from kit. Route hose forward and up to oil cooler outlet fitting, cut to length and secure with clamp.

### CAUTION

- Tie wrap oil line(s) to upper, inside of frame tube to prevent oil line(s) from hanging outside, below frame tubes. Do not over-tighten tie wraps. Over-tightening could collapse hose, restrict oil flow and cause engine damage. Clip off tie wrap loose ends.
  - Do not route hose below frame tubes or hose could be damaged by debris.
5. Start and run engine. Check all connections, clamps and hose fittings for oil leaks. Add oil if necessary.

### Removing and Installing Hoses- 1991 and Later XLH Models

1. Remove entire exhaust system, including muffler support system, following instructions in appropriate Service Manual.
2. See Figures 7 and 8. Disconnect oil return line at the oil pump. The return line is located on the angled fitting at the front of the oil pump and is secured with a hose clamp. Use a pan to catch any oil that may spill.
3. Install 60° elbow hose from kit over the oil pump return fitting. Orient elbow so the free end is aimed toward the front of the vehicle. Secure the elbow to the oil pump return fitting with a hose clamp.
4. Install one of the hose splicer fittings in the other end of the elbow and secure with a clamp.

5. Cut a length of hose that will reach from the hose splicer fitting on the elbow to the inlet fitting on oil cooler.
6. Connect one end of the hose to the hose splicer fitting. Connect other end of hose to oil cooler inlet and secure with clamp(s).

### CAUTION

- Tie wrap oil line(s) to upper, inside of frame tube to prevent oil line(s) from hanging outside, below frame tubes. Do not over-tighten tie wraps. Over-tightening could collapse hose, restrict oil flow and cause engine damage. Clip off tie wrap loose ends.
  - Do not route hose below frame tubes or hose could be damaged by debris.
7. Install the second splicer fitting into end of hose removed from oil pump in Step 3. Secure hose on fitting with clamp. Install new length of hose from kit on other end of splicer fitting. Route hose forward and up to oil cooler outlet fitting, cut to length and secure with clamp.
  8. Be sure hose is properly routed along top of frame tubes and away from exhaust pipes. Secure hose to frame with tie wraps included in kit.
  9. Install exhaust system following instructions in appropriate Service Manual.
  10. Start and run engine. Check all connections, clamps and hose fittings for oil leaks. Add oil if necessary.

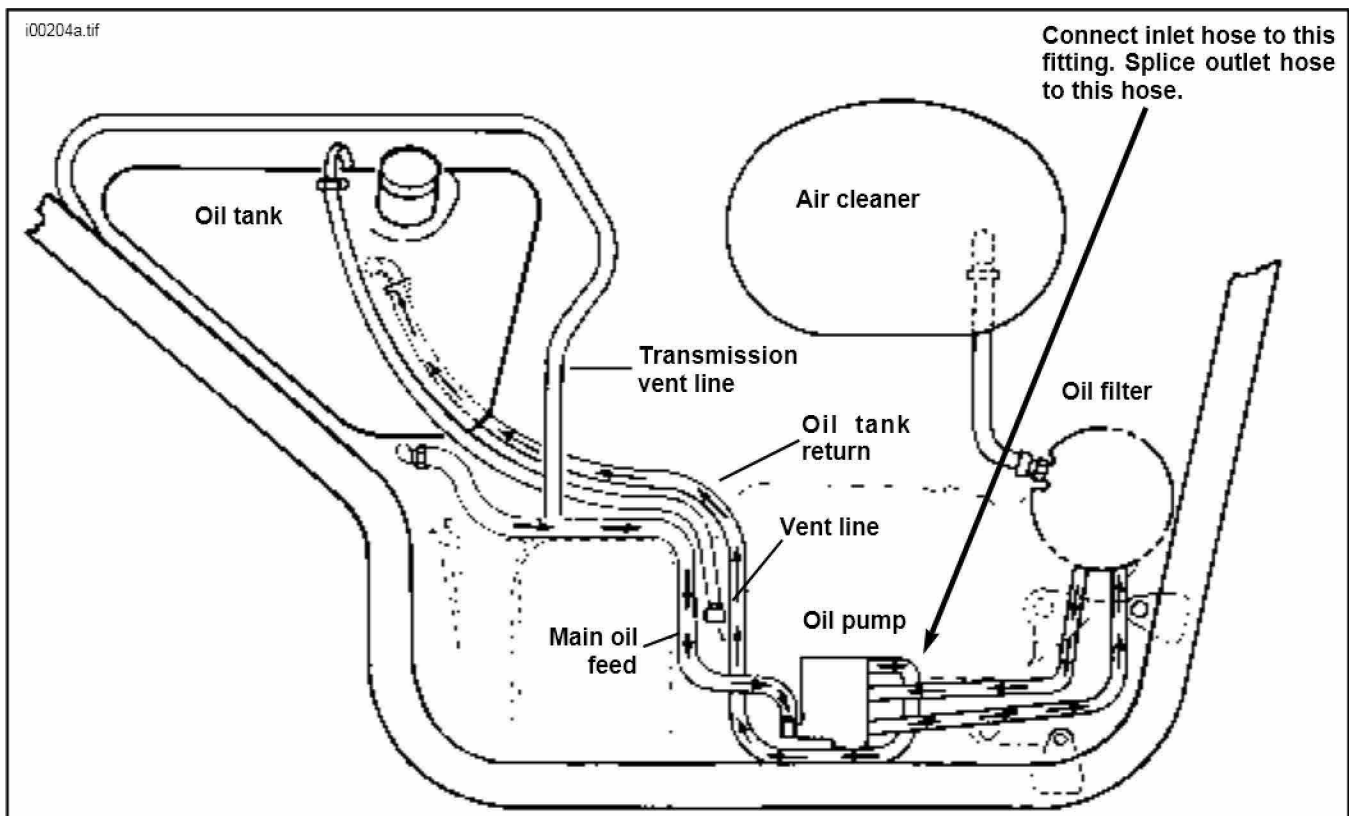

Figure 5. Oil Hose Routing - 1986-1990 XLH 883, 1100 and 1200 Models

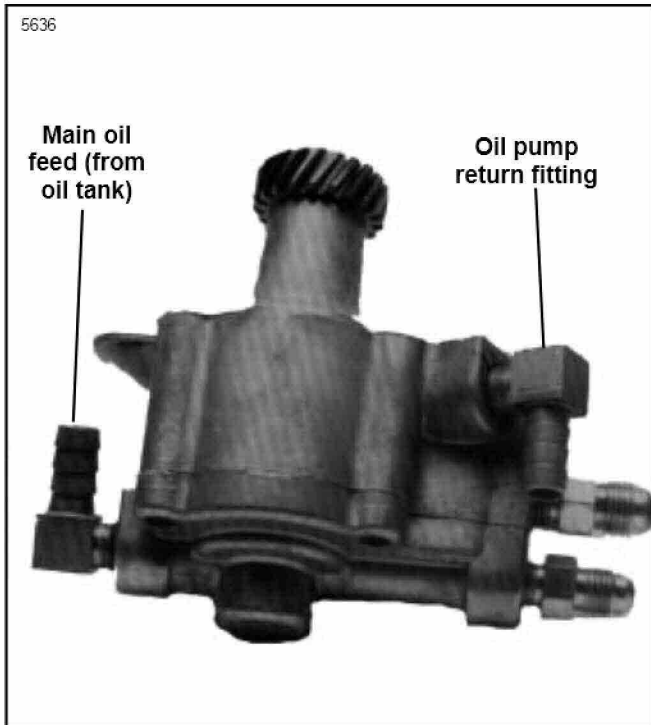

Figure 6. Oil Pump - 1986 to 1990 XLH Models

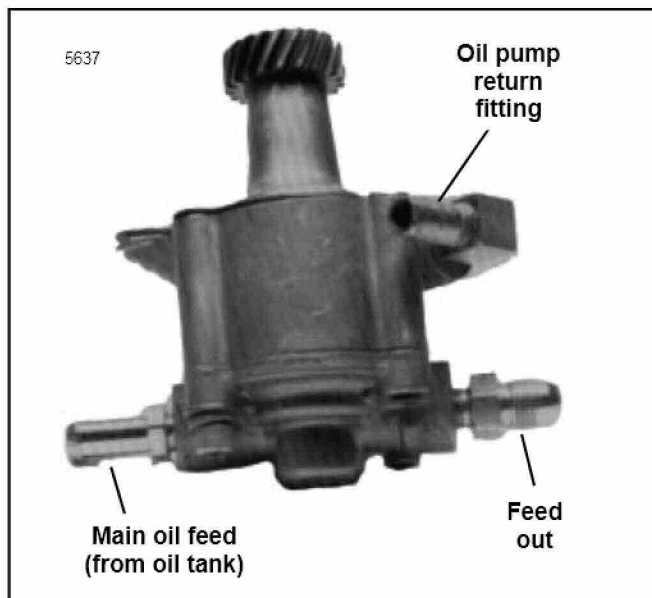

Figure 7. Oil Pump - 1991 and Later XLH Models

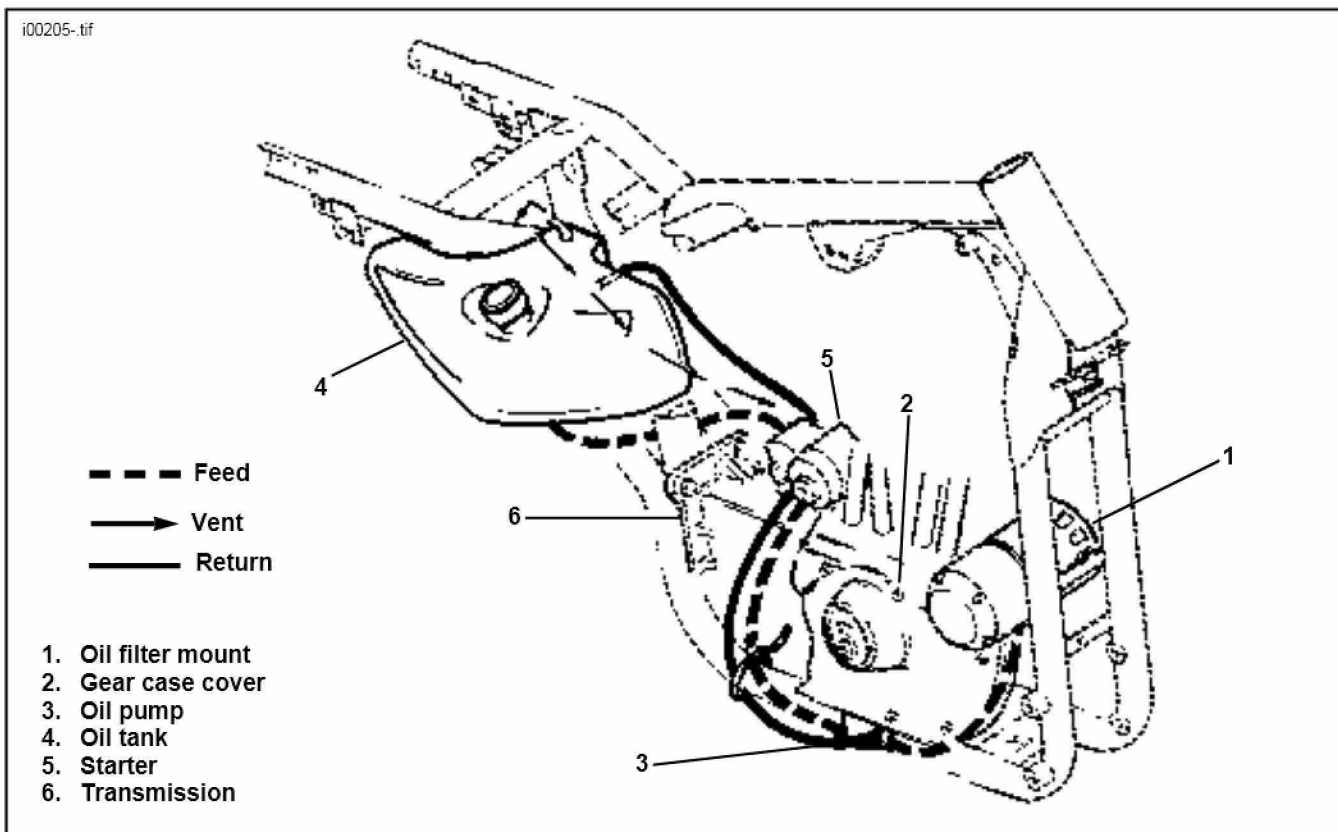

Figure 8. Oil Hose Routing - All 1991 and Later XLH Models



# Service Parts

Part No. 62874-99

Date 3/99

XL Oil Cooler Kit

i0203c

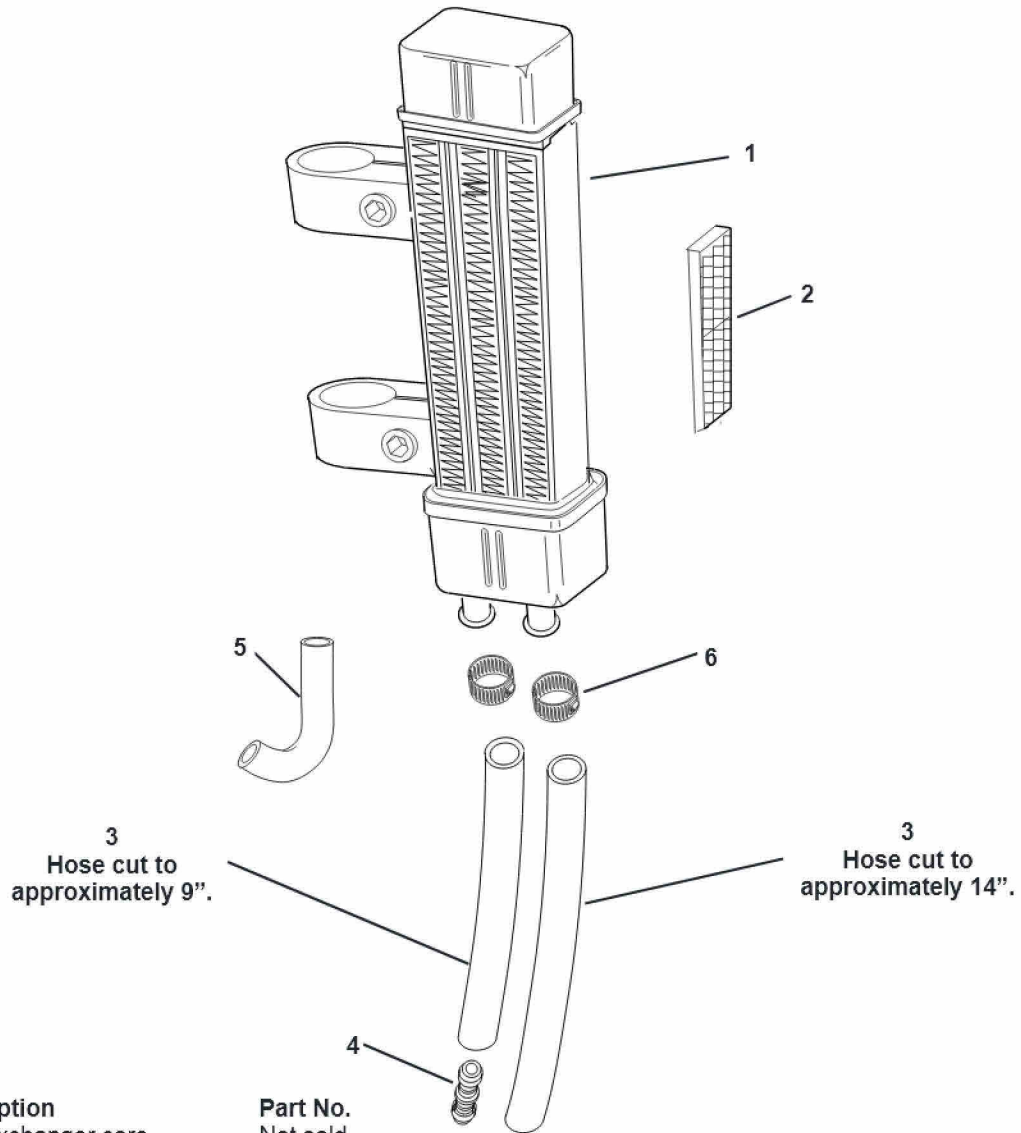

Item	Description	Part No.
1	Heat Exchanger core	Not sold
2	Amber reflector	59253-87
3	Hose, rubber	62518-79
4	Fitting, hose mending (2)	63792-77A
5	Elbow, (used on 1991 and later XLH only)	62436-98
6	Clamp, worm drive (7)	9946
7	Cable straps (3) (not shown)	10006