



# INSTRUCTIONS

-J01323

REV. 1-19-01

Kit Number 25647-01

## XL HIGH PERFORMANCE CAM KIT

### General

This kit is designed for use on 2000 and later XL Evolution Sportsters.

#### CAUTION

This engine related performance part is intended for High Performance or Racing applications and is not legal for sale or use on pollution controlled motor vehicles. This kit may reduce or void the limited vehicle warranty. Engine related performance parts are intended for the experienced rider only.

#### WARNING

A Service Manual is needed to install this kit. The rider's safety depends upon the correct installation of this kit. If the procedure is not within your capabilities or you do not have the correct tools, have your Harley-Davidson dealer perform the installation. Improper installation of this kit could result in death or serious injury.

#### NOTE

A Service Manual for your model vehicle is available from your Harley-Davidson dealer.

Kit contents:

ITEM	DESCRIPTION	PART NUMBER
1	Valve spring collar key (8)	18211-86
2	Collar, valve spring (upper) (4)	18216-98
3	Collar, valve spring (lower) (4)	18217-98
4	Valve Spring unit (4)	18218-98
5	Shim, valve spring .015 (8)	18224-98
6	Shim, valve spring .030 (8)	18225-98
7	Cam, XL 4 speed set	25649-01
8	Seal driver	94450-86

Installation of this kit will require the following gaskets available from your Harley-Davidson dealer:

DESCRIPTION	PART NUMBER
Gasket kit, top overhaul	17032-91
Camgear cover gasket	25263-90C

### Installation

1. Refer to the applicable Service Manual and follow the procedure under Stripping the Motorcycle for Engine Repair.
2. Remove cylinder heads.
3. Compress valve springs and remove upper collar keys, upper collar, and lower collar on all four valves.

#### NOTE

Do not remove valves. If valves are removed, new seals must be installed.

#### CAUTION

Because of the large diameter of the springs in this kit, there may be slight interference between the spring and the rocker box. If interference is detected, it will be necessary to remove a small amount of material from the rocker box.

### XL 883 AND 1200cc ENGINE

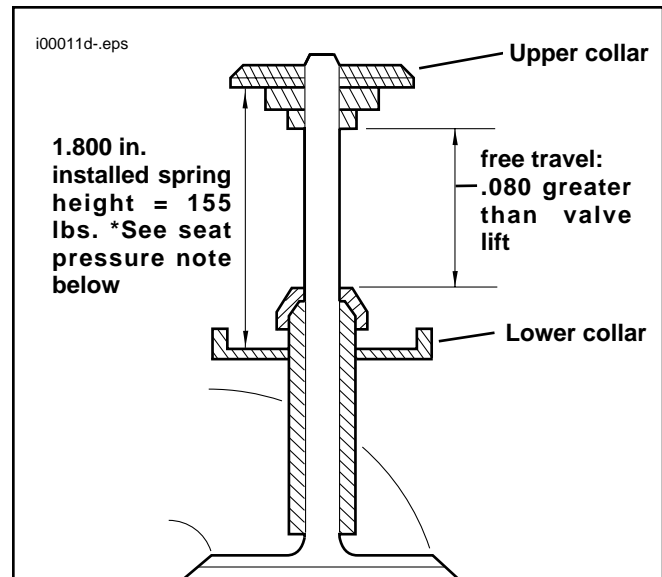

Figure 1. Valve Free Travel Check and Installed Valve Spring Height

- See Figure 1. Install lower valve spring collars, upper collars, and collar keys. Check installed spring height. Add shims (see note below) or remove material from spring seat to reach installed spring height. Remove upper collar keys and upper collars.

**NOTE**

*Shim to desired seat pressure by placing shims under lower collar, but do not use more than .075 in. of shims.*

- Assemble cylinder heads following Service Manual procedures, using springs, collars and keys from this kit.
- Follow the applicable Service Manual procedures to install heads and remaining components disassembled in Step 1.

**\*SEAT PRESSURE NOTE**

*Every .015 in. reduction in spring height = 8 lbs. more of seat pressure. For example:*

*1.785 in. installed spring height = 160 lbs. seat pressure  
1.770 in. installed spring height = 168 lbs. seat pressure*

## Camshaft Installation

Camshaft installation requires the removal of the gear case cover. The cams in this kit may be used with the stock hydraulic tappets.

Follow applicable Service Manual procedures to perform the following:

- Remove ignition components from gear cover and the two bolts that retain the oil filter housing.
- Remove the gear cover screws and gear cover.

**NOTE**

*It is not necessary to remove pinion gear, oil pump gear or oil pump.*

- See Figure 2. Rotate engine to align timing marks. Cams are numbered 1 to 4 from the rear exhaust (1) to the front exhaust (4). Remove camshaft 2. One at a time remove camshaft 1, 3, and 4, and replace with the appropriate camshaft from this kit. Be careful to maintain timing mark alignment. Install camshaft 2 from this kit last. Carefully check alignment of all timing marks.
- Following Service Manual procedures, assemble gear case cover and check that minimum camshaft end play is present. After final assembly, torque cover screws to 80-110 **in-lbs** (9-13 Nm).
- Install ignition components.
- Place modeling clay on the piston valve reliefs. Clay must be about 1/8 in. thick.
- Following Service Manual procedures, install cylinder heads using old head gaskets. Tighten cylinder head screws to 7 ft-lbs following the pattern described in the Service Manual.
- Install push rods.

**CAUTION**

**Wait ten minutes before turning engine after installing push rods. This wait allows tappets to bleed down and prevents bending push rods or valves.**

- Rotate engine so that both valves of the front cylinder are partially open. Shine a light through the exhaust port and look through the spark plug hole. Turn engine, if required, to the point where the exhaust and intake valve heads cross.

There should be 0.040 in. clearance between the two valve heads. See Figure 3. A wire gauge may be used to make this measurement. If insufficient clearance exists, the edges of both the intake and exhaust valves may be ground at a 45° angle as shown in Figure 3.

- Repeat Step 9 for the rear cylinder.
- Carefully turn the engine through two full revolutions by hand. (This will open the valves and compress the clay in the valve reliefs on the pistons. Clay thickness will be measured when heads are removed later.)

**NOTE**

*Exhaust and intake valves from 1200cc engine should have been beveled prior to assembling them into head.*

*Do not reduce the valve margin to less than 0.031 in. On 1200cc engines grind the valve seats deeper into the head to obtain the 0.040 in. clearance between valve heads.*

**NOTE**

*Do not remove heads to bevel valves on 883cc engines or grind valve seats deeper on 1200cc engines at this time — continue with the remaining checks.*

- Rotate engine so that both valves of the front cylinder are fully closed. Check for clearance between the top of the upper spring collar and the bottom of the rocker arm. If less than 0.010 in., mark the offending area of the rocker arm. Remove the rocker arm and carefully grind or file to establish the correct clearance. The area must be polished to remove all tool marks after grinding or filing.

**CAUTION**

**Failure to polish the rocker arm could result in a fatigue failure of the rocker arm.**

- Repeat Step 12 for the rear cylinder.
- Remove the heads and perform the following:
  - Measure the clay thickness in the valve reliefs on the pistons at its thinnest point. This measurement must be at least 0.080 in. If 0.080 in. clearance is not present, the valve reliefs must be machined deeper to obtain the 0.080 in. clearance.

**CAUTION**

**Do not deepen valve reliefs more than 0.020 in. or piston will be ruined.**

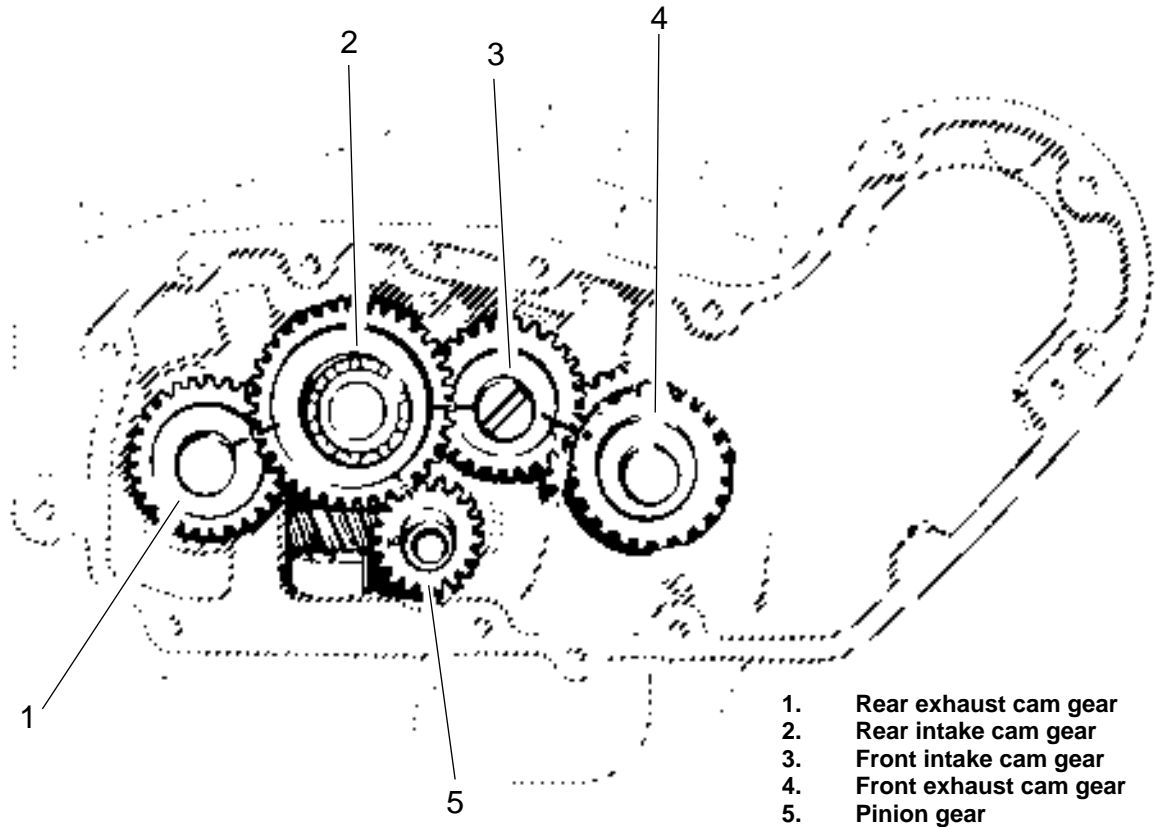

Figure 2. Proper Alignment of Camshaft Timing Marks

- B. If 0.040 in. clearance was not present when checked in Step 10, remove and bevel the intake and exhaust valves on 883cc engines. If 0.040 in. clearance is not present on 1200cc engines, the valve seats must be ground deeper to obtain the clearance. After grinding valve seats, assemble the engine and recheck the valve head clearance per Step 10.

**NOTE**

*If valve seats are ground, recheck valve stem protrusion and distance between valve spring collars. Free travel will be increased and need not be rechecked. Install new valve guide seals if valves were removed.*

15. Following applicable Service Manual procedures, assemble the engine using new gaskets.
16. Check ignition timing by following applicable Service Manual procedures.

**Obtaining Optimum Engine Output**

To obtain maximum engine output available with installation of this Screamin' Eagle Cam Kit, Harley-Davidson recommends carburetor, air cleaner, exhaust system and ignition module changes. See your Harley-Davidson dealer for details.

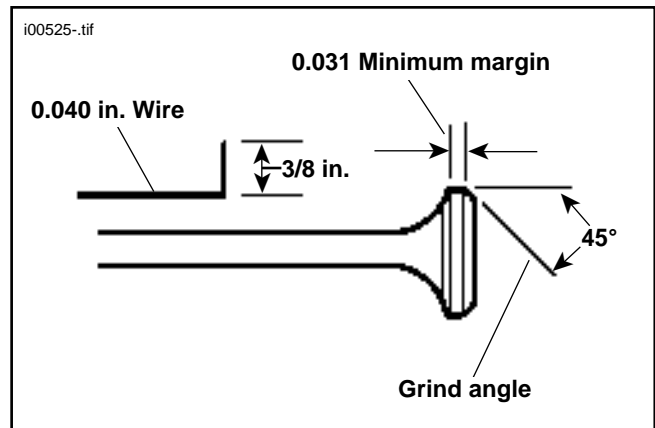

Figure 3. Beveling Valve Heads



# Service Parts

Part No. 25647-01

Date 1/01

## XL High Performance Cam Kit

i01420-.eps

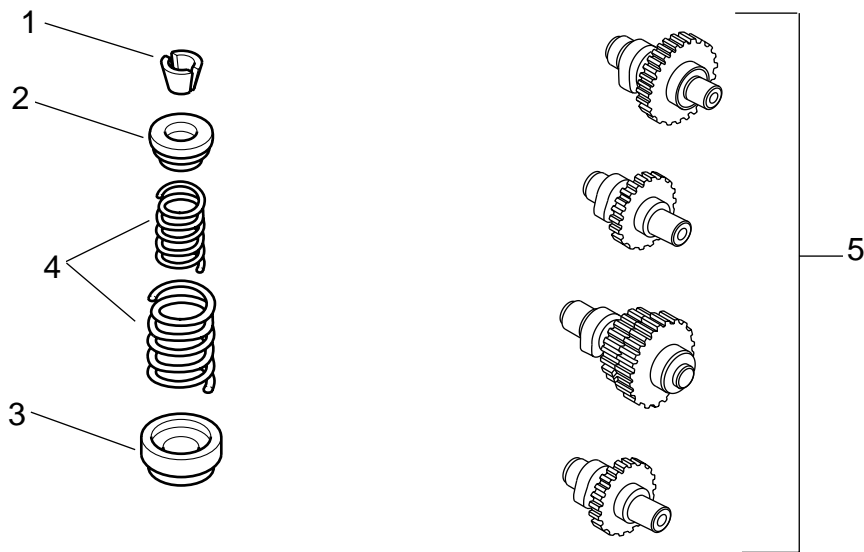

Item	Description	Part No.	Item	Description	Part No.
1	Valve spring collar key (8)	18211-86	6	Shim, valve spring .015 in. (8)	(not shown)
2	Collar, valve spring, upper (4)	18216-98	7	Shim, valve spring .030 in. (8)	18224-98
3	Collar, valve spring, lower (4)	18217-98		(not shown)	18225-98
4	Valve spring unit (4)	18218-98	8	Seal driver (not shown)	94450-86
5	XL cam set	25649-01			