



INSTRUCTIONS

-J01186

REV. 2-23-01

Kit Number 17378-98

SCREAMIN' EAGLE ROLLER ROCKER ARM KIT

General

These roller rocker arms are designed to fit 1984 and later 1340 Evolution Big Twins, 1986 and later 883 and 1200 Evolution XL and 1999 and later Twin Cam 88 Engines.

Kit contents:

Description	Part No.
Roller rocker arms (2) (front-intake, rear-exhaust)	17376-98
Roller rocker arms (2) (rear-intake, front-exhaust)	17377-98

Installation

NOTE

A Service Manual for your motorcycle is available from your Harley-Davidson Dealer.

CAUTION

A Service Manual is needed to install this kit. The rider's safety depends upon the correct installation of this kit. If the procedure is not within your capabilities or you do not have the correct tools, have your Harley-Davidson dealer perform the installation. Improper installation of this kit could result in death or serious injury.

1. Remove existing rocker arms per applicable Service Manual instructions.
2. Install new roller rocker arms per applicable Service Manual. The new rocker arms install the same as original equipment rocker arms.

NOTE

To avoid possible interference between the pushrods and upper pushrod covers, shifting the rocker arm supports toward the engine's cam side may be required. To check the clearance between the pushrods and covers, rotate the engine so that the cylinder you are checking has both valves in the closed position.

NOTE

See Figure 1. On Twin Cam 88 Engines clearance between the top rocker covers and the roller rocker arms must be a minimum of .060 inches. It may be necessary to remove some of the rib material inside the rocker covers to achieve the required clearance.

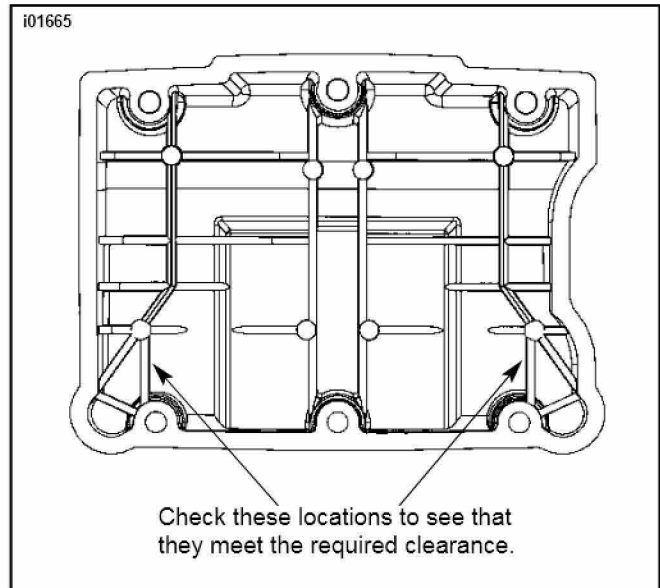

Figure 1. Twin Cam 88 Engine Clearance