



INSTRUCTIONS

-J00974

2013-11-01

SPORTSTER VOLTAGE REGULATOR COVER

GENERAL

Kit Number

74579-97

Models

For model fitment information, see the P&A retail catalog or the Parts and Accessories section of www.harley-davidson.com (English only).

NOTE

This voltage regulator cover cannot be used along with Front Spoiler, Part Number 58597-97, unless motorcycle is also equipped with a Sport or Cafe Front Fender, and a Sportster Regulator Cover Relocation Kit, Part Number 74568-98.

NOTE

To provide clearance on models with front mounted horns (STD/HUG/1200S), it may be necessary to relocate the horn 1/2 inch higher. See Horn Relocation below.

INSTALLATION

1. Remove regulator mounting screws and discard screws.
2. See Figure 1. Install regulator in original location with cover using hardware shown. Tighten mounting screws to 10-12 ft-lbs (13-16 Nm).

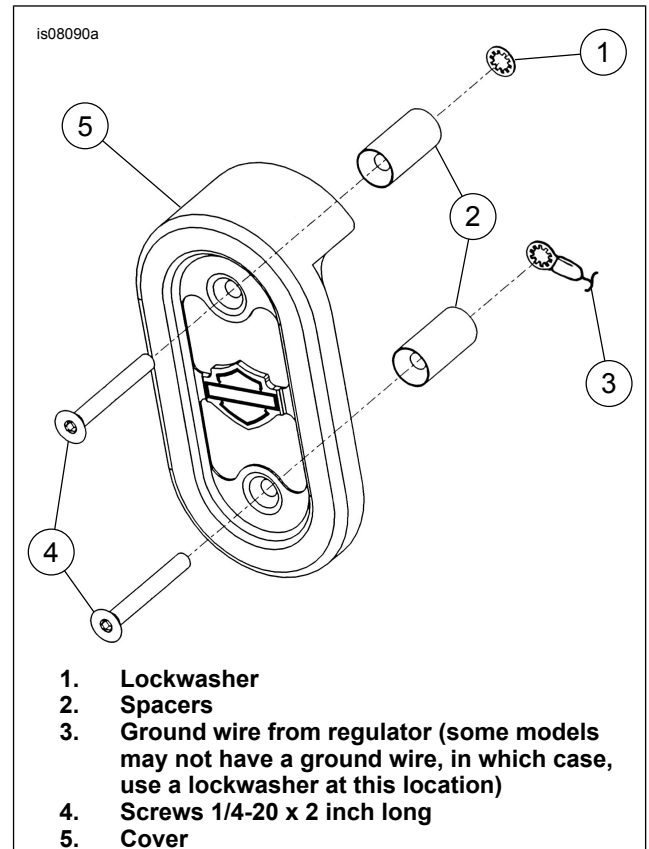

Figure 1. Regulator Cover Components

Horn Relocation

1. Remove electrical connectors from horn.
2. Remove nut that holds horn to mounting bracket and remove horn.
3. Remove screws that hold mounting bracket in place and remove bracket.
4. Drill a 1/4 inch diameter hole 1/2 in. (12.7mm) above existing mounting hole.
5. Install mounting bracket and horn with horn located in the new higher position.



is08091

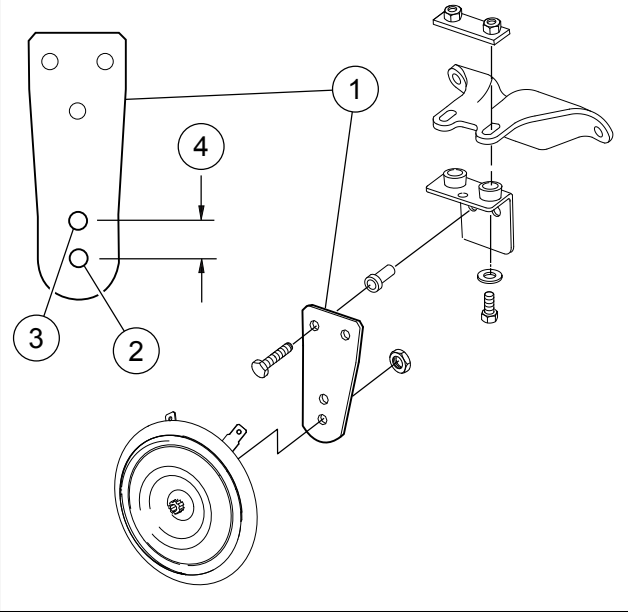

Figure 2. Relocating Horn 1/2 Inch Higher