



INSTRUCTIONS

-J00938

REV. 5-20-02

Kit Numbers 32054-98, 32055-98, 32056-98, and 32072-98

SCREAMIN' EAGLE SPARK PLUG WIRE KIT

General

These spark plug wires are designed for installation on 1998 and later XL1200S models.

- 32054-98Black
- 32055-98Red
- 32056-98Orange
- 32072-98Yellow

Installation

⚠WARNING

To avoid accidental start-up of motorcycle, and possible personal injury, disconnect the battery cables (negative cable first) before performing any of the following procedures. If the positive cable should contact ground with the negative cable installed, the resulting sparks may cause a battery explosion resulting in death or serious injury.

⚠WARNING

Gasoline is extremely flammable and highly explosive under certain conditions. Do not smoke or allow open flame or sparks anywhere in the area when draining or servicing the fuel system. Drain gasoline into approved gasoline container only. Failure to follow instructions could result in death or serious injury.

NOTE

A Service Manual for your motorcycle is available from your Harley-Davidson dealer.

1. Remove fuel tank following instructions in appropriate Service Manual. Place tank in a safe location where it will not be damaged or scratched. Set all fuel tank hardware aside for later reinstallation.

IMPORTANT NOTE

When installing spark plug wires, remove only **one wire at a time** and install the wire to replace it before moving on to the next wire.

2. Follow Spark Plug Wire Length Chart and Wire Routing Illustration shown below to install spark plug wires. Make sure boots are seated firmly on plugs and into the coil towers. Place wires back into original clips as shown.
3. Re-assemble fuel tank to frame following Service Manual procedures.

Spark Plug Wire Length Chart

Plug Wire #	Approx. Length	Plug Boot Style
1	16 1/2"	Short
2	15 1/2"	Long
3	20"	Short
4	15 3/4"	Long

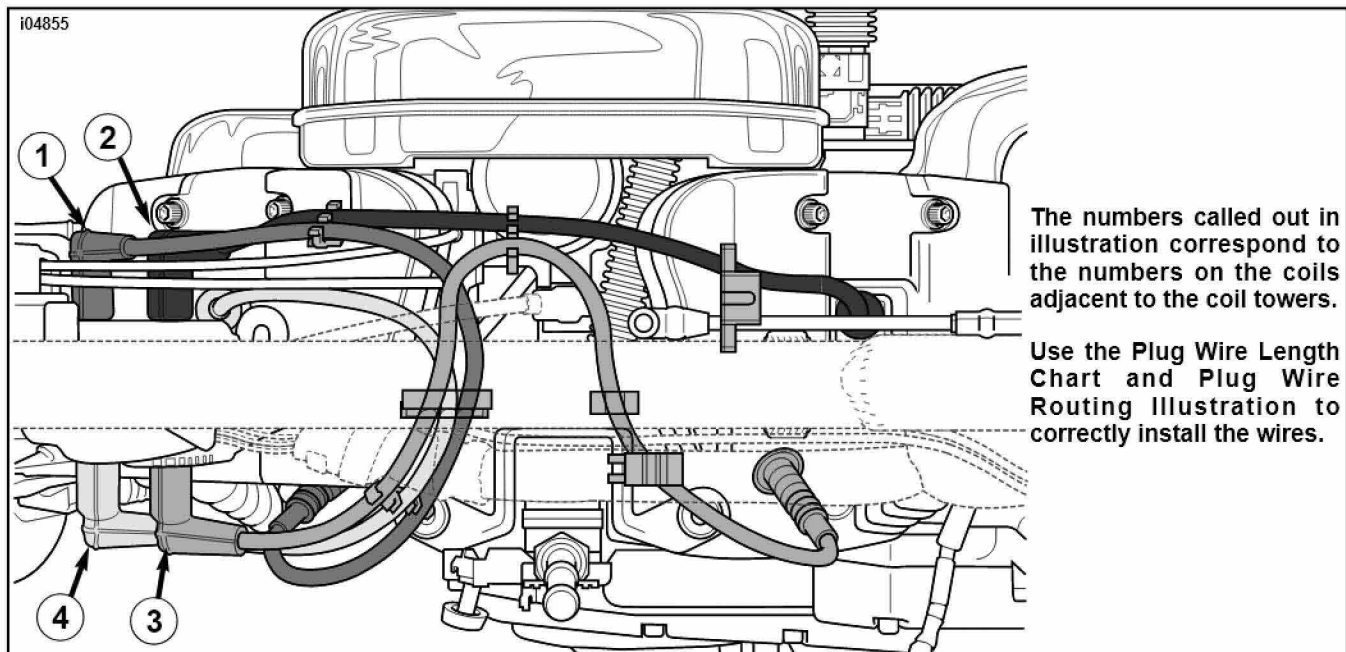

The numbers called out in illustration correspond to the numbers on the coils adjacent to the coil towers.

Use the Plug Wire Length Chart and Plug Wire Routing Illustration to correctly install the wires.

Spark Plug Wire Routing