



INSTRUCTIONS

-J00913

REV. 6-13-97

Kit Number 61212-94B

1986 -1991 XLH (Sportster) FUEL TANK HARDWARE KIT

This kit contains the hardware and components required to install a 3.3 gallon fuel tank kit, Part No. 61618-96C, on all 1986 - 1991 XLH models.

See Service Parts page for kit contents:

Removal – Stock Fuel Tank

⚠WARNING

To avoid accidental start-up of motorcycle, and possible personal injury, disconnect the battery cables (negative cable first) before performing any of the following procedures. If the positive cable should contact ground with the negative cable installed, the resulting sparks may cause a battery explosion resulting in personal injury.

⚠WARNING

To avoid personal injury, do not smoke or allow open flame or sparks anywhere in the area when working on fuel system components. Gasoline is extremely flammable and highly explosive under certain conditions.

1. Remove stock fuel tank following instructions given in the applicable Service Manual. Note the position of all parts so they can be reassembled correctly when new tank is mounted.
2. See Figure 1. Disconnect vent hose at fitting under fuel tank.

NOTE

See Service Parts illustration. Discard existing bolts (5 and 6), nuts (14) and large flat washers (13) on rear mount bolt. Also discard fuel tank cap. Retain throttle cable clip on right end of front mount bolt. Use bolts, washers, nuts and fuel tank cap supplied in hardware kit on new tank.

3. Remove air cleaner, backplate and hose clamp on fuel hose at carburetor. Remove and discard stock fuel hose.

Installation-Fuel Tank Mounting Hardware

NOTE

The fuel tank being installed has the fuel valve fitting on the left side of the tank and the tank is vented with a vapor valve.

1. Install grommets in mounting holes of new tank following instructions given in Instruction Sheet for 61618-96C.
2. See Service Parts illustration. Install two T-spacer (7) in grommets with flanges inboard in rear mounting tabs. In the front mounting tabs, the T-spacers must be installed with flanges outboard.
3. See Service Parts illustration. Install fuel shutoff valve (11) supplied in hardware kit using old mounting nut. The valve hose fitting should face the rear and be parallel with tunnel in tank. See Instruction Sheet for 61918-96C for fuel valve installation instructions. Do not tighten nut fully. Final positioning and tightening will be done with tank mounted.

Additional Modifications

1. See Service Parts illustration. Remove stock coil bracket and install new coil bracket (4) from hardware kit using stock mounting hardware.
2. If motorcycle is equipped with chrome top engine mount cover, Part No. 16274-88T, or similar after-market cover, the cover must be removed.

Install a regular locknut, Part No. 7775, in place of the acorn nut that was used to secure the chrome top engine mount cover.

Installation-Vent Hose (California Models)

NOTE

On California vehicles with EVAP equipment, the existing EVAP system is used.

1. See Figure 5. Attach to tank vent fitting (1) (located at right, rear, bottom of new fuel tank) the large end of 90° connector (6). Attach small end of 90° connector to straight connector (7). Attach new vent hose (8) to straight connector (7).
2. Position the vent hose (8) along the frame backbone. Eliminate any low points.
3. Measure and cut sufficient new vent hose (8) and attach it to straight connector (7) in evap system (not shown).

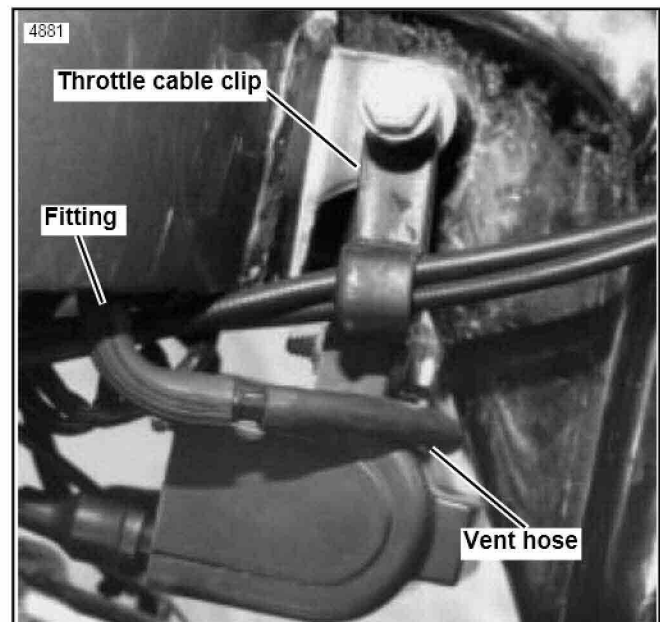

Figure 1. Right Side View

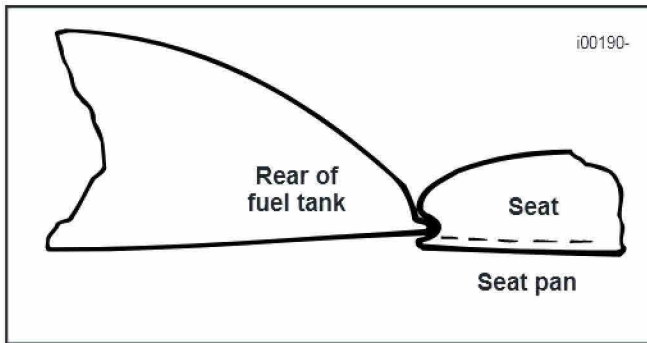

Figure 2. Tank To Seat Location



Figure 3. Fuel Valve And Hose location

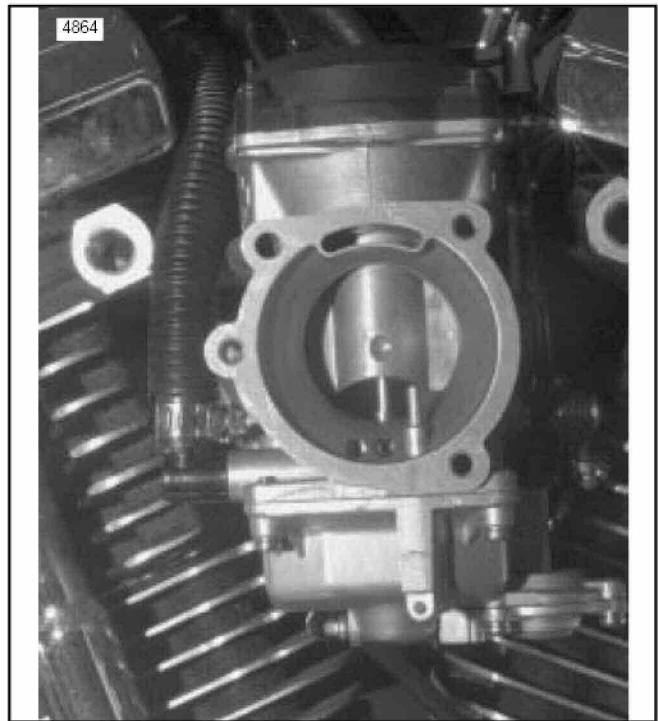

Figure 4. Hose Routing At Carburetor

Installation-Vapor Valve / Vent Hose (Non-California Models)

CAUTION

To be operative, the vapor valve must be installed vertically with the long fitting upward.

1. See Figure 5. Attach vapor valve (2) to left downtube (5) with cable strap (3). Locate vapor valve (2) approximately 4 in. below upper front engine mount on inside rear quadrant of downtube (5).
2. Use the following new components from Gas Tank Kit, Part No. 61618-96C, to reconnect vent line:
 - 90° elbow (27250-96A)
 - straight fitting (27249-96)

Attach to tank vent fitting (1) (located at right, middle, bottom of new fuel tank) the small end of 90° connector (6). Attach large end of 90° connector to the new straight connector (7). Attach new vent hose (8) to straight connector (7).

3. Route vent hose (8) over top of coil (4) and behind downtube (5) to top of vapor valve (2). Cut vent hose (8) to length and attach loose end to top of vapor valve (2).
4. Connect remaining piece of vent hose (8) to bottom of vapor valve (2) and extend hose down left downtube (5) on inside rear quadrant to bottom of frame. Trim hose so it does not contact the ground or moving parts of the motorcycle.

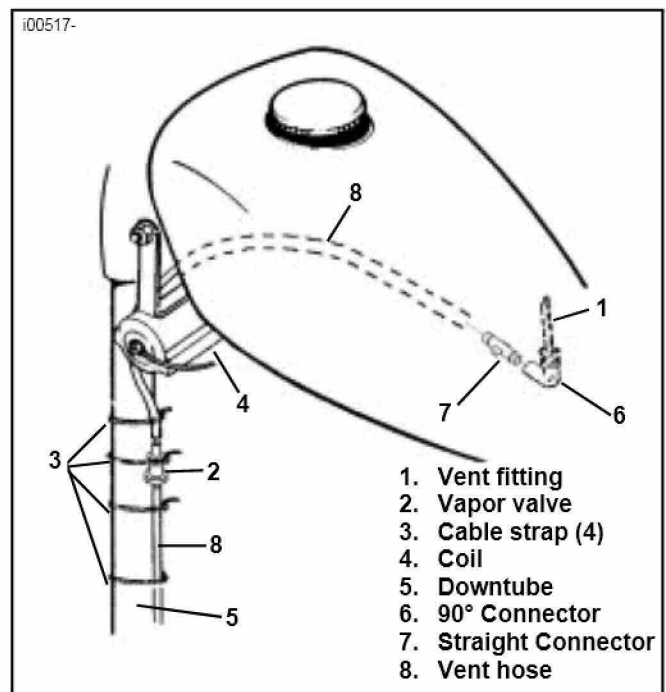

Figure 5. Vent Hose Routing (Left Side)

CAUTION

Do not tighten cable straps excessively where they pinch or compress hose. Pinching the hose could block venting and result in erratic engine operation.

5. Attach vent hose (8) to downtube (5) with remaining cable straps (3) spaced in equal increments.

Installation - New Fuel Tank

1. Place fuel tank on frame. Check the position of the main wiring harness, other wires, and vent hose attached to the frame backbone. If fuel tank will pinch wiring, move the harness and wires down under the frame backbone.

NOTE

If required, cut the existing cable straps, relocate the wiring and secure it with the cable straps included with kit.

2. Place fuel tank on frame.
3. See Figure 2. If tank contacts seat, lift rear of fuel tank so bottom rear edge of tank is above seat pan. Keep tank in this position and install the rear mounting bolt and washer.
4. See Service Parts illustration. Select the correct length front bolt (5). On 883 cc models use the 5/16-18 x 4-3/8 in. bolt. 1200 cc models use the 5/16-18 x 3-5/8 in. bolt.
5. Install the front bolt, making certain coil bracket is positioned inboard of grommets and throttle cable clip is positioned as shown in Figure 1.
6. On 883 cc models, make certain that horn spacer (8) and horn (9) are properly positioned on front mount bolt.
7. Check that no wires or hoses are being pinched by fuel tank. Move wire and/or hoses as needed install nuts (6) and tighten front and rear bolts to 8-16 ft-lbs.
8. See Figure 3. Place hose clamp on end of fuel hose with 90° bend. Route hose in front of rear cylinder head to carburetor.

9. Install fuel hose on fuel valve and position valve so hose and hose clamp are not touching top engine bracket. Tighten hose clamp.
10. Tighten valve nut to 18 ft-lbs.
11. See Figure 4. Slip conduit and hose clamp on fuel line. Check hose length and cut off any excess.
12. To avoid interference with backplate, position fuel hose clamp as shown. Tighten hose clamp.
13. Replace fuel filler cap with new filler cap from kit.
14. Fill tank with gasoline and check fuel valve and fuel line for leaks.
15. Perform "Final Checks".

Final Checks

WARNING

Always connect the positive battery cable first. If the positive cable should contact ground with the negative cable installed, the resulting sparks may cause a battery explosion resulting in personal injury.

1. Reconnect battery cables, positive cable first.
2. Install seat, backplate, and air cleaner.
3. Test horn operation on 883 cc models. If horn does not operate make certain horn is electrically grounded.



Service Parts

Part No. 61212-94B

Date 6/97

1986-1991 XLH Fuel Tank Hardware Kit

sp61212

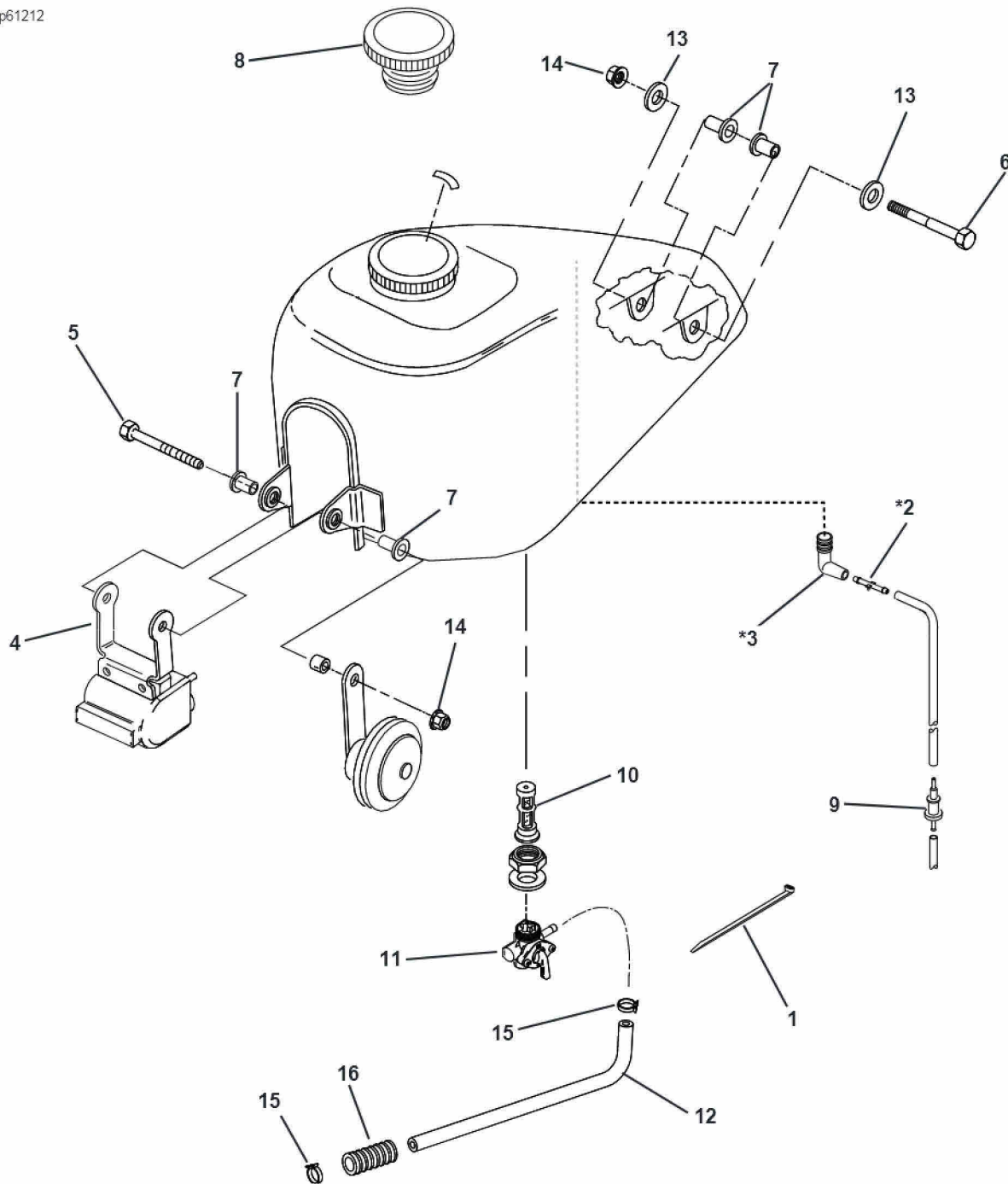

Item	Description	Part No.	Item	Description	Part No.
1	Cable strap	10006	7	T-spacer	5787
2	Connector, straight (included in kit 61618-96C)		8	Filler cap	61272-92A
3	Connector, 90° (included in kit 61618-96C)		9	Vapor valve	62150-85
4	Coil bracket	31723-71B	10	Fuel valve filter	62166-81A
5	Bolt, hex cap, 5/16-18 x 4-1/2 in. (XLH 883 only)	4067	11	Fuel valve body	62167-81
	Bolt, hex cap, 5/16-18 x 3-5/8 in. (XLH 1200 only)	4116	12	Fuel hose	62348-95
6	Bolt, hex cap, 5/16-18 x 3-1/8 in.	4117	13	Washer, 5/16 id	6788
			14	Locknut	7531
			15	Hose clamp	9946
			16	Fuel hose shield	63581-95