



INSTRUCTIONS

-J00414

REV. 9-1-94

Kit Number 67294-95

CHROME DUAL GAUGE KIT

General

This kit is designed for installation on 1995 XLH 1200 and 1995 FXDS-Con model motorcycles equipped with an electronic speedometer and tachometer.

CAUTION

Use the appropriate Service Manual procedure. If the procedure is not within your capabilities or you do not have the correct tools, have your Harley-Davidson dealer perform the installation.

QTY DESCRIPTION

6	Cable straps
1	Bracket, speedometer/tachometer
1	Cover, rear, tachometer
1	Cover, rear, speedometer
2	Butt splice
4	Ring terminals
2	Hose clamp

Installation

CAUTION

To prevent short circuits while installing this kit, disconnect the battery cables (negative cable first) before you begin this procedure.

Removal

DISCONNECT ELECTRONIC SPEEDOMETER AND TACHOMETER

1. Refer to applicable Service Manual procedure and remove seat.
2. Refer to XLH Service Manual procedure and remove fuel tank. On FXD models, remove fuel tank mounting bolts and lift tank.
3. See Figures 1 and 2. The 3-place speedometer sensor connector [65] is located on the frame beneath the seat. Remove connector from t-stud and disconnect. Detach sensor harness from left frame tube.
4. Detach headlamp assembly from top fork bracket, to allow removal of speedometer sensor harness.
5. Unscrew speedometer reset switch boot. Remove cover screws and covers from backs of gauges.

NOTE

Some early electronic speedometers and tachometers were wired directly into the gauge.

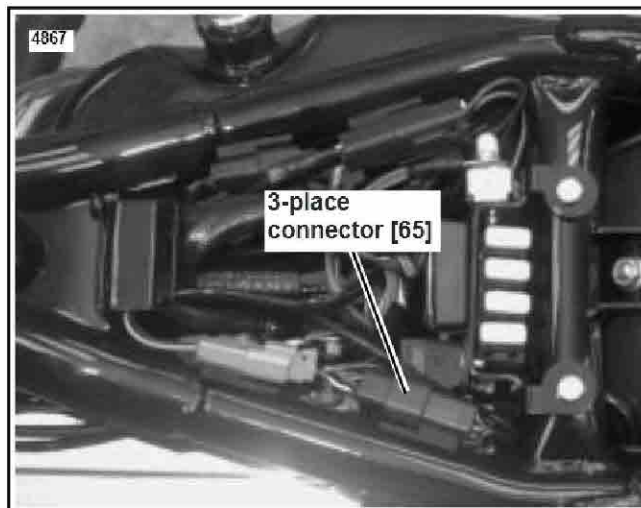

Figure 1. Speedometer Sensor Connection [65] - XLH

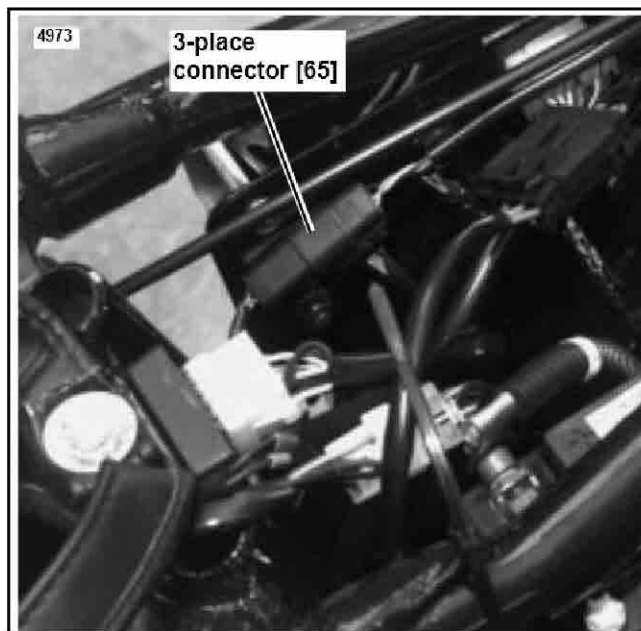

Figure 2. Speedometer Sensor Connection [65] - Dyna

"Hard-wired" Gauges - Tachometer

On this type of tachometer, the pink, black and orange/white wires go into the gauge.

6. See Figure 3. Cut the pink wire approximately 1 in. from the hole.
7. Cut the black and orange/white harness-side wires at the ring terminals. Do not cut the gauge-side wires.

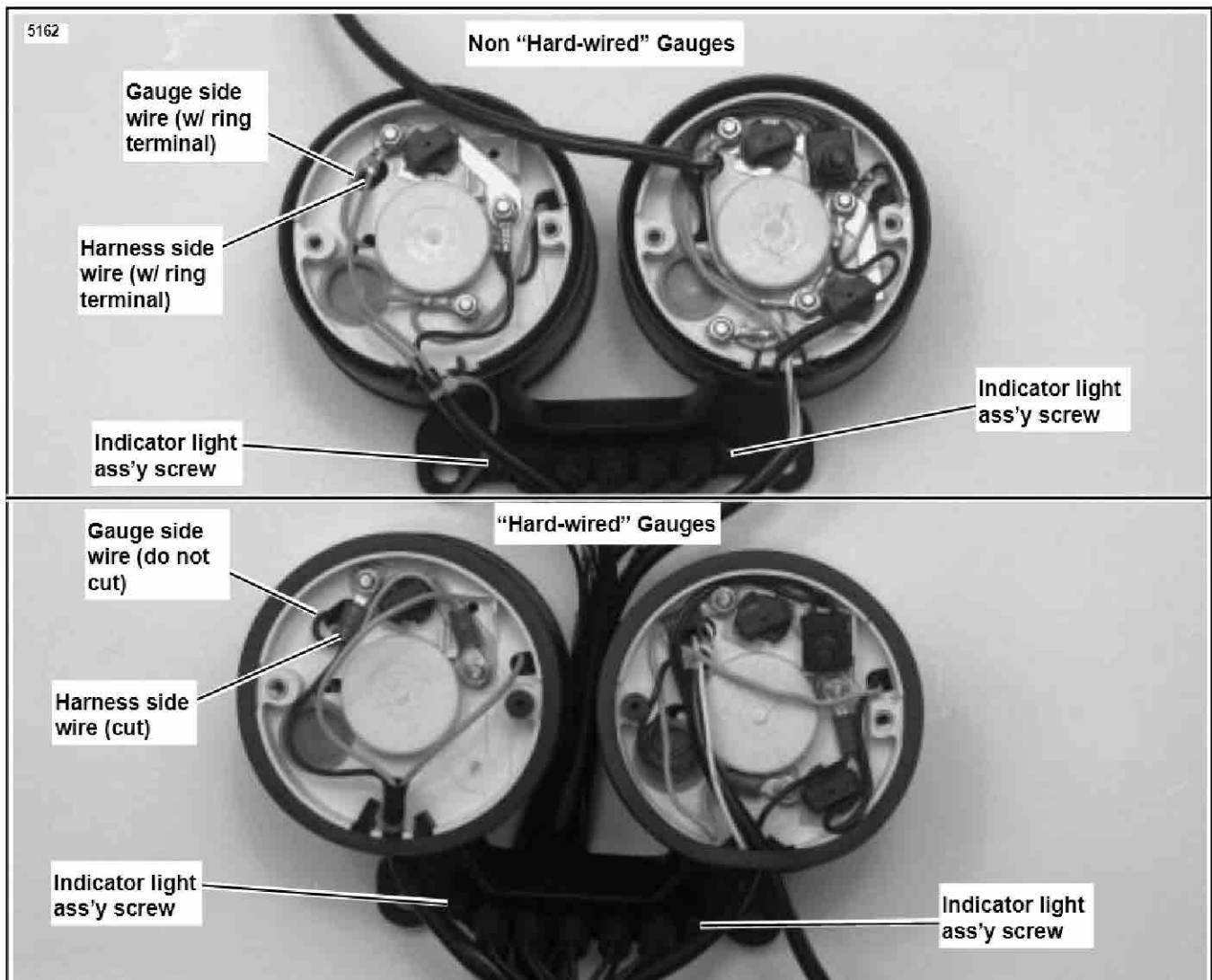

Figure 3. Dual Gauge Comparison

"Hard-wired" Gauges - Speedometer

The speedometer black, orange/white and white/green wires are wired directly into the gauge.

8. Cut the white/green wire approximately 1 in. from the hole.
9. Cut the black and orange/white harness-side wires at the ring terminals. Do not cut the gauge-side wires.

Non "Hard-wired" Gauges

The later gauges use ring terminals for all connections.

10. On both of this type of gauge, remove ring terminals' nuts and washers. Remove the ring terminals on the harness side. After removing ONLY the harness side ring terminals, install the nuts and washers on the gauge studs finger tight.

REMOVE GAUGE FROM BRACKET

1. See Figure 4. Remove rear gauge gasket. Push on rear of gauge while simultaneously pulling gauge and front gasket from bracket.

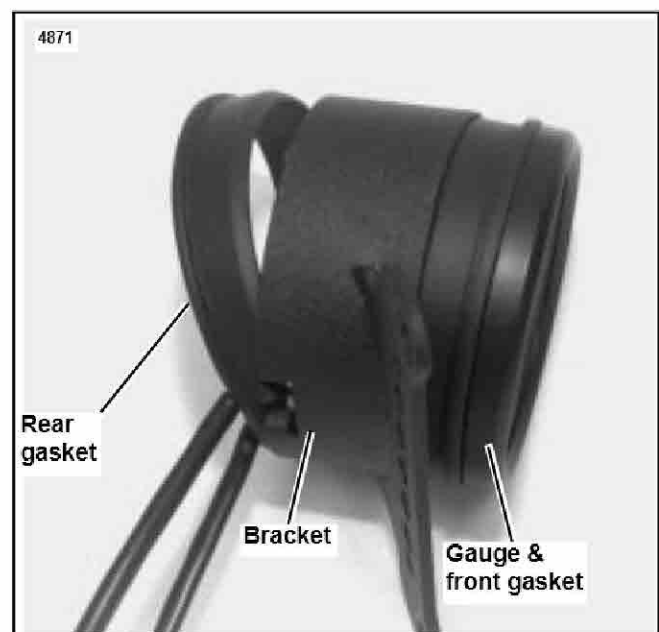

Figure 4. Speedometer/Tachometer Front and Rear Gaskets (Single Gauge Bracket Shown For Illustration Purposes)

- Remove gauge from front of old bracket. Retain gaskets.

REMOVE INDICATOR LIGHTS FROM BRACKET

- See Figure 5. Remove the screws that secure the gauge bracket to the handlebar clamp.

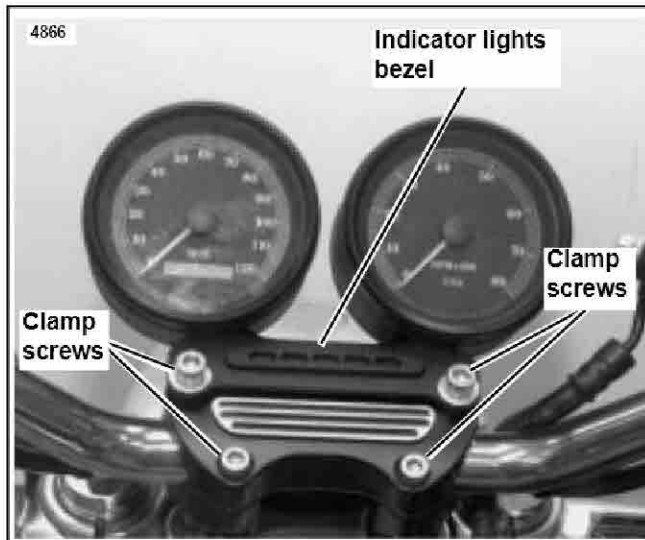

Figure 5. Handlebar Clamp Screws

- See Figure 3. Remove the screws that secure the indicator light components to the bracket. Retain screws and indicator light components for installation on new speedometer/tachometer bracket.

INSTALL INDICATOR LIGHTS ON BRACKET

- See Figure 5. Place the indicator light bezel and color strip on front of gauge bracket. Be sure color strip is positioned on locating pins.
- See Figure 3. Install indicator light socket assembly on rear of dual bracket. Be sure locating pins on bezel enter holes in socket assembly. Install mounting screws.

INSTALL SPEEDOMETER/TACHOMETER BRACKET

See Figure 5. Place speedometer/tachometer bracket in position and install screws snugly enough to hold handlebars in place. Do not tighten at this time.

INSTALL GAUGE IN KIT BRACKET

- Lubricate the front and rear gaskets with isopropyl alcohol or glass cleaner to ease installation.
- Insert gauge into the front of the correct bracket opening. Be sure wire guides are aligned with opening at bottom of bracket.
- See Figure 6. Place rear gasket in position and align gasket tabs. Work gasket into space between gauge and bracket by pushing gauge against one side of bracket while pushing gasket into position at the opposite side.

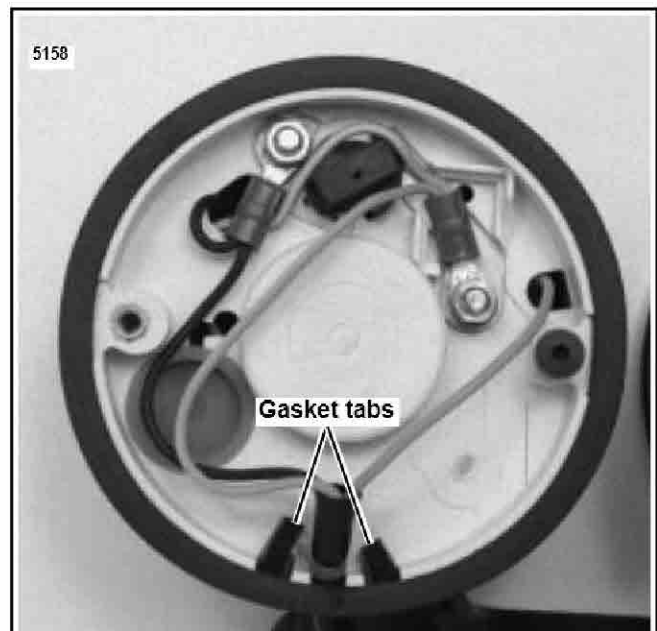

Figure 6. Rear Cover Removed from Tachometer

- See Figure 3. Position wire harnesses under gasket, to gauge. Be sure correct harness is going to proper gauge.
- See Figures 1 or 2. Route speedometer sensor cable into position under fuel tank and seat. Connect 3-place connector [65] under the seat.

FXD

Place sensor cable into the clips beneath the fuel tank and replace the cable ties that hold the harness to the frame tube.

XLH

Replace the cable ties that hold the harness to the frame tube.

- Refer to applicable Service Manual procedures and install or position fuel tank. Use hose clamp(s) in kit. Tighten fuel tank mounting bolts to 12 ft-lbs.

⚠WARNING

After installing seat, pull upward on front of seat to be sure it is locked in position. If seat is loose, it could shift position during vehicle operation and startle the rider, causing loss of control and personal injury.

- Install seat.
- Install headlamp. Tighten bolts to 12-18 ft-lbs.

CONNECT SPEEDOMETER/TACHOMETER LEADS

After installing gauges in bracket, connect leads as follows:

“Hard-wired” Gauges

- Strip 3/16 in. insulation off the ends of the wires you previously cut. Crimp a ring terminal from the kit onto the black harness-side wires using HD-38125-8 crimper.
- Crimp a ring terminal from the kit onto the orange/white

harness-side wires using HD-38125-8 crimper.

3. Use a butt connector from the kit and crimp the pink wire together. See SEALED BUTT CONNECTORS on page 5 of this Instruction Sheet.
4. Use a butt connector from the kit and crimp the white/green wire together. See SEALED BUTT CONNECTORS at end of this Instruction Sheet.
5. Remove nuts and washers. Stack the ring terminals on the correct studs. Install the nuts and washers on the gauge studs and tighten to 8 in-lbs.
6. Check that speedometer reset switch is in correct position and that all wires are positioned so they will not be pinched by rear cover.
7. Place rear cover on speedometer. Install cover screws and reset switch boot.
8. Check that all tachometer wires are positioned so they will not be pinched by rear cover.
9. Place rear cover on tachometer. Install cover screws

Non "Hard-wired" Gauges

1. On both of this type of gauge, remove nuts and washers and place the ring terminals on the correct studs.
2. Install the nuts and washers on the gauge studs and tighten.
3. Place rear cover on speedometer. Install cover screws and reset switch boot.
4. Place rear cover on tachometer. Install cover screws

FINAL CHECKS AND ADJUSTMENTS

1. See Figure 7. Adjust handlebars to Rider's normal riding position; hold in position.
 - a. Tighten two rear screws (3) until cast-in spacers (2) of upper clamp contact handlebar lower clamps (1).
 - b. Tighten front screws (4) to 12 - 15 ft-lbs (16 - 20 Nm).
 - c. Final tighten rear screws to 12 - 15 ft-lbs (16 - 20 Nm). There should be a slight gap between upper and lower clamps at front.

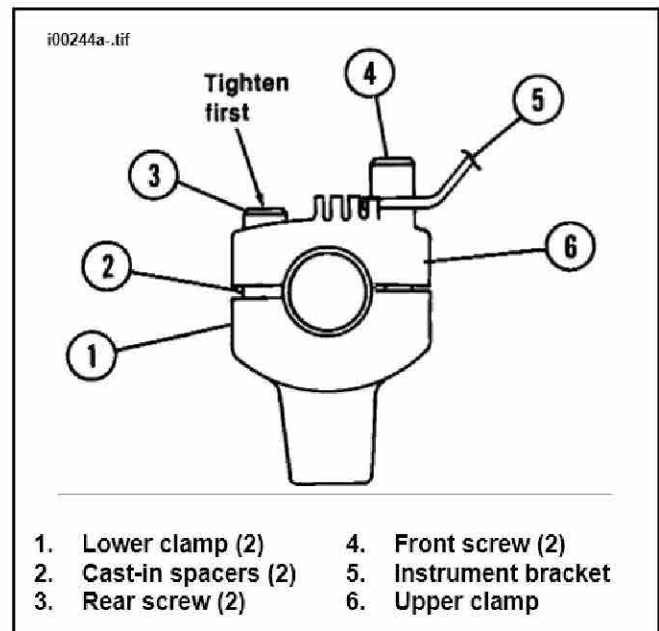

Figure 7. Handlebar Clamp

CAUTION

When handlebar installation is complete, the upper and lower clamps have contact with the cast-in boss in front and have a slight gap at the rear.

2. Connect the battery cables, positive cable first.
3. Turn ignition/light switch to ON. Check that the indicator lights, signal lights and headlamp all function properly.
4. Start the engine, check the tachometer operation and check that the indicator lights are working correctly.
5. If tachometer does not function, see Figure 4 and check that all wiring connections were correctly made.
6. Be sure steering turns lock-to-lock freely.
7. Test ride motorcycle to verify speedometer is functioning properly.
8. If speedometer does not function, see Figure 4 and check that all wiring connections were correctly made.

SEALED BUTT CONNECTORS

INSTALLING SEALED BUTT CONNECTORS

General

Butt splicing is a necessary procedure to replace many components. Proceed as follows:

- Strip 3/8 inch of insulation off the ends of the wires.
- See Figure 8. Insert wires into opposite ends of the butt splice connector. Insert wires into the connector until the stripped ends are in the metal insert. Since the size of the connectors varies with the wire gauge, reference the following chart to ensure properly sealed splices.

Gauge Wire	Connector Color	Connector Part Number
18-20	Red	70585-93
14-16	Blue	70586-93
10-12	Yellow	70587-93

- See Figure 9. Crimp the wires in the connector using the Packard Crimp Tool (HD-38125-8). Be sure to match the color or gauge wire marked on the butt splice connector with the corresponding crimp cavity on the crimp tool.

NOTE

If adjacent wires are being spliced, stagger the splices so that the butt splice connectors are spaced at different positions along the length of the wires.

⚠WARNING

- Use extreme caution when operating the UltraTorch UT-100 or any other radiant heating device. Read the manufacturer's instructions carefully before using the tool. Improper tool handling can result in personal injury and/or vehicle damage.
- Always keep hands away from tool tip area and heat shrink attachment.
- Avoid directing the heat toward any fuel system

component. Extreme heat can cause fuel ignition/explosion.

- Avoid directing heat toward any electrical system component other than the connectors on which heat shrink work is being performed.
 - Be sure to turn the "ON/OFF" switch to the "OFF" position after use.
- Using the UltraTorch UT-100 (HD-39969), Robinair Heat Gun (HD-25070) with heatshrink attachment (HD-41183) or other suitable radiant heating device, heat the crimped splice to encapsulate the butt splice connection.
 - See Figure 8. Apply heat from the center of the crimp out to each end until the meltable sealant exudes out both ends of the connector.

NOTE

It is acceptable for the splice to rest against the heat shrink tool attachment.

- Heat the center of the splice until the crimp indentations disappear and the tubing assumes a smooth, cylindrical appearance.

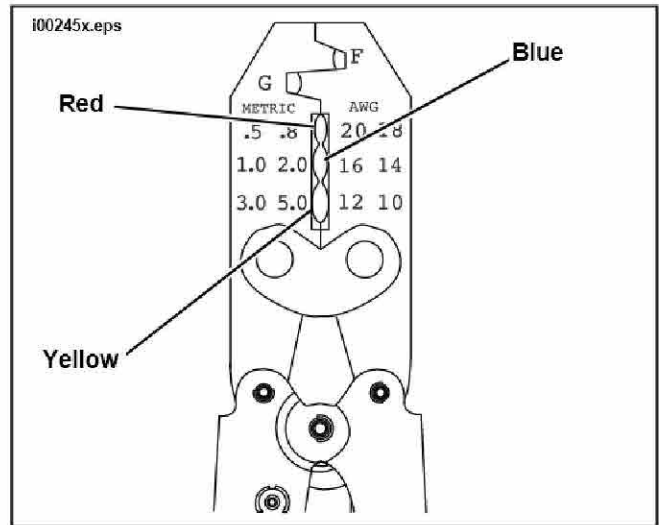

Figure 9. Packard Crimp Tool (HD-38125-8)

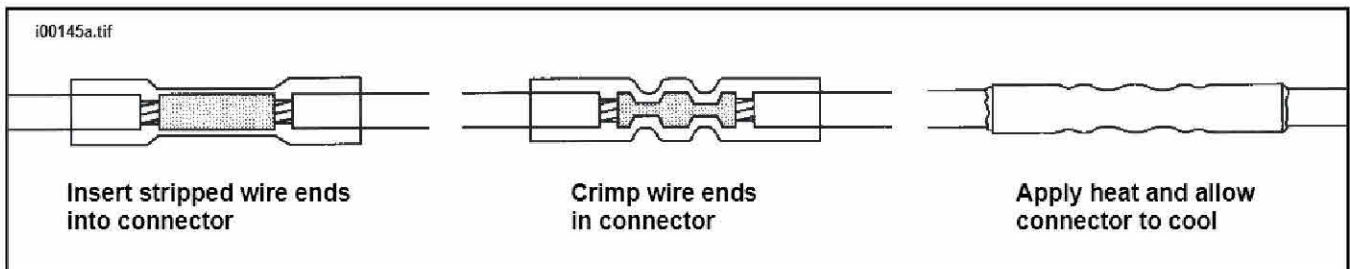

Figure 8. Install Sealed Butt Connectors



Service Parts

Part No. 67294-95

Date 9/94

Chrome Dual Gauge Kit

sp67294

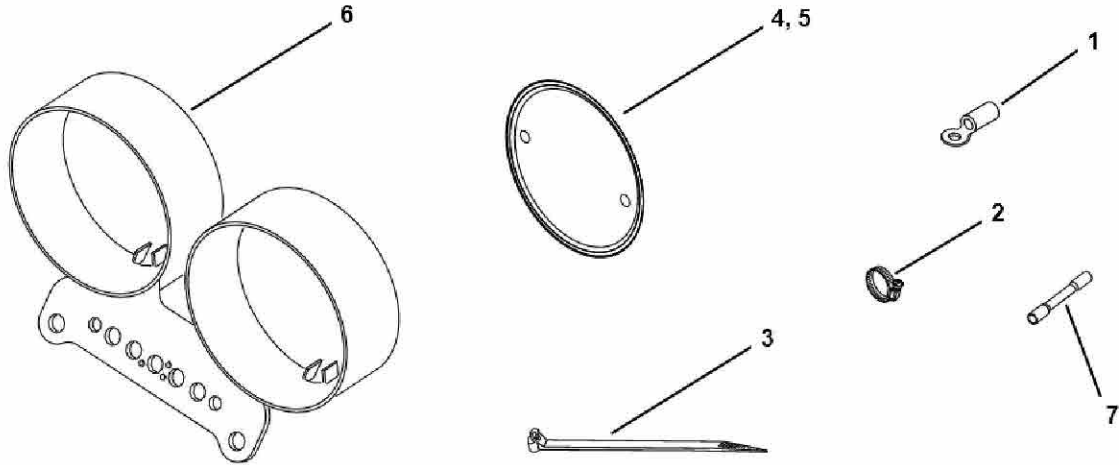

ITEM	DESCRIPTION	PART NO.
1	Ring terminal (4)	9857
2	Hose clamp (2)	9946
3	Cable strap (8)	10006
4	Cover, speedometer back	67336-95
5	Cover, tachometer back	67335-95
6	Gauge bracket, dual	67333-95
7	Butt connector (2)	70585-93

