



INSTRUCTIONS

-J00402

REV. 7-1-95

Kit Number 67109-86

TACHOMETER KIT

General

This kit is used on 1986 and later XLH model motorcycles equipped with handlebar mounted speedometers without tachometers.

NOTE

This kit can be installed on 1982 - 1985 XLX model motorcycles; however, the tachometer and speedometer graphics may not match.

Read all instructions carefully before you begin installation of the tachometer.

This kit contains:

QTY	DESCRIPTION
1	Tachometer assembly, with instrument mounting bracket
9	Connector
9	Conduit (shrink tubing)
5	Speednut
2	Terminal tabs (used on XLX only)
2	Pin, single socket (used on XLX only)
1	Trim plate

NOTE

One additional piece of each item, except the trim plate and tachometer assembly, is included to provide for the possibility of loss during installation.

Installation

⚠ WARNING

To prevent short circuits while installing this kit, disconnect the battery cables (negative cable first) before you begin the installation.

1. Disconnect speedometer cable from the speedometer.
2. Remove two acorn nuts from the rear of the speedometer. Remove the chrome plate and speedometer housing.
3. Gently pull the two bulb housing out of the rear of the speedometer.
4. Remove the speedometer from the speedometer bracket.

5. See Figure 1. Remove screw (1) from the outer clamping ring (2) and remove the sealed beam unit.
6. Remove the snap plug (3) on top of the headlamp bracket and remove the nut beneath it.
7. Remove two capscrews securing the headlamp bracket (4) and remove the bracket.
8. See Figures 2 and 3. Disconnect the electrical socket located on the top of the headlamp housing by pressing on the short sides of the connector boot and pulling upward.
9. Place an identifying number on each wire at two places, once near the indicator lights and again on the opposite end of the wire.
10. Cut through the conduit and the wires connected to the indicator lights at the midpoint of the wires.

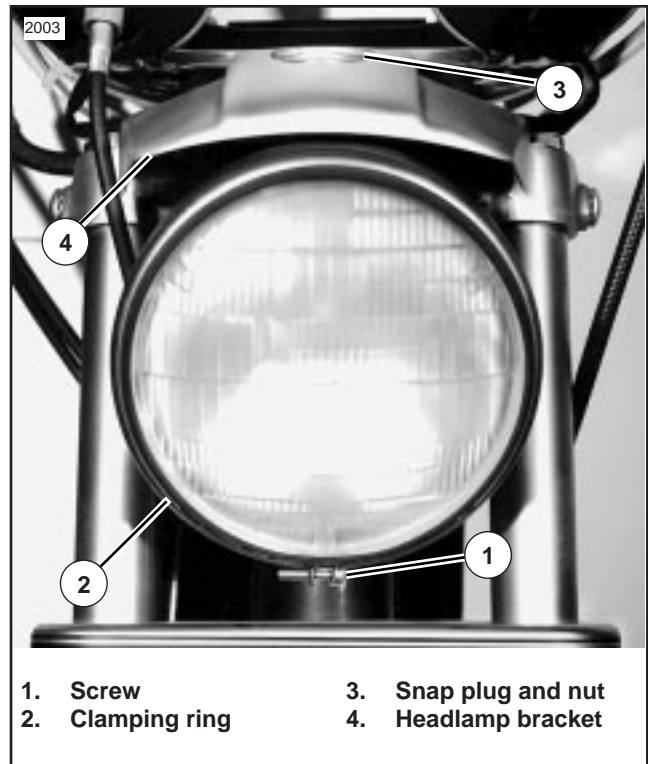

- | | |
|------------------|----------------------|
| 1. Screw | 3. Snap plug and nut |
| 2. Clamping ring | 4. Headlamp bracket |

Figure 1. Headlamp Mounting

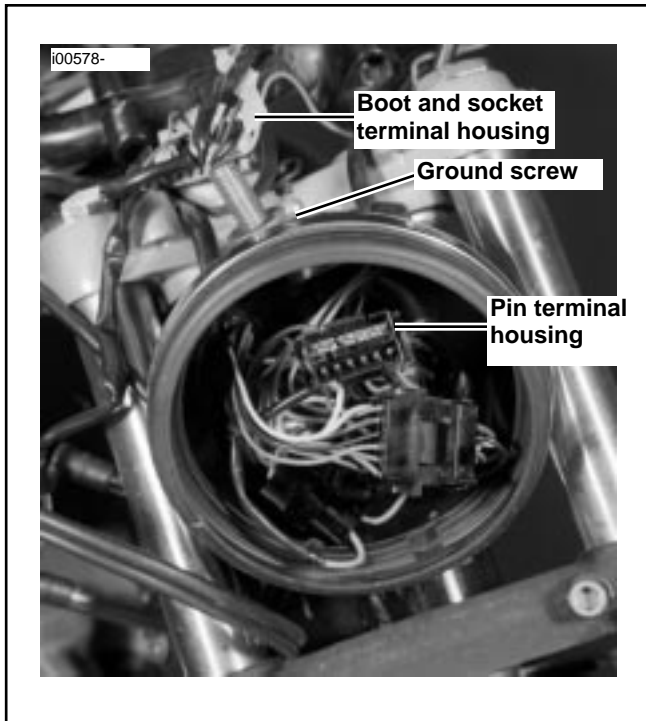

Figure 2. Headlamp Connector

NOTE

The number of indicator lights will vary depending on the year and model of your motorcycle.

11. Remove the speednuts from the indicator light wires in the speedometer bracket. Remove the indicator lights.
12. Install the indicator lights in the instrument mounting bracket contained in this kit. Secure the indicator lights with the speednuts provided with this kit.

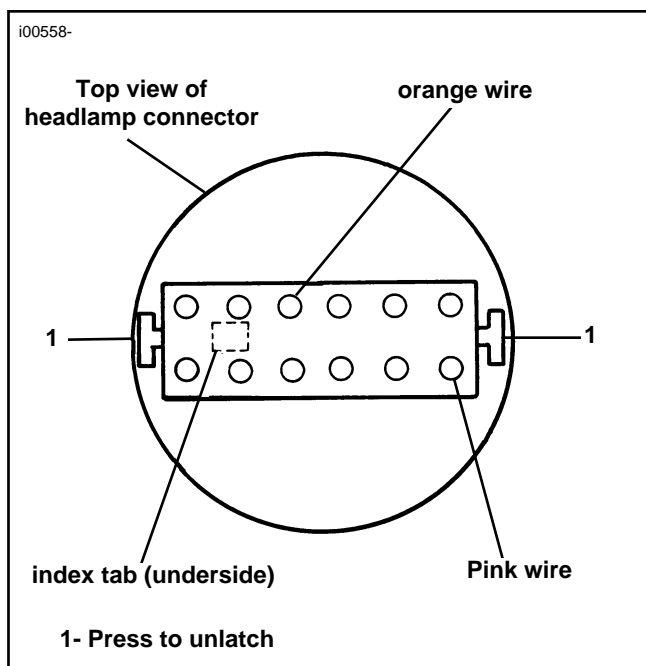

Figure 3. Tachometer Wiring

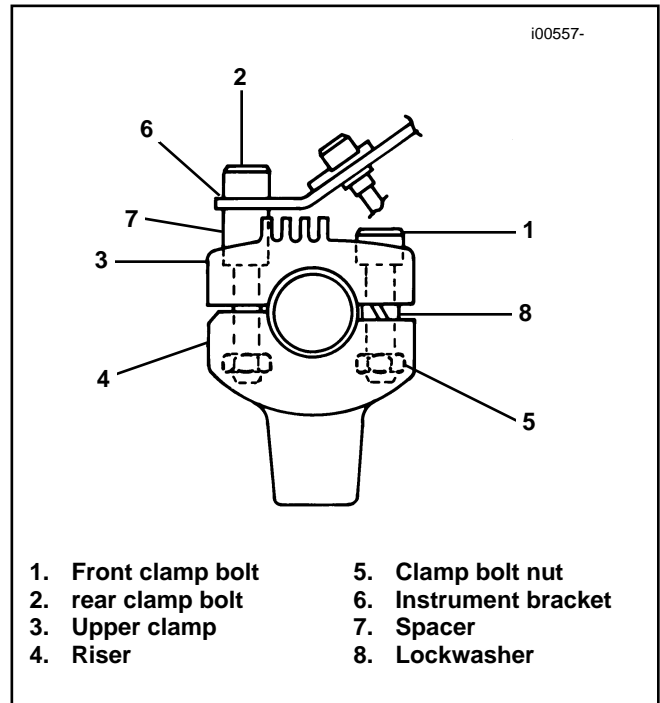

Figure 4. Instrument Bracket Mounting

NOTE

When removing the speedometer instrument bracket, keep in mind that bracket (6) and spacer (7) are mounted at the front and lockwasher (8) is mounted at the rear of the handlebar. These positions are reversed when installing the dual instrument bracket as shown in Figure 4.

13. See Figure 4. Remove the front and rear handlebar clamp bolts (1 and 2). Remove speedometer instrument bracket (6), spacers (7), and upper clamp (3).
14. Remove the two riser stud nuts at the underside of the upper fork bracket and move the handlebar clear of risers (4). Lift up the risers (4), with studs, and interchange the position of the two risers (left riser to the right and right riser to the left). Loosely thread on the riser stud nuts.
15. Mount the handlebar on risers (4) and position the upper handlebar clamp in alignment with holes in the riser (wide spaced holes at the rear of handlebar).
16. Place lockwasher (8) between upper clamp (3), if originally equipped, and each hole in riser (4) at the front side of the handlebar. Insert shorter clamp bolt (1) through upper clamp (3), lockwasher (8) and riser (4). Thread on clamp bolt nuts (5). Tighten bolts (1) to a torque of 12-15 ft-lbs.
17. Place the dual instrument bracket (6) in position over the rear holes in upper clamp (3). Place a spacer (7) under the bracket and over each rear hole in handlebar riser (4). Insert longer bolt (2) through bracket (6), spacer (7), upper clamp (3) and riser (4). Thread on clamp bolt nut (5) and tighten finger tight.
18. Tighten riser stud nuts to 25-30 ft-lbs.

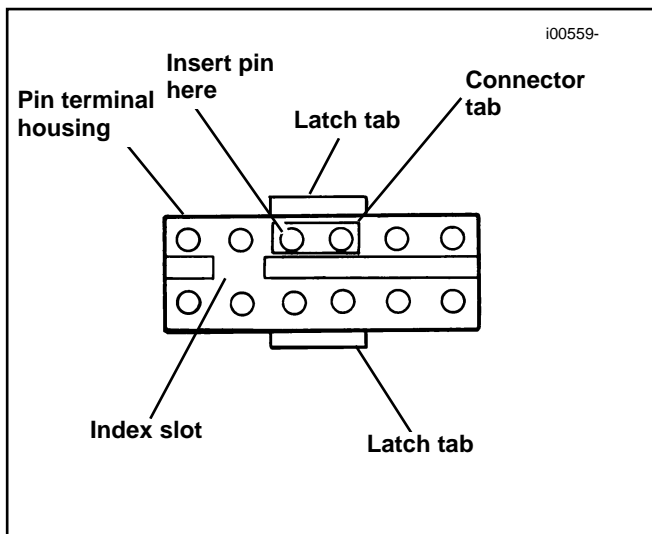

Figure 5. Connector Tab Location

Wiring Instructions - XLX

1. Depress the latch tabs of the pin terminal housing and remove the pin terminal housing from the headlamp housing.
2. See Figure 5. Crimp the end of a pin provided with this kit and insert it from the underside of the pin terminal housing in the location indicated.
3. See Figure 5. Place a terminal tab over the two pins indicated. Push the tab down to the base of the pins. Be certain that the tab does not touch adjacent tabs.
4. Install the pin terminal housing in the headlamp housing.

Indicator Light Leads Connection

1. See Figure 6. Position indicator lights in bracket as shown.
2. Strip 1/4 in. of insulation from the ends of the wires attached to the indicator lights.
3. Slip a piece of shrink tubing over one of the wires attached to the headlamp connector. (Push the piece of tubing into the conduit far enough to allow insertion of the stripped wire end into a connector.)
4. Place one end of a connector on each of the stripped wires and crimp it on the wire. Crimp only the half of the connector placed over the wire.
5. Insert the stripped other end of the wire into the connector attached to the opposite half of the same wire. Crimp the connector on the wire.
6. Slide the shrink tubing over the connector and into the conduit on the indicator light side of the connector.
7. With a heat gun, hair dryer, cigarette lighter or match, apply heat to the shrink tubing until it shrinks tightly around connector and wire.

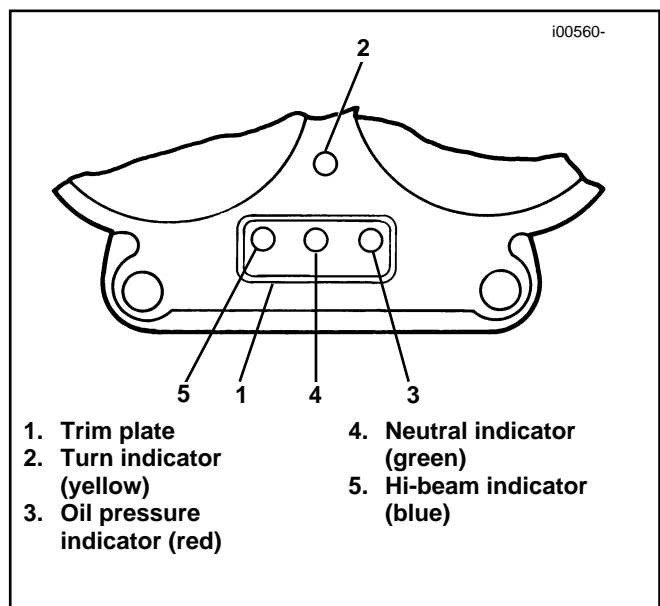

Figure 6. Indicator Light Locations

⚠ WARNING

If open flame is used, take precautions to prevent fire.

8. Repeat Steps 3 through 7 for the remaining indicator light wires.

Installing Instruments to Bracket

1. Install the rubber insulating ring from the kit in the instrument mounting bracket receptacle to the left side of the motorcycle. Make certain the cushion is positioned with the recesses for cover tabs at bottom of the bracket and facing forward (front of motorcycle). Slip the tachometer through the cushion.
2. See Figure 3. Puncture the socket connector boot with the sockets of the orange and pink tachometer wires at the locations shown and install the sockets through the boot into the socket connector at the proper locations. Make certain that the socket pin terminals are seated and locked in the socket terminal housing.
3. See Figure 2. Remove the ground screw holding a black wire on the upper triple clamp. Reconnect this black wire together with the black tachometer wire to the triple clamp. Tighten the screw to 15-21 in-lbs.
4. Connect the headlamp socket housing to the pin housing.
5. Install the tachometer cover and chrome plate. Secure cover and plate with two acorn nuts.
6. Install the speedometer using the rubber insulating ring from the speedometer bracket.
7. Insert the speedometer bulb housings and install the cover and chrome plate. Secure cover and plate with two acorn nuts.

- See Figure 7. Adjust the handlebar to the normal riding position. While holding the handlebar, tighten the rear screws to 12-15 ft-lbs.

CAUTION

When installation of the handlebar is complete, the upper and lower clamps have contact with the washer in front and have a slight gap at the rear.

- Connect the battery cables, positive cable first.
- Turn ignition/light switch to ON. Check that the indicator lights, signal lights and headlamp all function properly.
- Start the engine, check the tachometer operation, and check that the indicator lights are working.
- Before riding the motorcycle, adjust the headlamp beam. Refer to the applicable Service Manual for instructions.

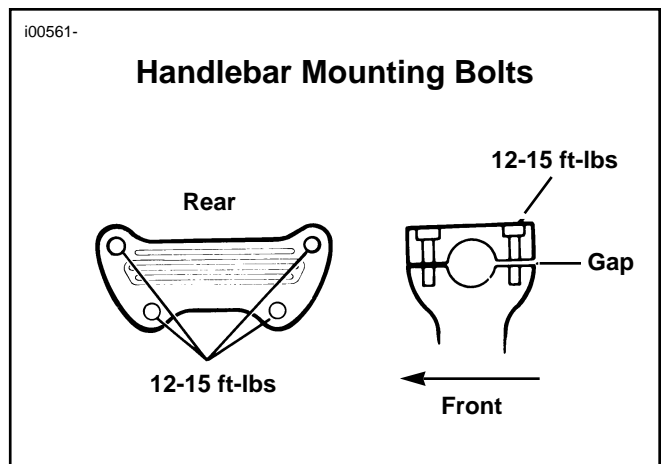

Figure 7. Handlebar Mounting