



INSTRUCTIONS

-J00311

REV. 8-1-95

Kit Numbers 58058-94, 58065-94, and 58316-95

WINDSHIELD KITS

General

Kit numbers **58058-94** and **58065-94** (low profile) are designed for installation on 1988 and later XLH, FXD models and 1987 through 1994 FXR, FXLR and FXRS-SP models.

Kit number **58316-95** (smoked, low profile) is designed to replace king size windshields on 1984 and later FLSTC models and 1990 and later FLSTN, FLSTF models.

Each kit contains:

QTY	DESCRIPTION
1	Windshield
1	Window, adjustable
2	Tape for horizontal braces (5 holes)
2	Tape for vertical braces (2 holes)

Installation

1. See illustration. Remove old windshield from motorcycle.
2. Remove all hardware that secures mounting brackets to windshield. The nine screws must be removed with a T-27 TORX screwdriver. Save all hardware and brackets for installing new windshield.
3. Remove all old tape from brackets and apply new tape (1) from kit onto brackets (2). Align holes in tape with holes in brackets.

CAUTION

Do not over tighten fasteners in step 4. Over tightening can crack the windshield.

4. Install all brackets (2) and tighten all screws and acorn nuts to 4-5 ft-lbs.
5. Install new windshield (3) on motorcycle.
6. Adjust window (4) so bottom edge does not touch headlamp.

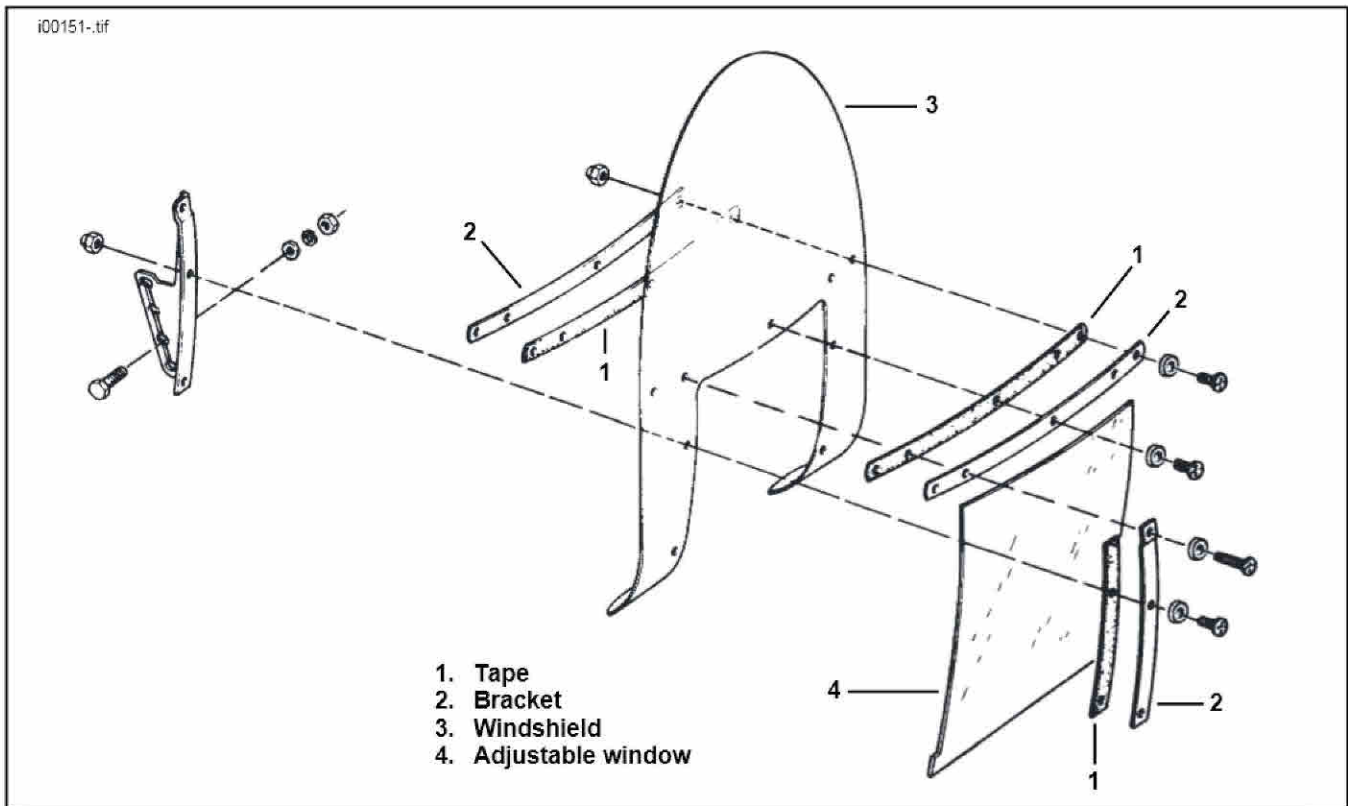

Illustration. Exploded View Of Windshield



Service Parts

Part No. See below.

Date 8/95

Windshield Kits

i00151-.tif

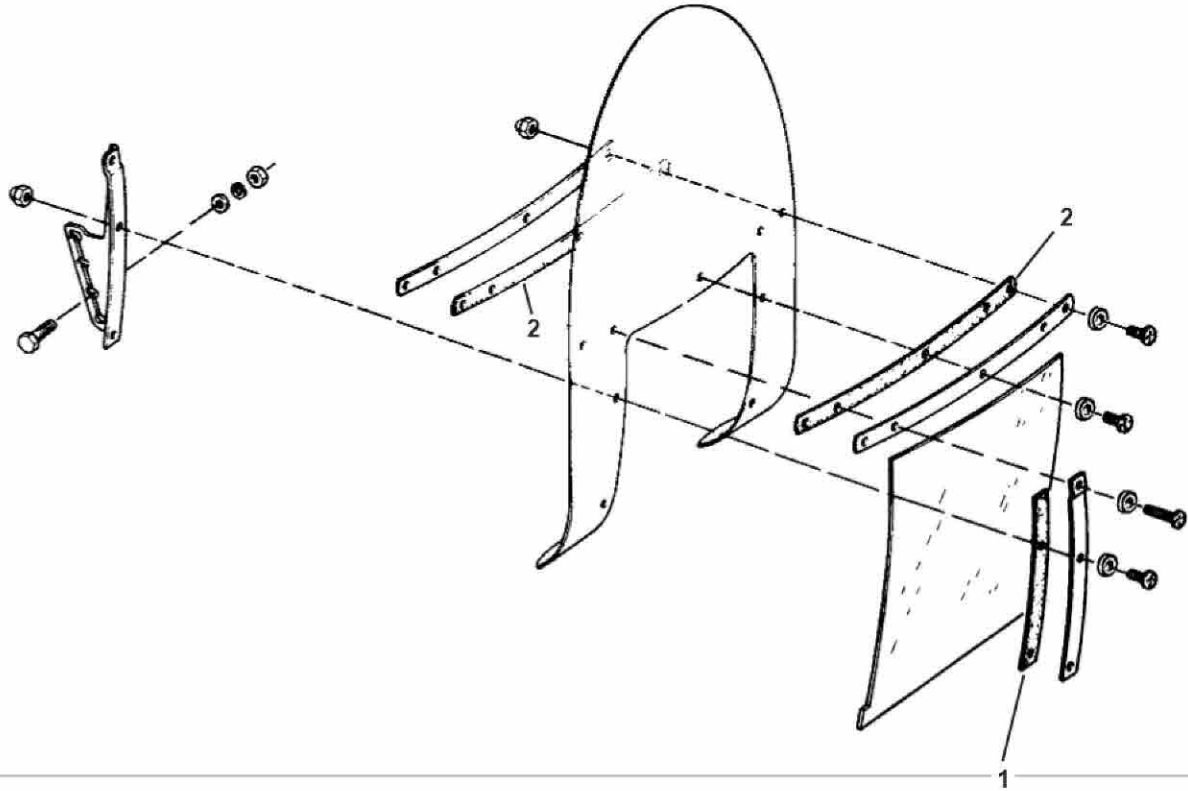

Part No. 58058-94, 58065-94

Part No. 58316-95

Item	Description	Part No.	Item	Description	Part No.
1	Tape for vertical braces	58417-77	1	Tape for vertical braces	58417-77
2	Tape for horizontal braces	58052-78	2	Tape for horizontal braces	58416-77A