



INSTRUCTIONS

-J00309

REV. 2005-11-17

DETACHABLE WINDSHIELD AND DOCKING HARDWARE KIT

GENERAL

Kit Number

57715-01, 57716-01, 577960-97, 58034-96, 58112-96, 58164-96A, 58357-96, 58367-96, 58441-96, 58570-96, 58626-99

Models

Table 1. Models

Kits	Models
57715-01	Standard-height smoked-windshield assembly for 1988 and later XL, FXR and FXD models equipped with accessory passing lamps.
57716-01	Standard-height clear-windshield assembly for 1988 and later XL, FXR and FXD models equipped with accessory passing lamps.
57960-97	Super Sport smoked-windshield assembly for 1988 and later XL, FXR, and FXD models.
58034-96	Standard-height clear-windshield assembly for 1988 and later XL, FXR, and FXD models, except XL Custom and FXLR models.
58112-96	Low-profile smoked-windshield assembly for 1988 and later XL, FXR, and FXD models, except XL Custom and FXLR models.
58357-96	Standard height clear-windshield assembly for 1996 and later XL Custom and 1987-1994 FXLR models.
58367-96	Low-profile smoked-windshield assembly for 1996 and later XL Custom and 1987-1994 FXLR models.
58441-96	Standard-height smoked-windshield assembly for 1988 and later XL, FXR, and FXD models.
58570-96	Standard-height clear-windshield assembly for 1988 and later XL, FXR, and FXD models.
58626-99	Standard-height smoked-windshield assembly for 1988 and later XL, FXR and FXD models, except XL Custom and FXLR models.
58164-96A	The docking hardware required to mount any of the above windshields.

Additional Parts Required

On models equipped with passing lamps, the turn signals must be relocated under the passing lamps using **Turn Signal Relocation Kit 68603-01**, available separately from any Harley-Davidson dealer. Refer to the Instruction Sheet provided with that kit for relocation procedures, then go to "Windshield Installation" in this Instruction Sheet.

If the front turn signals are mounted on the **UPPER fork bracket**, the turn signals must be relocated to the LOWER fork bracket. using **Turn Signal Relocation Kit 72389-96**, available separately from any Harley-Davidson dealer.

WARNING

The rider's safety depends upon the correct installation of this kit. Use the appropriate service manual procedures. If the procedure is not within your capabilities or you do not have the correct tools, have a Harley-Davidson dealer perform the installation. Improper installation of this kit could result in death or serious injury. (00333a)

NOTE

This instruction sheet references Service Manual information. A Service Manual for your model motorcycle is required for this installation and is available from a Harley-Davidson Dealer.

Kit Contents

See the Service Parts Illustration and Table for your kit.

INSTALLATION

If the front turn signals are mounted on the **UPPER fork bracket**, relocate the turn signals to the LOWER fork bracket following the instructions in the Turn Signal Relocation Kit 72389-96, (sold separately), then proceed to "Windshield Installation" below.

If the front turn signals **ARE NOT** mounted on the upper fork bracket, proceed to "Windshield Installation"

Windshield Installation

NOTE

Place shop rags on the headlamp, front fender and front of the fuel tank to prevent scratches to these components. Be sure the windshield assembly does not contact chrome or painted parts. Contact will cause scratches to chrome or painted parts.

1. See Figure 1. Relocate the clutch cable to the inside of the handlebars as follows:
 - a. Slide the rubber boot off the cable adjuster. The adjuster is located approximately halfway along the clutch cable near the front frame downtube.
 - b. Holding the cable adjuster with a 1/2-inch wrench, loosen the jam nut using a 9/16-inch wrench. Back the jam nut away from the cable adjuster. Move the adjuster toward the jam nut to introduce a large amount of freeplay at the hand lever.
 - c. Remove the small snap ring from the pivot-pin groove at the bottom of the clutch lever bracket. Remove the pivot pin and clutch hand lever from the bracket.
 - d. Reroute the clutch cable to the inside of the handlebars as shown, and reconnect the clutch cable to the clutch lever by reversing Step "c".
 - e. Turn the cable adjuster away from the jam nut until slack is eliminated at the hand lever. Pull the clutch cable ferrule away from the clutch lever bracket to check the free play. Turn the cable adjuster as necessary to obtain 1/16 to 1/8 inch (1.6-3.2 mm) free play between the end of the cable ferrule and the clutch lever bracket as shown in Figure 2.
 - f. Hold the adjuster with a 1/2-inch wrench. Using a 9/16-inch wrench, tighten the jam nut against the cable adjuster. Cover the cable adjuster mechanism with the rubber boot.

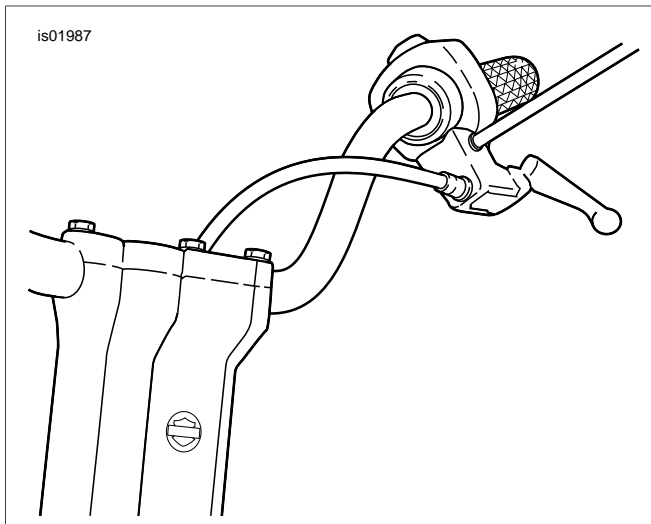

Figure 1. New Clutch Cable Routing

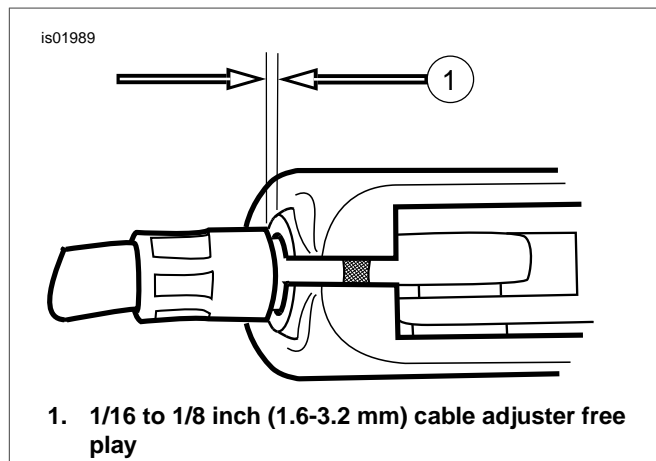

Figure 2. Clutch Cable Adjustment

2. For handlebar styles other than buckhorn pullbacks, see Figure 3. Use the wireform (1) from the Docking Hardware Kit to secure the throttle cables to the upper mounting clamp as shown. Place the chrome washer (2) from the kit between the wireform and the mounting clamp nut.

For buckhorn-style handlebars, see Figure 4. Use the wireform (1) from the Docking Hardware Kit to secure the throttle cables to the upper fork triple clamp as shown.

- For XL Custom or FXLR models, use the original socket head screw (4) and washer (3) over the wireform, and the washer (2) from the kit underneath.
- For all other models, use the socket head screw (4) from the kit and the original washer (3) over the wireform, and the washer (2) from the kit underneath.

⚠ WARNING

Before starting engine, be sure throttle control will snap back to idle position when released. A throttle control that prevents engine from automatically returning to idle can lead to loss of control, which could result in death or serious injury. (00390a)

⚠ WARNING

Be sure that steering is smooth and free without interference. Interference with steering could result in loss of vehicle control and death or serious injury. (00371a)

3. For vehicles equipped with passing lamps, install the Turn Signal Relocation Kit following the instructions provided in that kit prior to performing the following steps.
4. See the Docking Hardware Service Parts illustration. Assemble the mounting hardware for the lower windshield mounting as shown.
 - For models equipped with passing lamps, install the lower mounting clamp approximately 1-3/4 inch (44 mm) above the lower fork triple clamp with the clamp nuts facing toward the rear of the motorcycle.
 - For models not equipped with passing lamps, install the lower mounting clamp approximately 1/2 inch (13 mm) above the lower fork triple clamp with the clamp nuts facing toward the rear of the motorcycle.

- Tighten the clamp nuts to 10 ft-lbs (14 Nm). Be sure the clamp does not rotate during tightening (the mounting bushing must be parallel to the windshield brackets). Tighten the button head screws (item 4 in the Docking Hardware Parts List) to 15 ft-lbs (20 Nm).

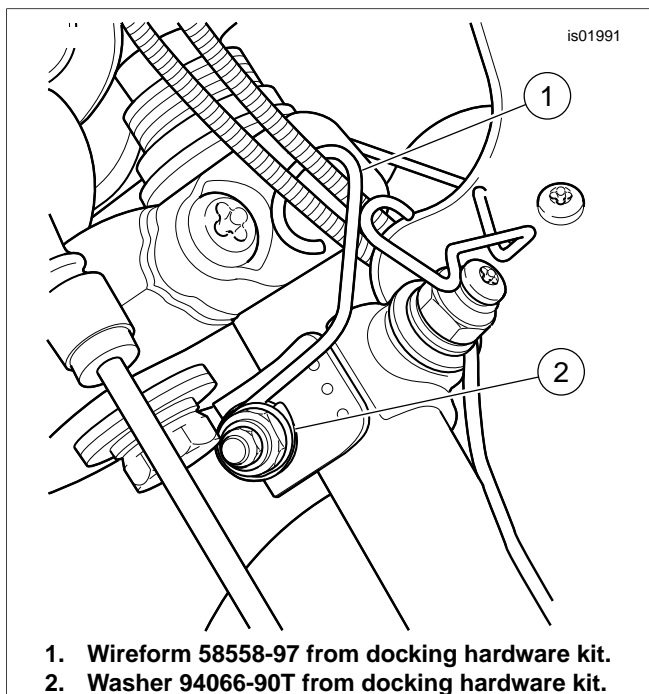

Figure 3. Throttle Cable Attachment (All Handlebars Except Buckhorn-Style) (View Looking Upward)

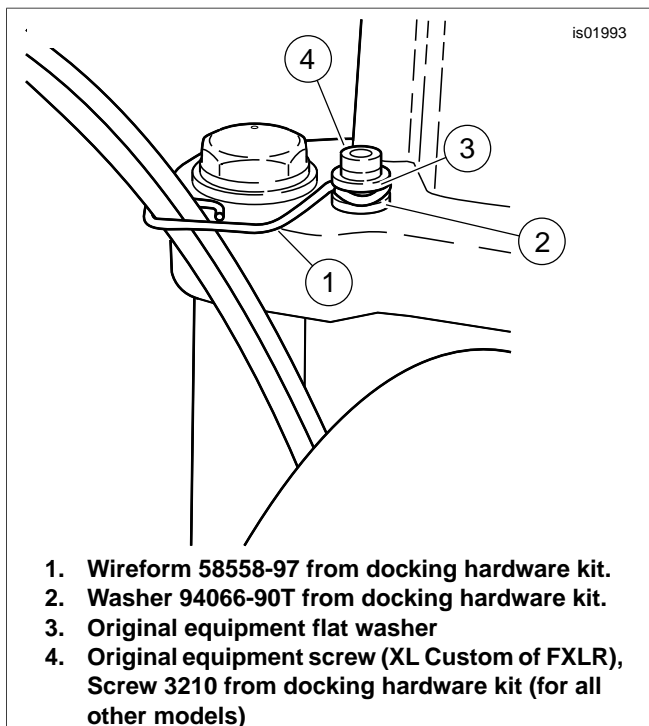

Figure 4. Throttle Cable Attachment (Buckhorn-Style Pullback Handlebars)

- Assemble the hardware for the upper windshield mounting as shown. Leave the clamp nuts loose so the clamps can be slid up and down the fork tubes to allow for proper adjustment.

- Hook the two lower windshield assembly jaws into the grooves of the lower bushings, then slide the upper clamp assemblies into place until the upper bushings fit firmly into the upper windshield jaws.
- With the windshield in place, tighten the upper clamp nuts to 10 ft-lbs (14 Nm). Be sure the clamp does not rotate during tightening (the mounting bushing must be parallel to the windshield brackets).

NOTE

Inspect the windshield for proper adjustment in relation to the headlamp opening. If necessary, adjust the mounting clamps up or down for proper headlamp to windshield relationship.

WARNING

Improper installation of accessories or loading of cargo can affect motorcycle stability and handling, which could result in death or serious injury. (00455b)

WARNING

Failure to provide adequate clearance between stationary and moving parts can cause loss of control, which could result in death or serious injury. (00378a)

NOTE

Check mounting hardware periodically. Never ride with loose mounts. A loose mounting causes extra stress on all other mounts, as well as the windshield itself, and could result in premature failure of components.

Care and Cleaning

NOTE

Sunlight reflections off of the inside curvature of a windshield can, at certain times of the day, cause extreme heat build-up on motorcycle instruments. Exercise care in parking. Park facing the sun, place an opaque object over the instruments, or adjust the windshield to avoid reflections.

NOTICE

Harley-Davidson windshields are made of Lexan. Lexan is a more durable and distortion-resistant material than other types of motorcycle windshield material, but still requires attention and care to maintain. Failure to maintain Lexan properly can result in damage to the windshield. (00230a)

NOTE

Do not clean Lexan® polycarbonate in hot sun or high temperature. Powdered, abrasive or alkaline cleanser will damage the windshield. Never scrape the windshield with a razor blade or other sharp instruments because permanent damage will result.

NOTICE

Do not use harsh chemicals including rain sheeting products on Harley-Davidson windshields. They can cause dulling or hazing. If you want to use a windshield protectant on your windshield, try Harley Glaze Polish and Sealant (00231a)

NOTICE

Do not use benzine, paint thinner, gasoline or any other type of harsh cleaner on the windshield. Doing so will damage the windshield surface. (00232a)

- Do not use benzine, paint thinner, gasoline, lubricants

(including Armorall®), or other cleaning agents on the rubber bushings. They will damage the bushing surfaces.

NOTE

Covering the windshield with a clean, wet cloth for about 15 minutes before washing will make dried bug removal easier.

SERVICE PARTS

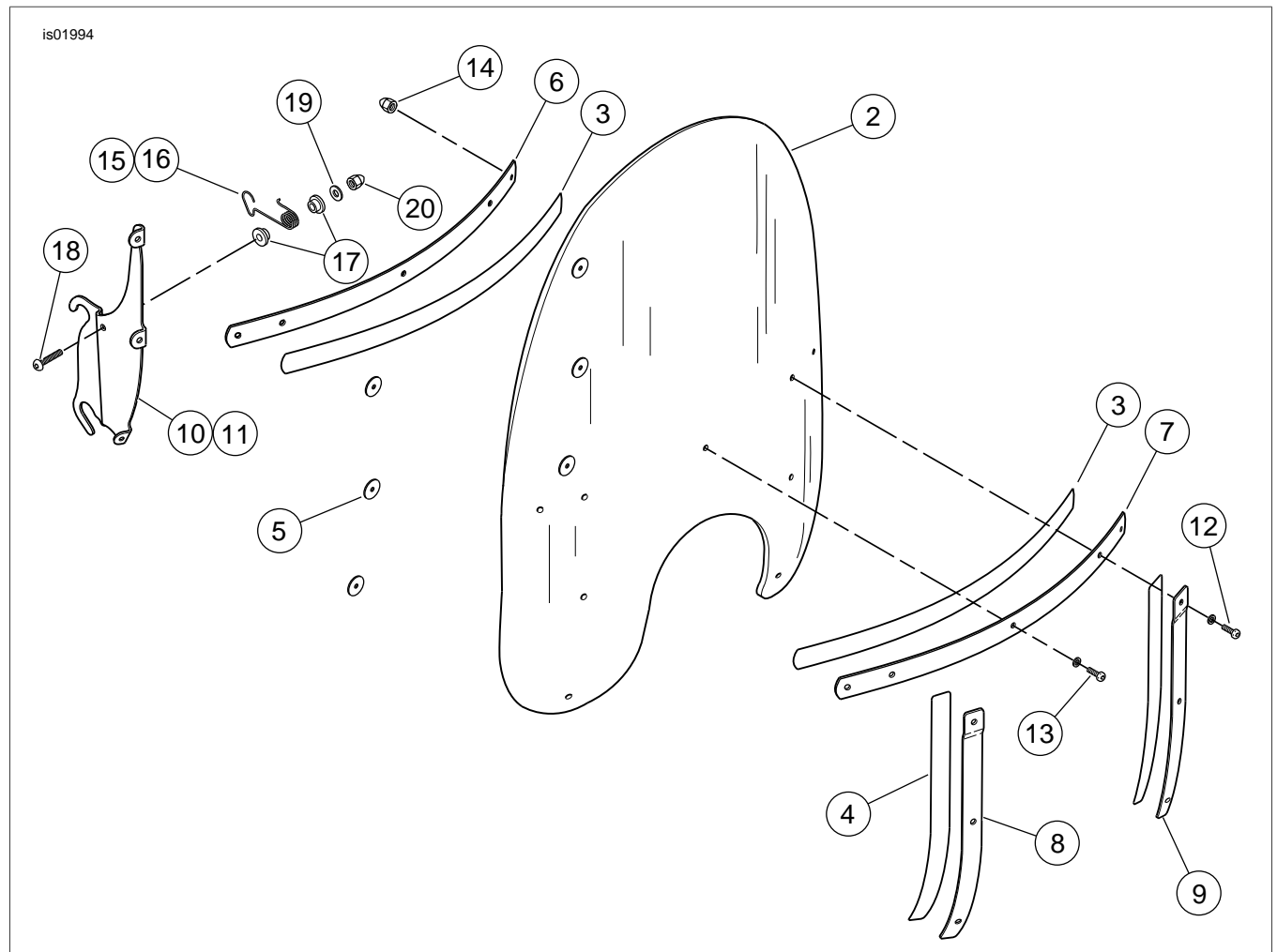

Figure 5. Service Parts 1: Windshield Kits

Table 2. Service Parts Table

Item	Description (Quantity)	Part Number	Item	Description (Quantity)	Part Number
Kits 58034-96, 58112-96, 58357-96, 58367-96, 58626-99					
NOTE: Appearance of actual components may vary from illustration.					
1	Windshield service kit (includes items 2 through 5)		10	Bracket, windshield (right)	58122-96
	For kit 58034-96 (standard, clear)	58061-96	11	Bracket, windshield (left)	58116-96
	For kit 58112-96 (low profile, smoked)	58103-96	12	Screw, pan head, Torx (2) #12-24 x 13/16 in. long	2452
	For kit 58357-96 (standard, clear)	58358-96	13	Screw, pan head, Torx (7) #12-24 x 5/8 in. long	2921
	For kit 58367-96 (low profile, smoked)	58368-96	14	Acorn nut, #12-24 (chrome) (9)	7651
	For kit 58626-99 (standard, smoked)	58625-99	15	Windshield retainer, wireform (right)	58266-95
2	Windshield	Not Sold Separately	16	Windshield retainer, wireform (left)	58259-95
3	Tape, horizontal (2)	58052-78	17	Bushing, Nylon (4)	58272-95
4	Tape, vertical (2)	58417-77	18	Screw, button head (chrome) (2)	94426-95
5	Washer, black rubber (6)	58152-96	19	Flat washer, 1/4 in. (silver) (2)	6703

Table 2. Service Parts Table

Item	Description (Quantity)	Part Number	Item	Description (Quantity)	Part Number
6	Brace, windshield horizontal (inner)	58050-78A	20	Acorn nut, 1/4-20 (chrome) (2)	94004-90T
7	Brace, windshield horizontal (outer)	58051-78A			
8	Brace, windshield outer (right)	58406-75A			
9	Brace, windshield outer (left)	58408-75A			

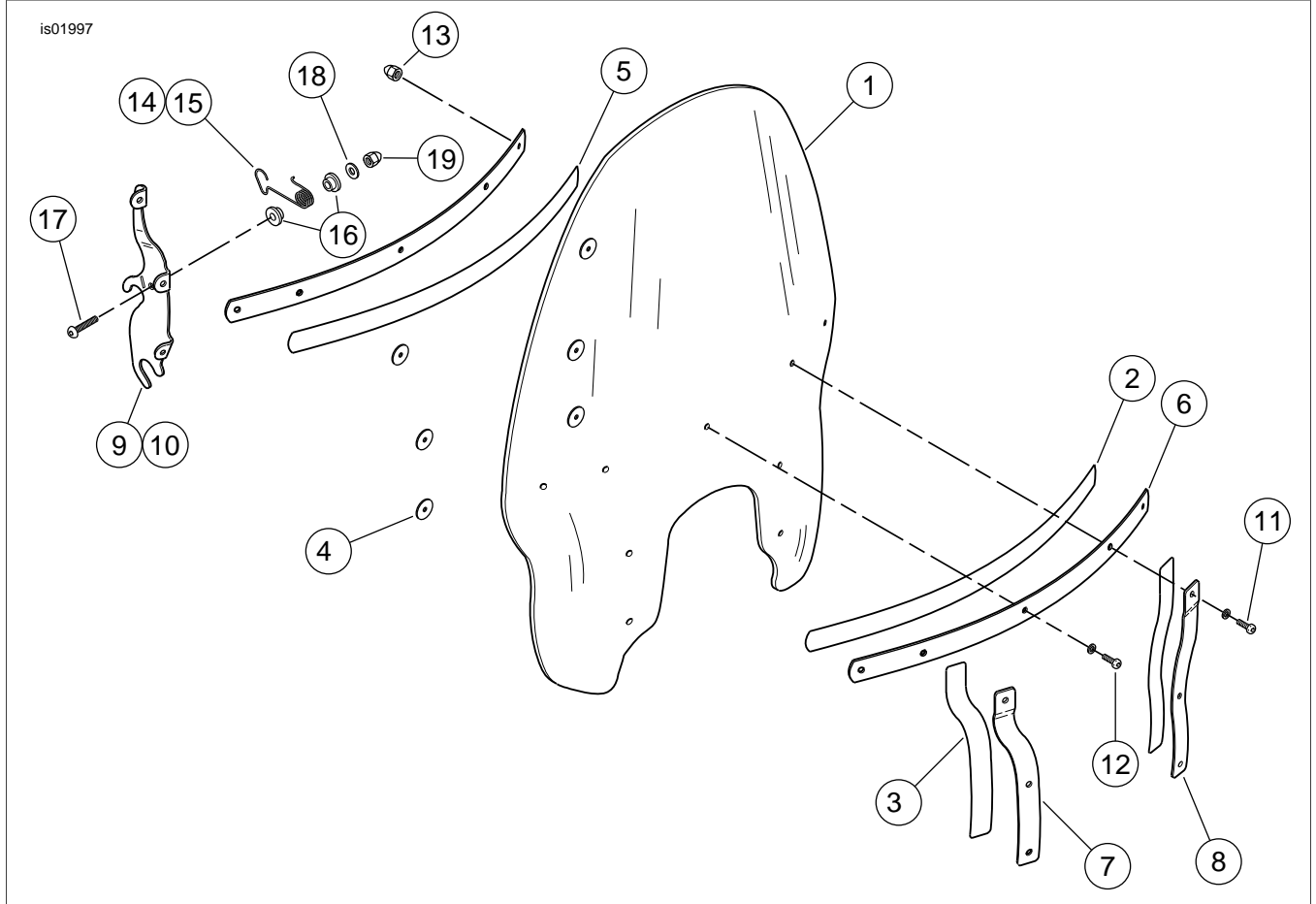

Figure 6. Service Parts 2: Windshield Kits

Table 3. Service Parts Table

Item	Description (Quantity)	Part Number	Item	Description (Quantity)	Part Number
Kits 58570-96 and 58441-96					
NOTE: Appearance of actual components may vary from illustration.					
1	Windshield	Not Sold Separately	11	Screw, pan head, Torx (2) #12-24 x 13/16 in. long	2452
2	Tape, horizontal	58582-96	12	Screw, pan head, Torx (7) #12-24 x 5/8 in. long	xxxxx-xx
3	Tape, vertical	58583-96	13	Acorn nut, #12-24 (chrome) (9)	7651
4	Washer, black rubber (6)	58152-96	14	Windshield retainer, wireform (right)	58580-96A
5	Brace, windshield horizontal (inner)	58578-96	15	Windshield retainer, wireform (left)	58579-96A
6	Brace, windshield horizontal (outer)	58577-96	16	Bushing, Nylon (4)	58272-95
7	Brace, windshield outer (right)	58575-96	17	Screw, button head (chrome) (2)	94426-95
8	Brace, windshield outer (left)	58576-96	18	Flat washer, 1/4 in. (silver) (2)	6703
9	Brace, windshield (right)	58573-96	19	Acorn nut, 1/4-20 (chrome) (2)	94004-90T
10	Brace, windshield (left)	58574-96			

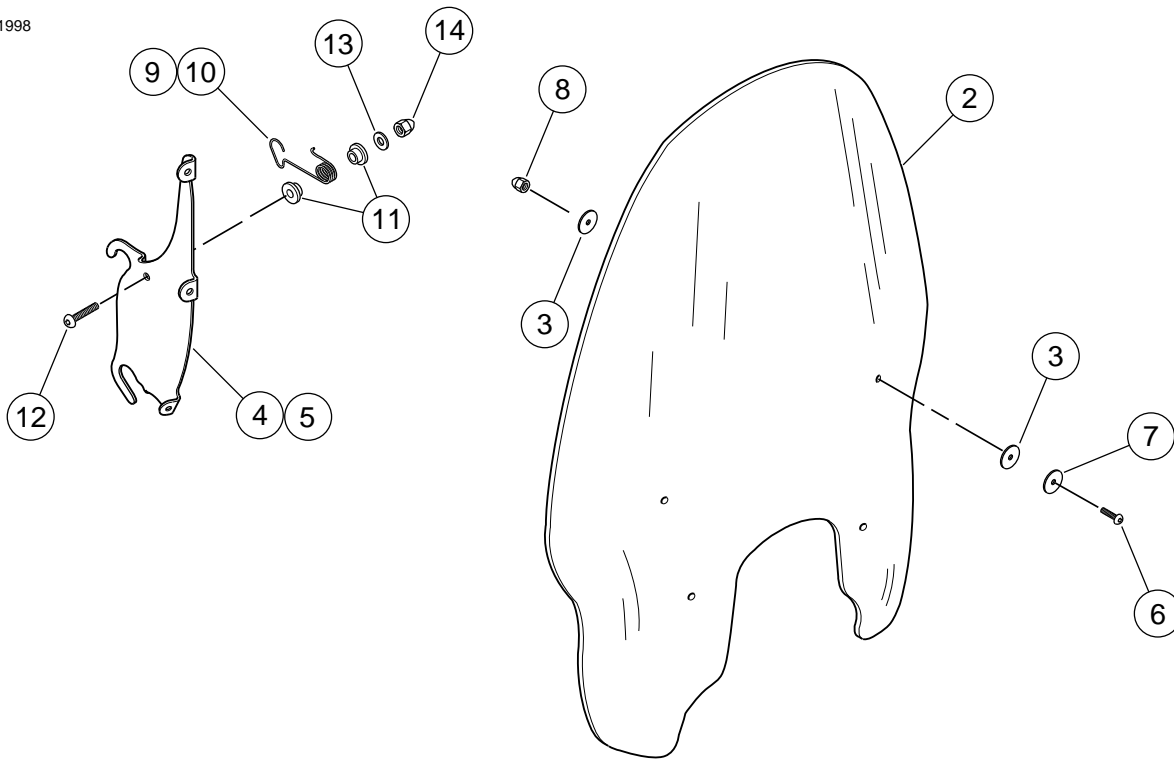

Figure 7. Service Parts 3: Windshield Kits

Table 4. Service Parts Table

Item	Description (Quantity)	Part Number	Item	Description (Quantity)	Part Number
Kit 57960-97					
1	Windshield service kit (includes items 2 and 3)	57730-98	8	Acorn nut, 5/16-24 (chrome) (4)	94007-90T
2	Windshield	Not Sold Separately	9	Windshield retainer, wireform (right)	58580-96A
3	Washer, black rubber (8)	58152-96	10	Windshield retainer, wireform (left)	58579-96A
4	Bracket, windshield (right)	57963-97	11	Bushing, Nylon (4)	58272-95
5	Bracket, windshield (left)	57962-97	12	Screw, button head (chrome) (2)	94426-95
6	Screw, button head, chrome w/lock patch (4)	94639-99	13	Flat washer, 1/4 in. (silver) (2)	6703
7	Washer, chrome (4)	6352	14	Acorn nut, 1/4-20 (chrome) (2)	94004-90T

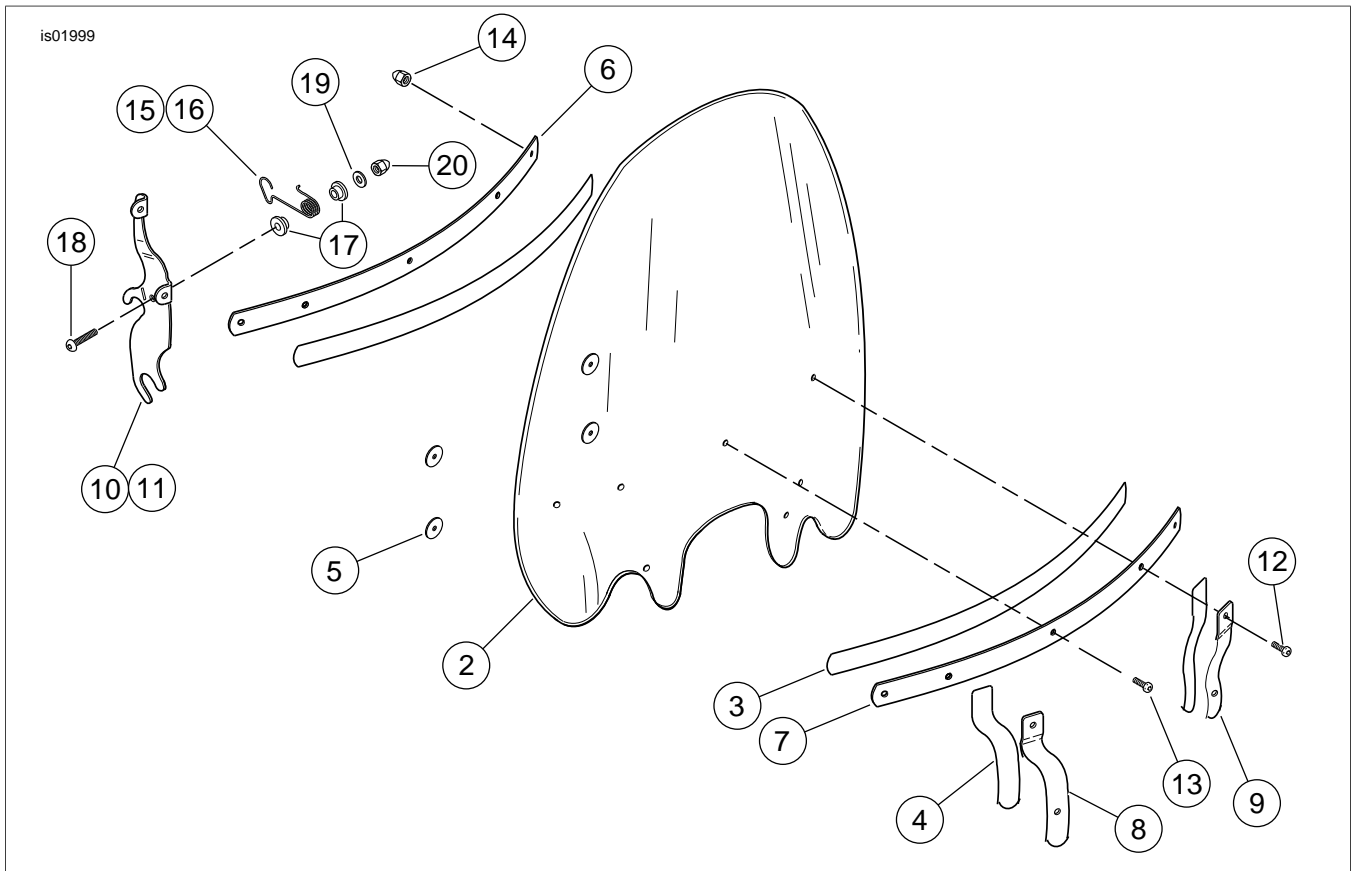

Figure 8. Service Parts 4: Windshield Kits

Table 5. Service Parts Table

Item	Description (Quantity)	Part Number	Item	Description (Quantity)	Part Number
Kits 57715-01 and 57716-01					
1	Windshield service kit (includes items 2 through 5) for kit 57715-01 (low profile, smoked)		11	Brace, windshield (left)	57711-01
	for kit 57716-01 (standard height, clear)	57718-01	12	Screw, pan head, Torx (2) #12-24 x 13/16 in. long	2452
	for kit 57715-01 (standard height, smoked)	57717-01	13	Screw, pan head, Torx (5) #12-24 x 5/8 in. long	2921
2	Windshield	Not Sold Separately	14	Acorn nut, #12-24 (chrome) (7)	7651
3	Tape, horizontal (2)	58052-78	15	Windshield retainer, wireform (right)	58580-96A
4	Tape, vertical (2)	57714-01	16	Windshield retainer, wireform (left)	58579-96A
5	Washer, black rubber (6)	58152-96	17	Bushing, Nylon (4)	58272-95
6	Brace, windshield horizontal (inner)	58050-78A	18	Screw, button head (chrome) (2)	94426-95
7	Brace, windshield horizontal (outer)	58051-78A	19	Flat washer, 1/4 in. (silver) (2)	6703
8	Brace, windshield outer (right)	57712-01	20	Acorn nut, 1/4-20 (chrome) (2)	94004-90T
9	Brace, windshield outer (left)	57713-01			
10	Brace, windshield (right)	57710-01			

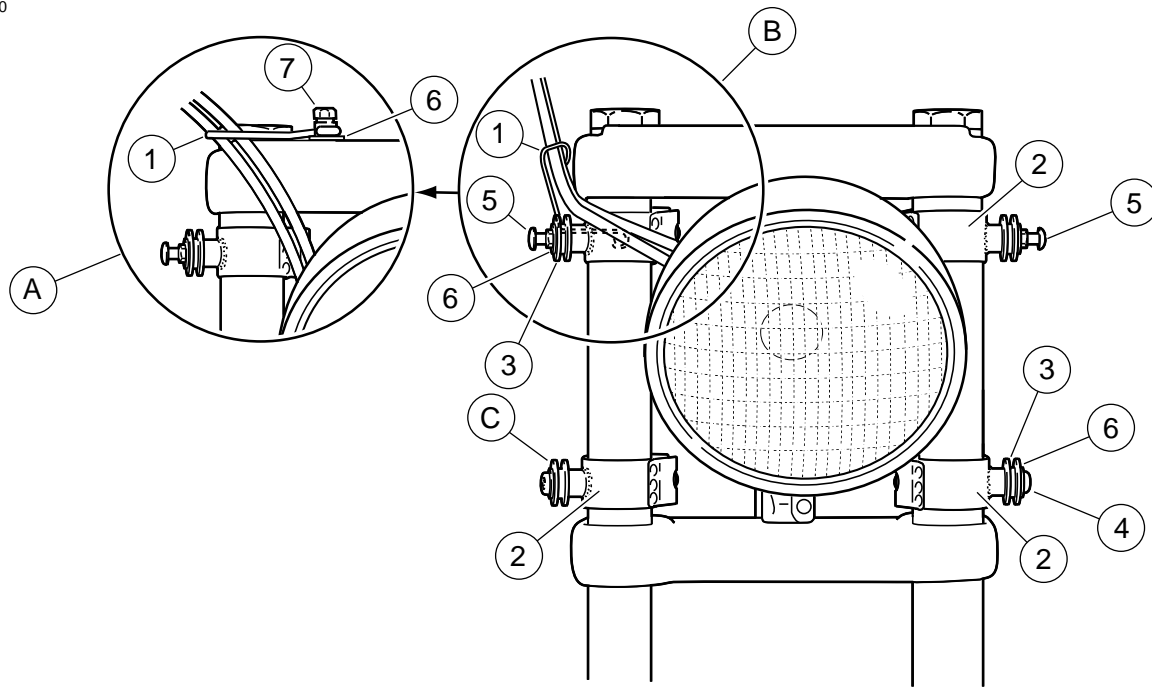

Figure 9. Service Parts 5: Windshield Locking Hardware Kit

Table 6. Service Parts Table

Item	Description (Quantity)	Part Number
Windshield Docking Hardware Kit 58164-96A		
1	Wireform	58558-97
2	Mounting clamp (4)	58124-96
3	Bushings (4)	67621-94
4	Button head screw (2), 5/16-24 x 5/8 in. long	94468-94T
5	Mushroom fastener (2)	58172-96
6	Flat washer, chrome (5)	94066-90T
7	Socket head screw, 5/16-18 x 1.25 in. long	3210A
Items mentioned in text, but not included in kit:		
A	Upper windshield mounting for Buckhorn-style pullback handlebars.	
B	Upper windshield mounting for handlebar styles other than Buckhorn-style.	
C	Lower windshield mounting	