



INSTRUCTIONS

-J00009

REV. 9-1-88

Kit Number 18210-84B

PERFORMANCE VALVE SPRING KIT

General

This kit is designed for use on all big twins 1984 and later and 1986 and later Sportster models.

The kit contains the following parts:

QTY	DESCRIPTION
4	Valve spring unit
8	Key, valve spring collar
4	Collar, valve spring lower
4	Collar, valve spring upper
1	Seal driver

NOTE

To properly install this kit you must have a Service Manual that covers your model. Service Manuals are available at your nearest authorized Harley-Davidson dealer.

Installation

1. Refer to the Service Manual and follow the procedure under Stripping the Motorcycle for Engine Repair.
2. Remove cylinder heads.
3. Compress valve springs and remove upper collar keys, upper collar, seal and lower collar on all four valves.

NOTE

If valves are removed, mark them to ensure installation in original locations.

4. See Figure 1. Install valves (in original locations), lower valve spring collars, upper collars and collar keys. Check installed spring height. Add shims or remove material from lower collar seat to reach 1.600" installed spring height. Remove upper collar keys and upper collars.

CAUTION

Lower collars must be installed before valve guide seals. Inside diameter of lower collar is smaller than outside diameter of seal; therefore, collar will not fit over seal.

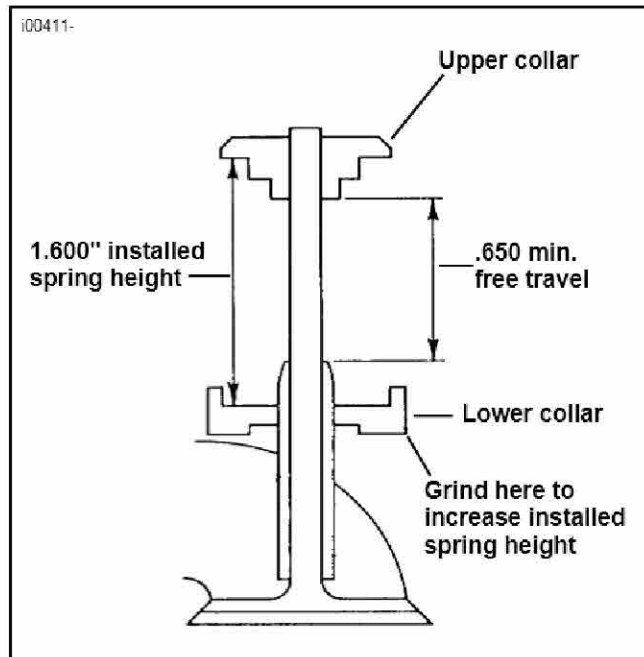

Figure 1. Check installed spring height

5. With lower collars and valves in position, place a protective sleeve over the valve stem key grooves. Coat the sleeve with oil and place a new seal over the valve stem.

CAUTION

If the seal is installed without using the protective sleeve, the seal will be damaged.

6. Tap the seal onto the guide with the valve seal installation tool included with this kit. The seal is completely installed when it gently bottoms on top of the valve guide.

CAUTION

If valves are removed after seals are installed, the sharp edges on the key groove will cut and ruin the seals.

7. Assemble cylinder heads, following Service Manual procedure, using springs, collars and keys from this kit.
8. Follow procedure in Service Manual and install heads and remaining components disassembled in Step 1.