



# INSTRUCTIONS

--J00008

REV. 7-1-95

Kit Numbers 18072-93R, 18073-93R

## TITANIUM VALVES

### General

This kit covers the installation of the following titanium valves:

18072-93R Intake  
18073-93R Exhaust

### Installation

#### I.D. of Valve Guide

Valve	Clearance	I.D. Valve Guide
Intake	0.0010 - 0.0020 in.	0.3142 - 0.3148 in.
Exhaust	0.0015 - 0.0025 in.	0.3147 - 0.3153 in.

#### NOTE

See Illustration. Clearance between retainer keys and valve stem seal at full valve lift must be 0.060 in. minimum or 0.600 in. minimum with valve on seat (see Illustration). Retainer keys protrude approximately 0.040 in. through collar. If retainer key must be shortened, trim retainer key as required. Be certain lash cap does not contact retainer keys.

#### NOTE

Double-check piston to valve clearance, compression ratio and valve spring pack.

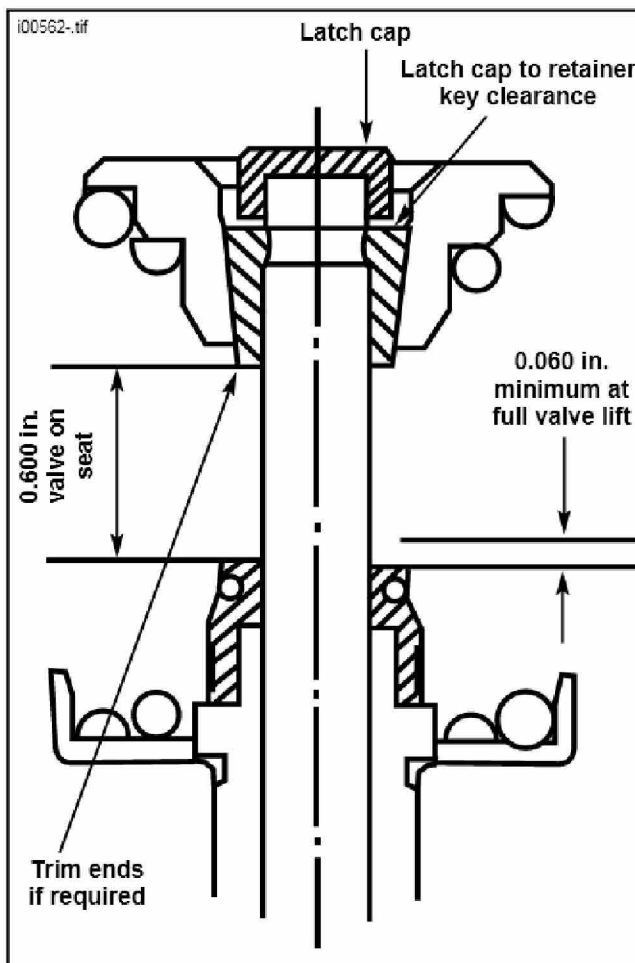

Top Collar, Spring and Seal Cross Section