



TT472: HEATED SEAT WILL NOT TURN OFF

2020-07-10



Electrical

APPLIES TO	SYMPTOMS
Heated Seat CVOs	<ul style="list-style-type: none">• Literature Updates• Heated Seat Stay On

Purpose for Technical Tip Bulletin

To inform dealers, that some 2020 Custom Vehicle Operations (CVO) models equipped with heated seats may experience the heated seat not shutting off.

Markets Affected

All markets are affected.

Issue

See Figure 1. During manufacturing, the polarity in the heated seat [191A] was reversed.

- The (R) Parts and Accessories (P&A) power wire **was** installed in [191A] terminal 4.
 - The (R) P&A power wire is **engineered** to be installed in [191A] terminal 3.
- The (BK) Ground wire **was** installed in [191A] terminal 3.
 - The (BK) Ground wire is **engineered** to be installed in [191A] terminal 4.

Resolution

The service manual supplement section "Heated Seat Diagnostics" was updated and currently viewable in Service Information Portal (SIP).

- See Figure 1. The heated seat circuit schematic graphic was updated to include the wiring between [191A] and the heated seat.
- A **new** diagnostic procedure "Heated Seat Will Not Turn Off" was added to the diagnostic procedures.

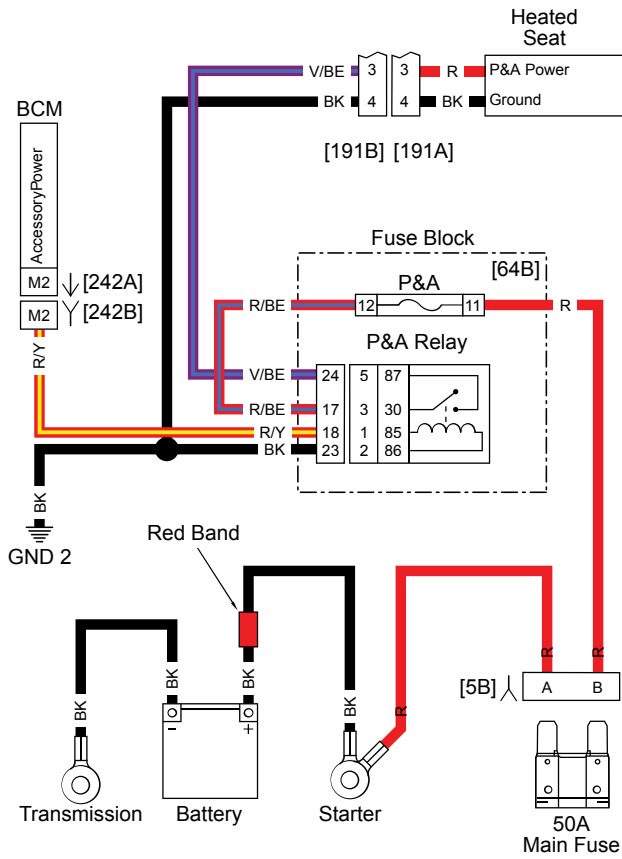

Figure 1. Heated Seat